

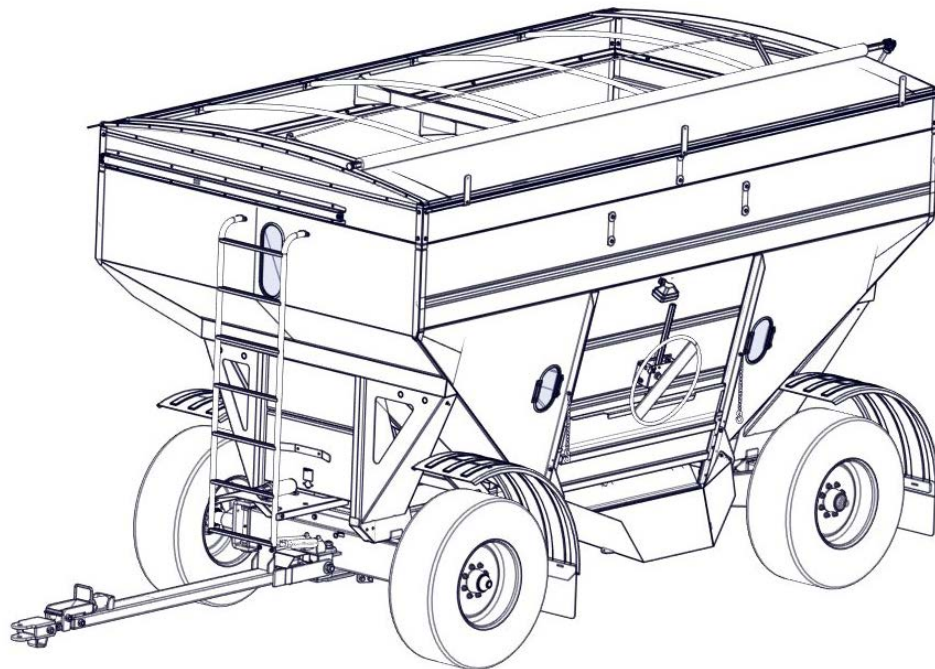

# Manual

## GRAVITY WAGON OPERATOR'S MANUAL

MODEL



Rev. 1.7.2025

J&M Manufacturing Co, Inc

284 Railroad Street - P.O. Box 547 | Fort Recovery, OH 45846 | Ph: (419) 375-2376 | Fax: (419) 375-2708

[www.jm-inc.com](http://www.jm-inc.com)



# Table Of Contents

To the Dealer .....	4
General Information .....	5
Serial Number Location .....	5
Safety Rules .....	6
Specifications and Dimensions .....	7
Decals .....	8
Bolt Torque Specifications .....	10
Initial Operation & Maintenance .....	11
Lubrication .....	12
Bleeding the Brake Lines .....	13
Fenders .....	15
Tongue Assembly with Brakes .....	16
24 Ton Running Gear .....	18
13" Brake Assembly for 24 Ton Running Gear .....	20
24 Ton Rocking Bolster .....	21
Shell Assembly .....	22
Door Wheel Assembly .....	24
Door Assembly .....	25
Roll Tarp .....	28

# To the Dealer

## TO THE DEALER

Read manual instructions and safety rules. Make sure all items on the Dealer's Pre-Delivery and Delivery Check Lists are completed before releasing equipment to the owner.

The dealer must complete the Warranty Registration found on the Dealer Portal website located at dealer.jm-inc.com and return it to J&M Mfg. Co., Inc. at the address indicated on the form. Warranty claims will be denied if the Warranty Registration has not been submitted.

### EXPRESS WARRANTY:

J&M Mfg. Co. Inc. warrants against defects in construction or materials for a period of ONE year. We reserve the right to inspect and decide whether material or construction was faulty or whether abuse or accident voids our guarantee.

Warranty service must be performed by a dealer or service center authorized by J&M Mfg. Co., Inc. to sell and/or service the type of product involved, which will use only new or remanufactured parts or components furnished by J&M Mfg. Co., Inc. Warranty service will be performed without charge to the purchaser for parts or labor based on the Warranty Labor Times schedule. Under no circumstance will allowable labor times extend beyond the maximum hours indicated in the Warranty Labor Times schedule for each warranty procedure. The purchaser will be responsible, however, for any service call and/or transportation of the product to and from the dealer or service center's place of business, for any premium charged for overtime labor requested by the purchaser, and for any service and/or maintenance not directly related to any defect covered under the warranty. Costs associated with equipment rental, product down time, or product disposal are not warrantable and will not be accepted under any circumstance.

Each warranty term begins on the date of product delivery to the purchaser. Under no circumstance will warranty be approved unless (i) the product warranty registration card has been properly completed and submitted to the equipment manufacturer, and (ii) a warranty authorization number has been issued by the equipment manufacturer. This Warranty is effective only if the warranty registration card is returned within 30 days of purchase.

This warranty does not cover a component which fails, malfunctions or is damaged as a result of (i) improper modification or repair, (ii) accident, abuse or improper use, (iii) improper or insufficient maintenance, or (iv) normal wear or tear. This warranty does not cover products that are previously owned and extends solely to the original purchaser of the product. Should the original purchaser sell or otherwise transfer this product to a third party, this warranty does not transfer to the third party purchaser in any way. J&M Mfg. Co., Inc. makes no Warranty, express or implied, with respect to tires or other parts or accessories not manufactured by J&M Mfg. Co., Inc. Warranties for these items, if any, are provided separately by their respective manufacturers.

THIS WARRANTY IS EXPRESSLY IN LIEU OF ALL OTHER WARRANTIES OR CONDITIONS, EXPRESS, IMPLIED OR STATUTORY, INCLUDING ANY IMPLIED WARRANTY OF MERCHANTABILITY OR FITNESS FOR PARTICULAR PURPOSE.

In no event shall J&M Mfg. Co., Inc. be liable for special, direct, incidental or consequential damages of any kind. The exclusive remedy under this Warranty shall be repair or replacement of the defective component at J&M Mfg. Co., Inc.'s option. This is the entire agreement between J&M Mfg. Co., Inc. and the Owner about warranty and no J&M Mfg. Co., Inc. employee or dealer is authorized to make any additional warranty on behalf of J&M Mfg. Co., Inc.

The manufacturer reserves the right to make product design and material changes at any time without notice. They shall not incur any obligation or liability to incorporate such changes and improvements in products previously sold to any customer, nor shall they be obligated or liable for the replacement of previously sold products with products or parts incorporating such changes.

### SERVICE:

The equipment you have purchased has been carefully manufactured to provide dependable and satisfactory use. Like all mechanical products, it will require cleaning and maintenance. Lubricate the unit as specified. Observe all safety information in this manual and safety signs on the equipment.

For service, your authorized J&M dealer has trained mechanics, genuine J&M service parts, and the necessary tools and equipment to handle all your needs.

Use only genuine J&M service parts. Substitute parts may void warranty and may not meet standards required for safety and satisfactory operation. Record the model number and serial number of your equipment in the spaces provided:

**Model No:** 655/755 Gravity Wagon **Serial No:** \_\_\_\_\_ **Date of Purchase:** \_\_\_\_\_

**Purchased From:** \_\_\_\_\_

Provide this information to your dealer to obtain correct repair parts.



# General Information

## TO THE OWNER:

The purpose of this manual is to assist you in operating and maintaining your gravity wagon in a safe manner. Read it carefully. It furnishes information and instructions that will help you achieve years of dependable performance and help maintain safe operating conditions. If this machine is used by an employee or is loaned or rented, make certain that the operator(s), prior to operating:

1. Is instructed in safe and proper use.
2. Reviews and understands the manual(s) pertaining to this machine.

Throughout this manual, the term **IMPORTANT** is used to indicate that failure to observe can cause damage to equipment. The terms **CAUTION**, **WARNING** and **DANGER** are used in conjunction with the Safety-Alert Symbol, (a triangle with an exclamation mark), to indicate the degree of hazard for items of personal safety. When you see this symbol, carefully read the message that follows and be alert to the possibility of personal injury or death.



This Safety-Alert symbol indicates a hazard and means **ATTENTION! BECOME ALERT! YOUR SAFETY IS INVOLVED!**



**DANGER**

Indicates an imminently hazardous situation that, if not avoided, will result in death or serious injury.



**WARNING**

Indicates a potentially hazardous situation that, if not avoided, could result in death or serious injury, and includes hazards that are exposed when guards are removed.



**CAUTION**

Indicates a potentially hazardous situation that, if not avoided, may result in minor or moderate injury.

**IMPORTANT**

Indicates that failure to observe can cause damage to equipment.

**NOTE**

Indicates helpful information.

# Serial Number Location

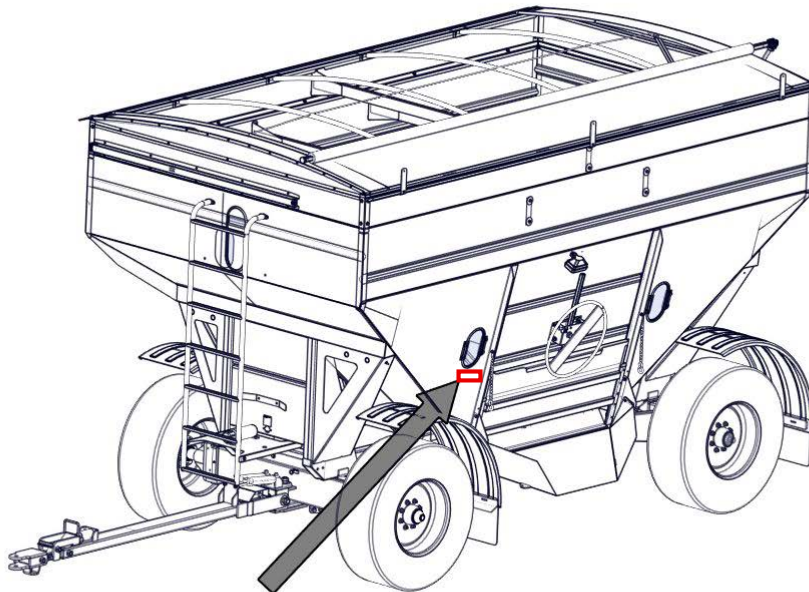

**Serial Number Location**

Serial Number: \_\_\_\_\_

Model Number: 655/755 Gravity Wagon

Standard practice when ordering parts or obtaining information from your dealer requires the serial number and model number. Have numbers available before making contact.

# Safety Rules

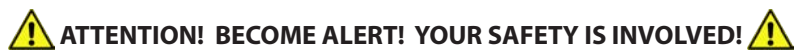

Safety is a primary concern in the design and manufacture of our products. Unfortunately, our efforts to provide safe equipment can be erased by an operator's single careless act. In addition, hazard control and accident prevention are dependent upon the awareness, concern, judgment, and proper training of personnel involved in the operation, transport, maintenance and storage of equipment.

Make certain that the operator(s), prior to operating is instructed in safe and proper use and reviews and understands the manual(s) pertaining to this machine. Also make certain that the operator(s) reviews and understands the operator's manual of the tow vehicle prior to hooking up or operating the gravity wagon.

Read this manual before you operate this machine. If you do not understand any part of this manual, or need more information, contact the manufacturer or your authorized dealer. **COMPLY WITH ALL SAFETY WARNINGS AND CAUTIONS IN THIS MANUAL AND IN THE COMBINE OPERATOR'S MANUAL**

1. Understand that your safety and the safety of other persons are measured by how you service and operate this machine. Know the positions and functions of all controls before you try to operate them. Check all controls in a safe area before starting your work.
2. The safety information given in this manual does not replace safety codes, federal, state, or local laws. Ensure your machine has the proper equipment as designated by local laws and regulations.
3. A frequent cause of personal injury or death is from persons falling off equipment and being run over. Do not permit persons to ride on this machine.
4. Travel speeds should be such that complete control and machine stability is maintained at all times. Where possible, avoid operating near ditches, embankments and holes. Reduce speed when turning, crossing slopes and rough, slick or muddy surfaces.
5. Collision of high speed road traffic and slow moving machines can cause personal injury or death. On roads, use flasher lights according to local laws. Keep slow-moving-vehicle emblem visible. Pull over to let faster traffic pass.
6. Fasten the gravity wagon securely to the pulling vehicle using the proper hitch pin, clip, and safety chains.
7. Before unhooking the implement from the towing unit, be sure to properly block the wheels to prevent the implement from moving.
8. Never overload the wagon. Overloading the wagon is dangerous and can cause extensive damage. Never add more sideboards to the gravity box than what is recommended, as the box is not designed to carry the additional weight. Do NOT exceed speeds in excess of 20 MPH. Rims, hubs and bearings are designed for heavy loads at slow speeds. Also ensure slow moving vehicle emblem is attached to the rear of the wagon.
9. **IMPORTANT:** Use caution when transporting. Be alert of the transport unit's overall width when approaching obstacles, such as post signs and poles, along the road. Check the transport width of the unit to ensure clearance before entering bridges.
10. Do not allow anyone to stand between tongue or hitch and towing vehicle when backing up.
11. Choose the most level route possible when transporting across fields.
12. Never adjust, service, clean, or lubricate gravity wagon until all power is shut off.
13. Keep all safety shields in place. Keep hands, feet, hair, and clothing away from the moving parts while the unit is in operation.
14. The service ladder is for service work only. If you must climb into the grain tank, be certain all power is off and use extreme caution. Never allow anyone in, near or on the gravity box during transporting or unloading grain. Moving grain is dangerous and can cause entrapment, resulting in severe injury or death by suffocation.
15. Make sure that everyone is clear of equipment before applying power or moving the machine.
16. **WARNING: BE SURE ALL LIGHTS ARE WORKING PROPERLY BEFORE HIGHWAY TRAVEL.**



# Specifications and Dimensions

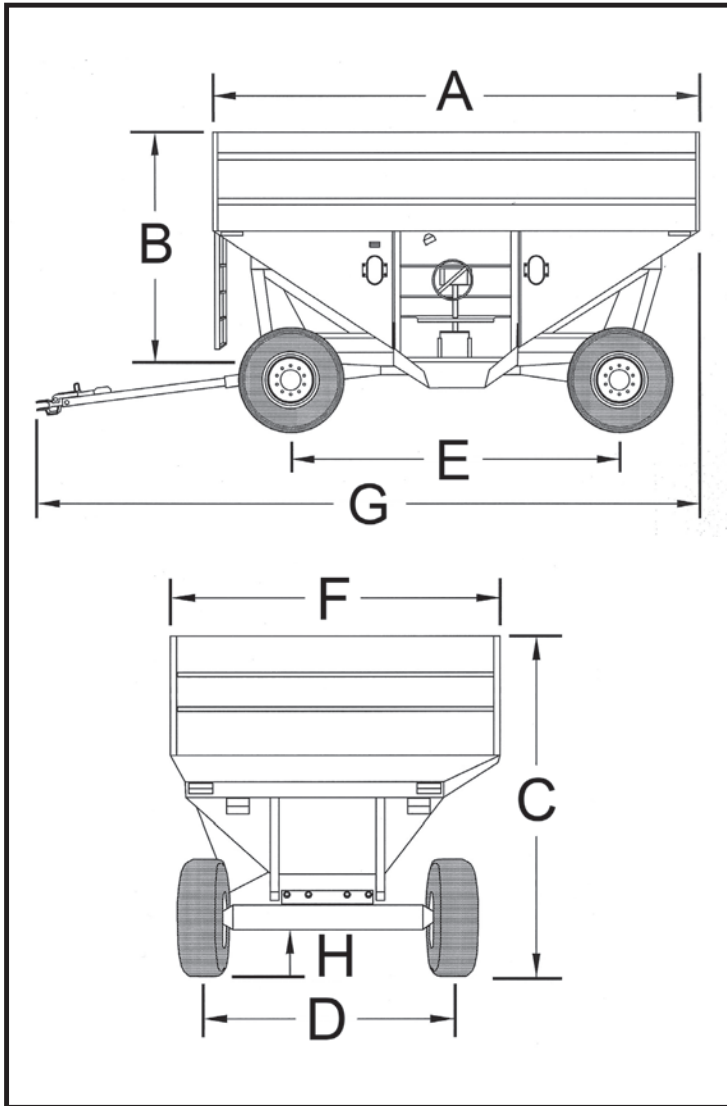

	655	755
A	17'-7"	17'-7"
B	7'-11"	8'-7"
C	10'-5"	11'-2"
D	7'-8"	7'-8"
E	11'-5"	11'-5"
F	9'-6"	9'-6"
G	25'-4"	25'-4"
H	1'-5"	1'-5"

	655	755
Capacity - Box	660 Bushels	760 Bushels
Door Width	60"	60"
Chute Height	Adjustable 14"-19"	Adjustable 14"-19"
Hopper Steel	12 & 9 Gauge	12 & 9 Gauge
Understructure	3" x 6" Runners	3" x 6" Runners
Taillights	Standard	Standard
Front Ladder	Standard	Standard
Center Dump Deflector	Optional	Optional
Capacity - Running Gear	24 Tons	24 Tons
Spindles	3-3/8" Diameter	3-3/8" Diameter
Wheels	22.5 x 13 - 10 Bolt	22.5 x 13 - 10 Bolt
Tires	16-22.5 or 18-22.5	16-22.5 or 18-22.5
Hydraulic Brakes	Optional 4-Wheel Drum	Optional 4-Wheel Drum
Weight	6,800 lbs	7,050 lbs

# Decals

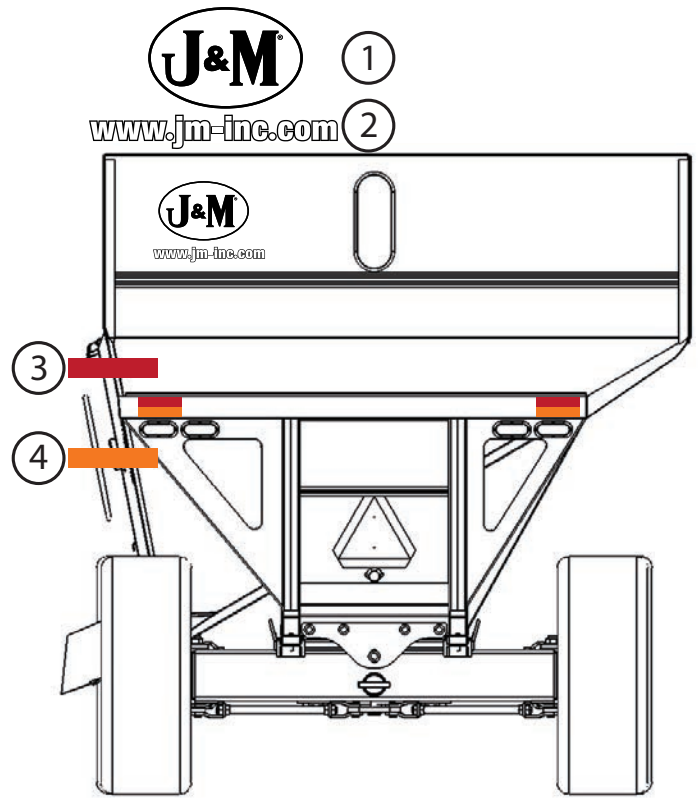
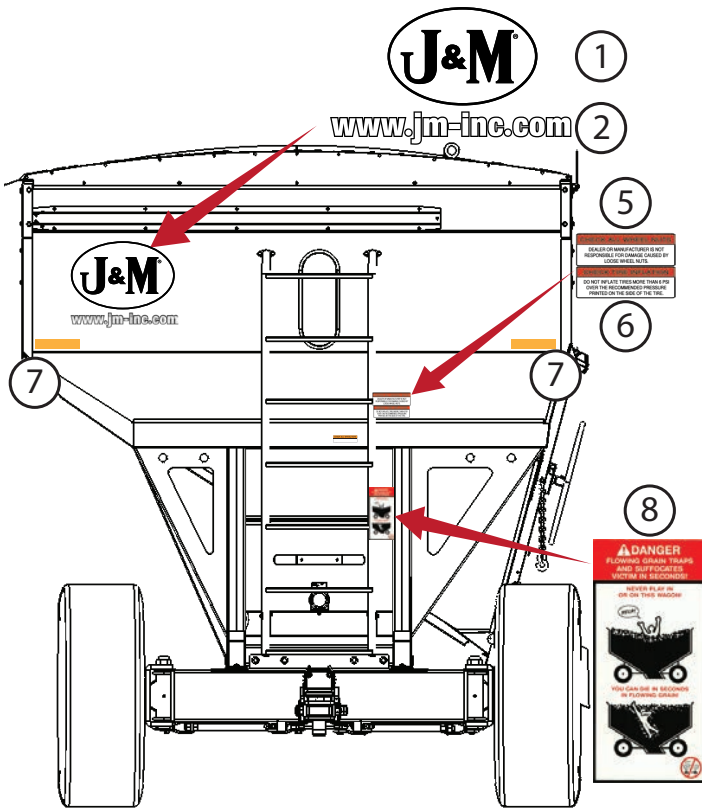

Description	Part No.
1 J&M Oval Decal (Large) 9-1/2" x 15"	JM0015151
2 www.jm-inc.com Decal	JM0019239
3 Red Reflective Decal 2" x 9"	JM0009945
4 Orange Reflective Decal 2" x 9"	JM0009944
5 Check All Wheel Nuts Decal	JM0018043
6 Check Tire Inflation Decal	JM0018041
7 Amber Reflective Decal 2" x 9"	JM0009946
8 Danger, Flowing Grain Traps GW Decal	JM0019223
9 655 Driver's Side Decal	JM0036548
9 755 Driver's Side Decal	JM0036554
10 For Farm Use Only Decal	JM0018038
11 Caution, Fasten Box Securely Decal	JM0019228
12 Door Light Decal (Gravity Wagon)	JM0036562
13 Warning, Keep Lug Nuts Tightened Decal	JM0024420
14 J&M Oval Decal (Medium) 5-1/2" x 8-1/2"	JM0010179
15 655 Passenger's Side Decal	JM0036549
15 755 Passenger's Side Decal	JM0036553
16 Caution, Keep Lug Nuts and Lug Bolts Tightened Decal	JM0019220
17 Caution, Check Fluid Level in Master Cylinder Decal	JM0019229



# Decals

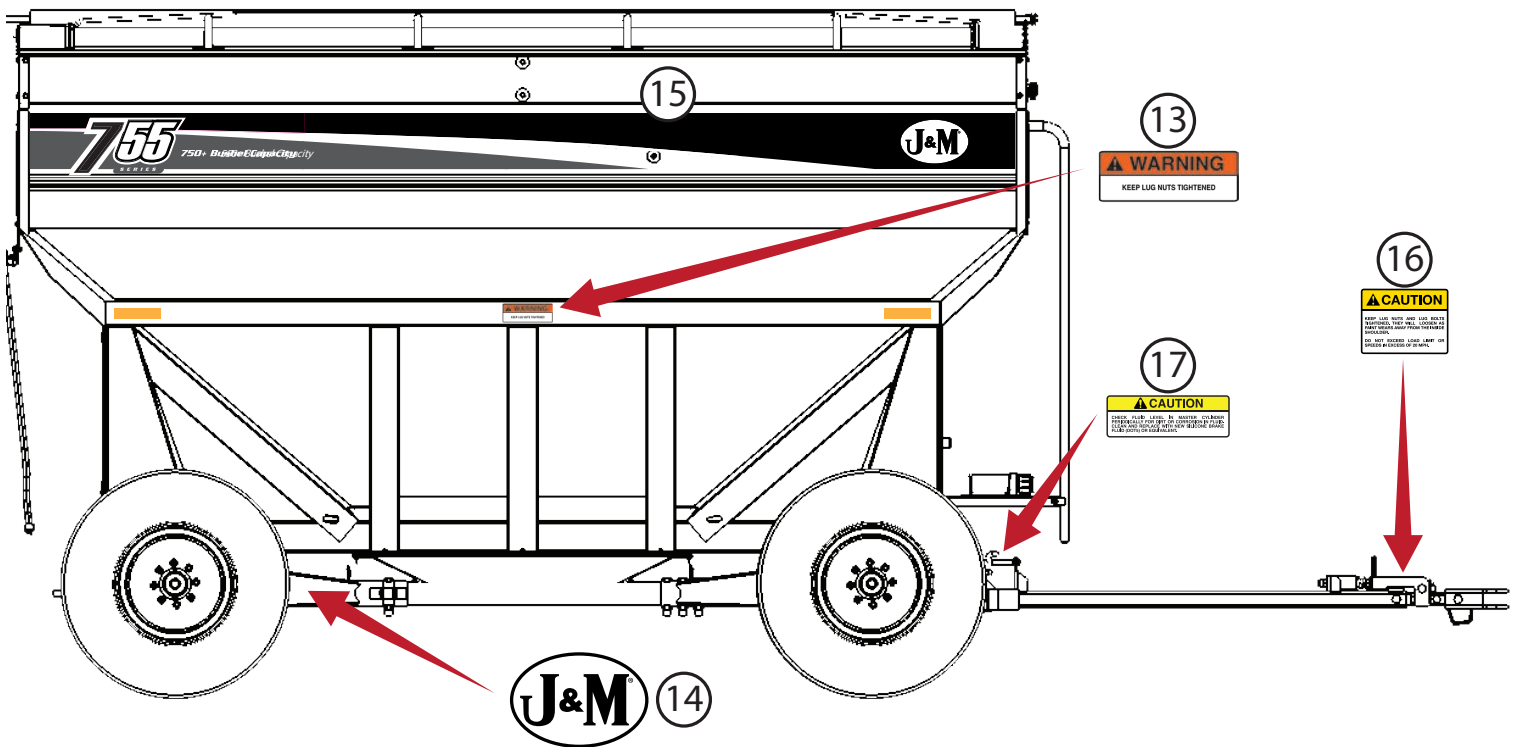
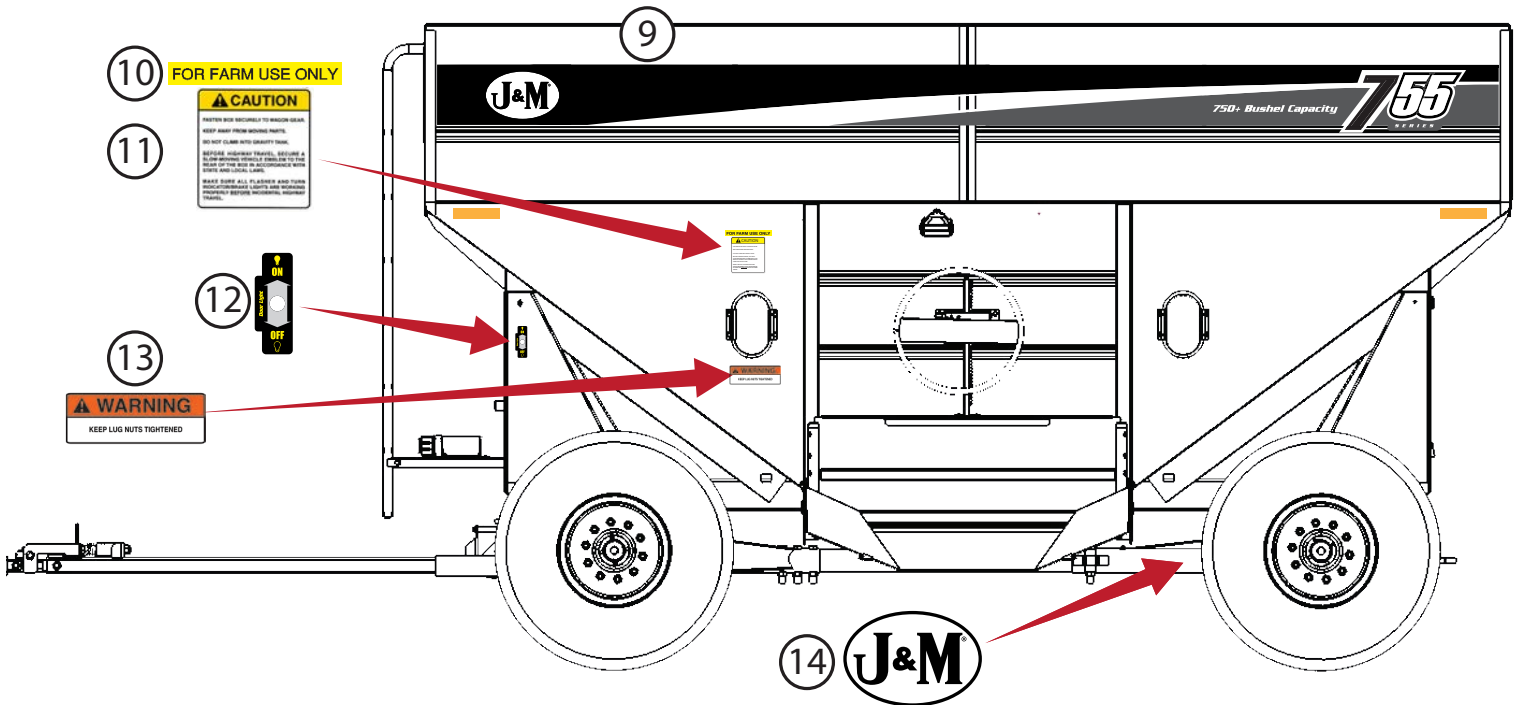

# Bolt Torque Specifications

Always tighten hardware to these values unless a different torque or tightening procedure is listed for specific application. Fasteners must always be replaced with the same grade as specified in the manual parts list. Always use the proper tool for tightening hardware. Make sure fastener threads are clean and you start thread engagement properly. **Use these values when tightening all bolts and nuts with the exception of wheel nuts.**

## SAE Fasteners

Coarse Thread Series				
Diameter and Pitch (Inches)	Grade 5		Grade 8	
	Dry	Oiled	Dry	Oiled
1/4"-20	8 ft-lbs	6 ft-lbs	12 ft-lbs	9 ft-lbs
5/16"-18	17	13	25	18
3/8"-16	31	23	44	33
7/16"-14	49	37	70	52
1/2"-13	75	57	106	80
9/16"-12	109	82	154	115
5/8"-11	150	113	212	159
3/4"-10	267	200	376	282
7/8"-9	429	322	606	455
1"-8	644	483	909	681
Fine Thread Series				
Diameter and Pitch (Inches)	Dry	Oiled	Dry	Oiled
1/4"-28	10 ft-lbs	7 ft-lbs	14 ft-lbs	10 ft-lbs
5/16"-24	19	15	27	20
3/8"-24	35	26	49	37
7/16"-20	55	41	78	58
1/2"-20	85	64	120	90
9/16"-18	121	91	171	128
5/8"-18	170	127	240	180
3/4"-16	297	223	420	315
7/8"-14	474	355	669	502

## Stud and Wheel Nut Torque Specifications

Always tighten hardware to these values unless a different torque or tightening procedure is listed for specific application. Fasteners must always be replaced with the same grade as specified in the manual parts list. Always use the proper tool for tightening hardware. Make sure fastener threads are clean and you start thread engagement properly. **Use these values when tightening all studs and wheel nuts.**

Stud	Tightening Torque
1/2"-20	120 ft-lbs
9/16"-18	170 ft-lbs
5/8"-18	300 ft-lbs
3/4"-16	400 ft-lbs
20mm	475 ft-lbs
22mm	640 ft-lbs

**TIGHTENING WHEEL NUTS:** Torque 3/4"-16 lug nuts on wheels to 400 ft-lbs after the first 10, 25, and 50 miles of driving, then recheck torque every 50 hours or every year, whichever comes first. Failure to do so may damage wheel nut seats. Once seats are damaged it will become impossible to keep nuts tight.

# Initial Operation & Maintenance

## ***Initial Operation***

 **WARNING: Ensure all power is shut off before servicing the gravity wagon.**

Before the gravity wagon is put into service, check the following items for safe operation:

- The track assembly for the door has proper lubrication for less wear on the sprocket and track and easier door operation.
- The SMV (Slow Moving Vehicle) sign is positioned with a point of the triangle upward and as near to the rear and centered or as near to the left of center of the unit as practicable. The lower edge of the sign should be located 2-10 feet above the ground.
- The gravity wagon is properly attached to the running gear. If no rocking bolster is used, bolt all four corners (use 1/2" bolts provided) of the gravity wagon runners to the running gear. (If the box is used in rough terrain, bolt a minimum of two corners and chain (or cable) the remaining corners to allow more box flexibility.)
- Check all braces, bolts, nuts, lug bolts, and lug nuts been checked to ensure they are properly fastened. **The proper torque for the wheel lug nuts is 350 ft lbs.**
- All operators of this machine have read and clearly understand the safety instructions.
- All lights must work properly. All reflective decals are clean, visible, and positioned correctly.
- Tires are properly inflated. The following is to be used as a **general guide** for tire inflation for cyclic use. Figures can vary depending on specific brand of tire used. **It is important that tires are inspected before and after the unit is loaded. The tire should stand up with no side wall buckling or distress as the tire rolls. Do not exceed the tire pressure indicated below:**

Tire Size	psi
425/65R22.5	85
445/65R22.5	85

 **WARNING: Tow loads safely**

Stopping distance increases with speed and weight of towed loads, and on slopes. Towed loads with or without brakes that are too heavy for the tractor or are too fast can cause loss of control. Consider the total weight of the equipment and its load.

**For towed equipment WITHOUT brakes, the following is recommended:**

Do NOT tow equipment that does not have brakes at speeds over 32 km/h (20 mph); or that, when fully loaded, has a mass (weight) over 1.5t (3300 lb) and more than 1.5 times the mass (weight) of the towing unit.

**For towed equipment WITH brakes, the following is recommended:**

Do NOT tow equipment that has brakes at speeds over 40 km/h (25 mph); or that, when fully loaded, has a mass (weight) more than 4.5 times the mass (weight) of the towing unit.

Ensure the load does not exceed the recommended weight ratio. Use additional caution when towing loads under adverse conditions, when turning and on inclines.

 **WARNING: Before filling the gravity wagon, make certain that no one is inside the grain tank. Never allow children or anyone in, near, or on the gravity wagon during transport or during loading or unloading of grain. Be aware that moving grain is dangerous and can cause entrapment, resulting in severe injury or death by suffocation.**

After hauling corrosive materials such as fertilizers, be sure to wash out the grain tank to prevent premature rusting. Bare spots on metal should be primer coated before applying the outer surface paint.

Check the box periodically for cracks in welds and for other structural damage. Have cracked welds fixed immediately. Failure to do so could result in extensive damage and greatly reduce the life of the gravity wagon.

# Lubrication

**Your gravity wagon has grease fittings at all critical points. These should be serviced before the gravity wagon is put into operation each season.**

When changing the oil after the first year, recheck the castle nut tightness. The hub components can loosen after initial break in period. Retightening the castle nut will prevent too much endplay in subsequent years; they do not tend to loosen after retightening. If bearing components are ever replaced the castle nut should be retightened the following year.

## HOW TO FLUSH OLD OIL OUT OF THE OIL BATH HUBS

Your gravity wagon is equipped oil bath hubs. Follow these steps to flush the oil bath hubs once per year.

1. Check the hub for leaks and wear. Replace components as necessary.
2. Roll the hub until the fill plug is on top.
3. Drain the hub by removing the cap.
4. After draining the old oil, use light weight motor oil to flush out remaining oil. There is no need to tilt the hub, the oil will flow through the bearing easily.
5. Replace cap. Torque cap to 30-40 ft-lbs.
6. Replace oil with 80-90WT Sta-Lube from NAPA. This oil has a rust inhibitor additive.

## HOW TO ADD OIL TO OIL BATH HUBS

**IMPORTANT: Use Napa STA-Lube - GL5 80/90 WT with Rust Inhibitors FL2472 for the Oil Bath Hubs.**

1. Use a 3/4" wrench to remove breather plug.
2. Add 80-90WT Sta-Lube oil from NAPA with an oiler hand pump. **The recommended oil capacity in the hubs is 8 ounces.**
3. Replace breather plug. First hand tighten, then use 3/4" wrench to make a 1/4" of a turn.

# Routine Maintenance

 **WARNING: Ensure all power is shut off before servicing the gravity wagon.**

- Check the gravity wagon periodically for cracks in welds and for other structural damage. Fix cracked welds immediately. Failure to do so could result in extensive damage to the gravity wagon and greatly reduce the life of the unit.
- If equipped with uni-swivel auger, check all hydraulic hoses for wear and replace as necessary.
- Ensure all tires are properly inflated. Refer to "Initial Operation & Maintenance" on page 11 for recommended tire pressures. It is important that tires are inspected before and after unit loaded.
- Ensure all grease fittings have proper lubrication.
- Properly torque all lug nuts to 350 ft-lbs.

Your local, authorized dealer can supply genuine replacement parts. Substitute parts not provided by J&M Manufacturing may not meet original equipment specifications and may be dangerous.

When performing maintenance work, wear sturdy, rough-soled work shoes and protective equipment for eyes, hair, hands, hearing and head. Follow instructions in this manual to ensure safe and proper maintenance and repair.

# Storage Preparation

Store the gravity wagon in a dry, protected place. Leaving your gravity wagon outside, open to the weather will shorten its life.

Follow the procedure below when your gravity wagon is placed in storage for periods up to six months:

1. Remove all grain from inside the grain tank.
2. Wash or clean and completely lubricate the gravity wagon.
3. Touch up areas where paint may have worn away. Use a good quality primer paint, especially before re-applying graphite paint to the interior slopes of the grain tank.
4. Clean the tires before storage. Inflate the tires at regular intervals.

# Bleeding the Brake Lines

## METHOD ONE (requires two people)

1. Close all bleed screws
2. Start with the wheel furthest from the master cylinder. Slip a transparent bleed hose on the bleeder stem and place the other end of the hose in a clean container which is partially filled with fluid at all times.
3. The first person depresses the brake plunger SLOWLY. This should take 3-5 seconds. Next, the second person opens the bleed screw. He then closes the bleed screw BEFORE the first person SLOWLY releases the plunger. This should again take 3-5 seconds. Continue process until there is no evidence of air in the bleed hose.
4. Repeat for remaining wheels working from the longest to the shortest distance from the master cylinder. Top off master cylinder as needed to prevent reintroducing air into the lines.

## METHOD TWO (one person)

1. Attach bleed hose to rear wheel as in method one. Open bleed screw. SLOWLY depress plunger (3-5 seconds). Repeat until line is air free. Close bleed screw. Top off master cylinder as needed to prevent reintroducing air into the lines.
2. Repeat with remaining wheels.

**⚠ DANGER: Contamination with dirt, water, petroleum products or other materials may result in brake failure or costly repairs.**

# Adjusting the Brake Master Cylinder

1. Use a 9/16" wrench to remove the (2) 3/8" x 1" serrated hex head bolts and shield.
2. Loosen the 1/2" nut on the plunger pin. Use a 3/4" wrench.
3. Rotate the plunger rod to adjust. The braking plunger system should have approximately a 1/4" of play when adjusted for level road travel. For more aggressive braking action turn the plunger rod counterclockwise. This will lengthen the assembly. For less aggressive braking action turn the plunger rod clockwise. This will shorten the assembly.

**DANGER: Do not adjust all the play out of the plunger system. This will cause the brakes to be activated at all times and overheat the drums, causing failure.**

**NOTE: This braking system is designed to assist the pull vehicle in braking, not to take the place of it.**

4. Tighten the 1/2" hex nut to keep plunger rod in place.
5. Put the shield back on and tighten both 3/8" x 1" SF hex bolts.

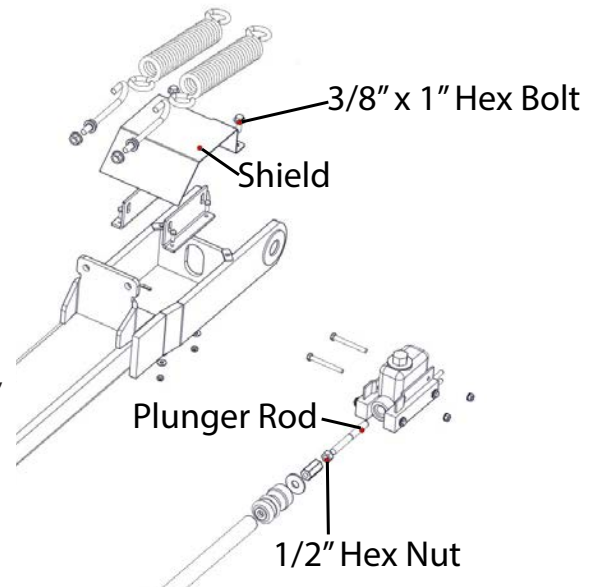

# Adjusting the Brakes

The brake adjustment nut is located behind a slot at the bottom of the backing plate. Tighten the nut until you cannot rotate the wheel by hand, then back off the adjustment 18 to 20 notches.

**IMPORTANT:** When adjusting drum brakes, rotate the wheel and drum in a forward rotation only.

# Gravity Wagon Trail Adjustment

- Ensure the tongue bolt is as tight as possible without over restricting the vertical motion of the hitch.
- An extra washer (shown below) can be added if the nut is tightened so far that it runs out of threads before the tongue bolt is as tight as possible.

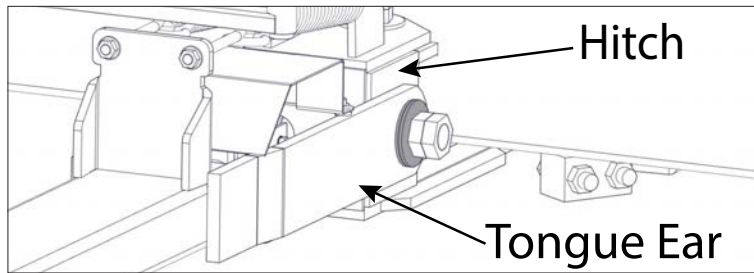

- Ensure all tires are properly inflated. Refer to "Initial Operation & Maintenance" on page 11 for recommended tire pressures.
- If either of the front tires look to be excessively worn or unevenly worn they should be rotated with a less worn rear tire, if possible.
- Toe the front tires inward 3/16" on front from rim to rim (acceptable range for tired to be toed inward is 1/8" to 1/4"). For directions on how to adjust the toe-in, follow the steps below.
- Ensure the inner tongue bolt (shown below) is tightened enough to mitigate slop but still allow the inner tongue to slide in and out of the outer tongue. It is acceptable to see the outer tongue squeezed inward by the inner tongue bolt for a slop-free fit.

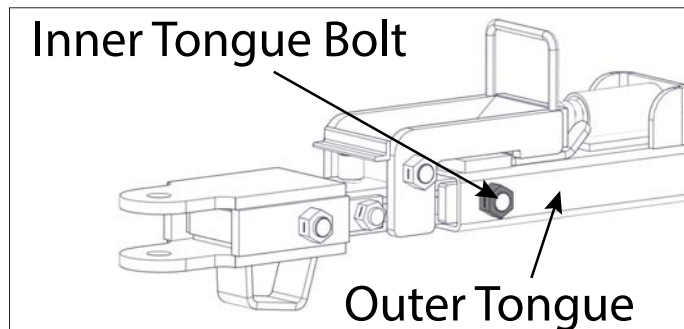

# Adjusting Running Gear Toe-In

1. Position the tongue in the straight and horizontal position. Measure both "L1" locations. Once both locations are the same length, move to the next step.
2. Measure both "L2" locations. Adjust both tie-rods to ensure both measurements are equal.
3. Measure "L3" and "L4" distances. L3 should be set 3/16" smaller than L4 by adjusting the tie-rods in equal amounts.
4. Measure both "L2" locations again to ensure they are the same. If L2 lengths are different, repeat the process.

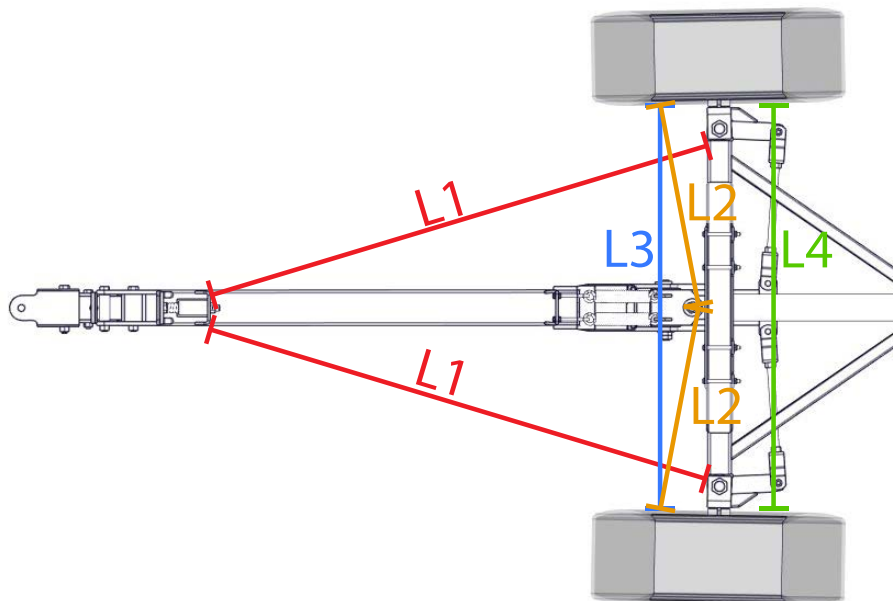

# Fenders

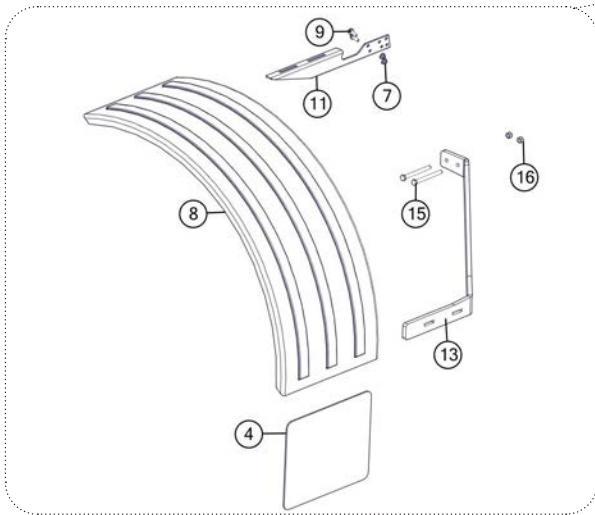
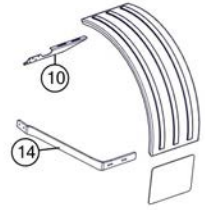
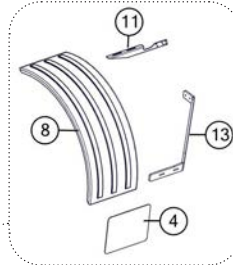
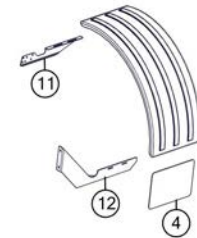
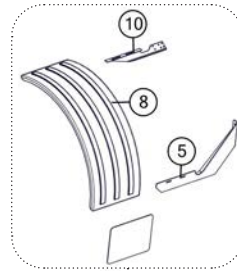
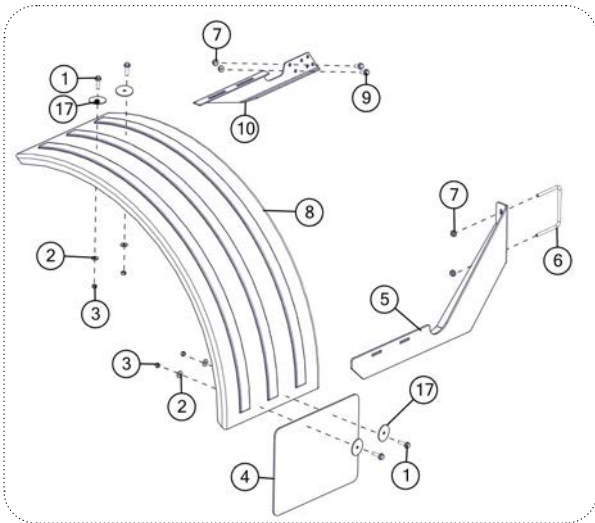

Description	Part No.
1 3/8"-16 x 1-1/2" Gr5 Z SF Hex Bolt	JM0001633
2 3/8" USS Flat Washer	JM0003061
3 3/8"-16 Gr2 Z Centerlock Hex Nut	JM0001512
4 55 Series Mud Flap	JM0033494
5 Front Lower Left Fender Bracket (655, 755)	JM0034359
6 3/8"-16 x 6" x 4-5/8" Square U-Bolt	JM0033399
7 3/8"-16 Gr5 Z SF Hex Nut	JM0002152
8 Fender (55 Series)	JM0033393
9 3/8"-16 x 1" Gr5 Z SF Hex Bolt	JM0002092
10 Front Upper Left Fender Bracket (55 Series)	JM0033395
11 Front Upper Right Fender Bracket (55 Series)	JM0033435
12 Front Lower Right Fender Bracket (655, 755)	JM0034362
13 Rear Lower Left Fender Bracket (655, 755)	JM0034376
14 Rear Lower Right Fender Bracket (655, 755)	JM0034372
15 1/2"-13 x 5-1/2" Gr5 Z Hex Bolt	JM0001498
16 1/2"-13 Gr2 Z Centerlock Hex Nut	JM0001511
17 7/16" ID x 2-1/2" OD x 1/8" Z USS Flat Washer	JM0018982

# Wheels and Tires

Description	Part No.
1 Wheel Rim, 10 hole, 22.5" x 13" (WR-22.5-13)	JM0029569
2 425/65R22.5 (Used) Tire Mounted on 22.5" x 13", 10 Bolt Wheel	JM0029567
2 Wheel & Tire 445-65R22-1/2 Mounted on 22-1/2 x 13, 10 Bolt	JM0034965
2 VF445/65R22.5 174D Tire Mounted on 22.5" x 13", 10 Bolt Wheel	JM0084951

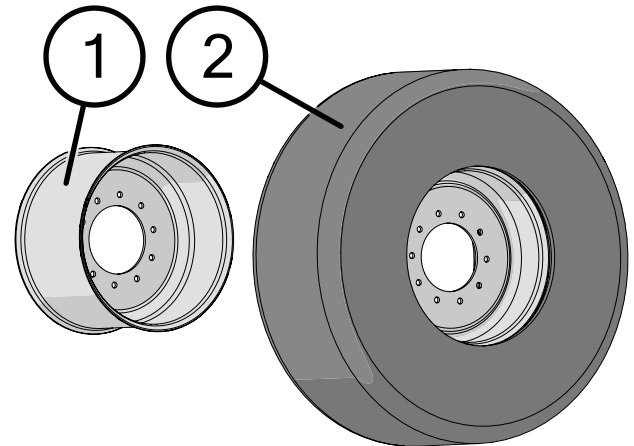

# Tongue Assembly with Brakes

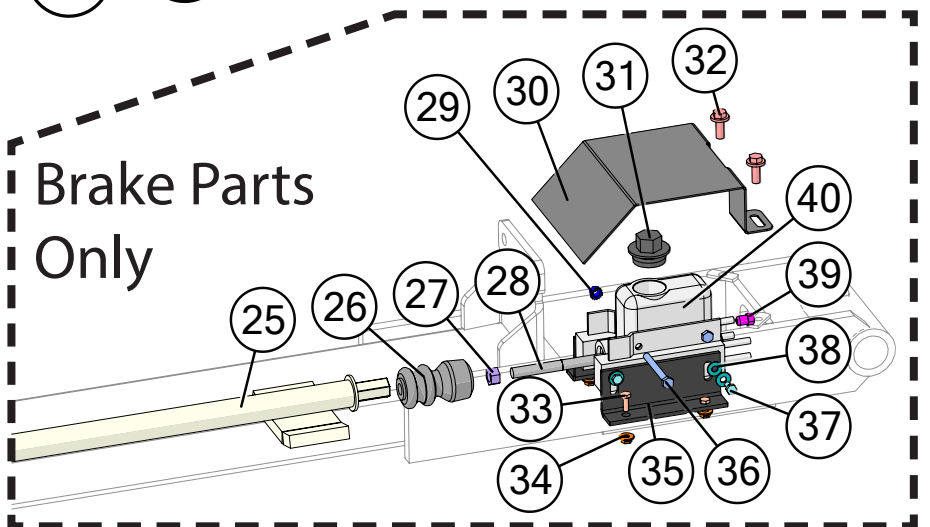
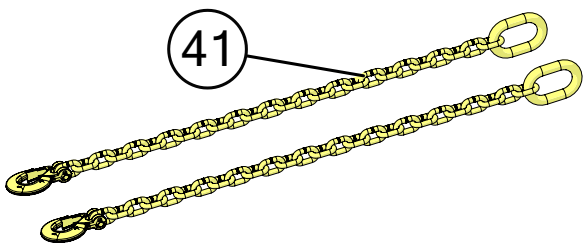
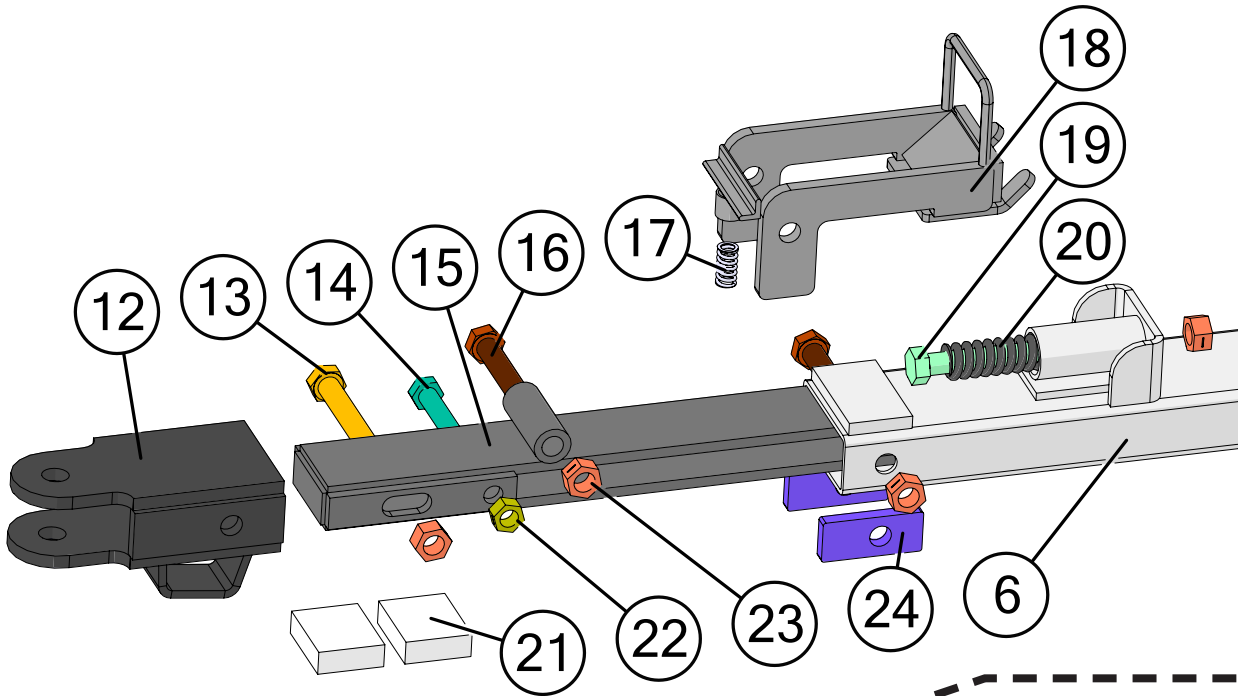
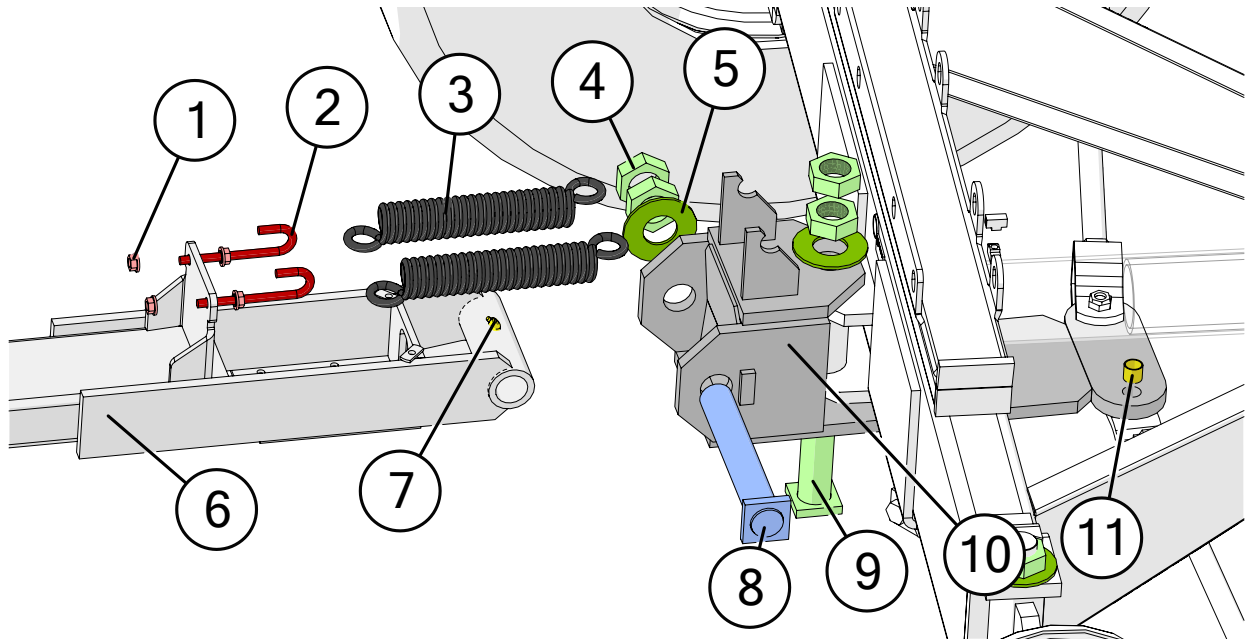



# Tongue Assembly with Brakes

	Description	Part No.
1	1/2"-13 Gr5 Z SF Hex Nut	JM0002153
2	1/2"-13 x 6" Gr5 Z J-Bolt	JM0002168
3	Tongue Extension Spring - 55 Series Gravity Box	JM0038587
4	1-3/4"-12 Z Gr2 Hex Jam Nut	JM0009752
5	1-3/4" USS Flat Washer	JM0029723
6	24 Ton Outer Tongue Cushion Hitch Assembly (55 Series)	JM0029536
7	45 Degree Grease Zerk - 1/8" NPT	JM0029555
8	Tongue Bolt (1 1/4" x 10 1/4") 12-15 Ton (TB-1215)	JM0029378
9	1-3/4" x 11-3/4" King Pin Vertical Hitch Bolt	JM0029375
10	Hitch Weldment, 24 Ton Running Gear	JM0029107
11	7/8" ID x 1" OD x 7/8" LG Bronze Bushing (BB-78)	JM0029185
12	Front of Cushion Hitch (55 Series Running Gear)	JM0032324
13	1"-8 x 7-1/2" Gr8 YZ Hex Bolt	JM0017944
14	7/8"-9 x 6" Gr8 Z Hex Bolt	JM0032815
15	Tongue Hitch Insert (55 Series)	JM0033959
16	1"-8 x 7" Gr5 Z Hex Bolt	JM0016689
17	Compression Spring (1" x 1-3/4") for Door Assembly & Tongue Latch	JM0001688
18	Tongue Latch for Gravity Wagon (TL-1324)	JM0019289
19	1"-8 x 9" Gr8 Z Hex Bolt	JM0001708
20	3/8" Wire x 1-5/16" Diameter x 7" Long Compression Spring (CM1516112)	JM0019293
21	Rubber Bar for Running Gear Inner Tongue (3-15/16" x 3-1/8" x 1-1/4")	JM0032331
22	7/8"-9 Gr2 Z Centerlock Hex Nut	JM0002148
23	1"-8 Gr2 Z Centerlock Hex Nut	JM0002149
24	Brake Limiter on Gravity Wagon (BL-58) 5/8"x2"x4-3/4"	JM0019306
25	51-1/8" Long Plunger Pole (655/755)	JM0035044
26	Rubber Boot on Master Cylinder (RB-1415)	JM0019358
27	1/2"-13 Gr2 Z Hex Nut	JM0002124
28	Master Cylinder Plunger Rod End (PRE-1)	JM0019341
29	5/16"-18 Gr5 Z Star Washer Hex Nut	JM0019361
30	Shield for Master Cylinder (SMC-1)	JM0019273
31	Master Cylinder Cap (RCMC-1324)	JM0019357
32	3/8"-16 x 1" Gr5 Z SF Hex Bolt	JM0002092
33	1/4"-20 x 3/4" Gr5 Z Hex Bolt	JM0001507
34	1/4"-20 Gr5 Z SF Hex Nut	JM0001630
35	Mounting Bracket with Springs for Master Cylinder (2 Pieces) (MBMC-DR2)	JM0019340
36	5/16"-18 x 3" Gr5 Z Hex Bolt	JM0019359
37	1/4"-20 x 1/2" Gr5 Z Hex Bolt	JM0001481
38	1/4" ID, 3/4" OD Z Flat Washer	JM0003090
39	1/64" Orifice Restrictor Fitting for Drum Brake Master Cylinder	JM0027857
40	Master Cylinder with Spring Bracket (MCA-DR1)	JM0019356
40	Seal Kit for Master Cylinder (SKMC-1324)	JM0036060
41	30k Lb Safety Chain	JM0031890

# 24 Ton Running Gear

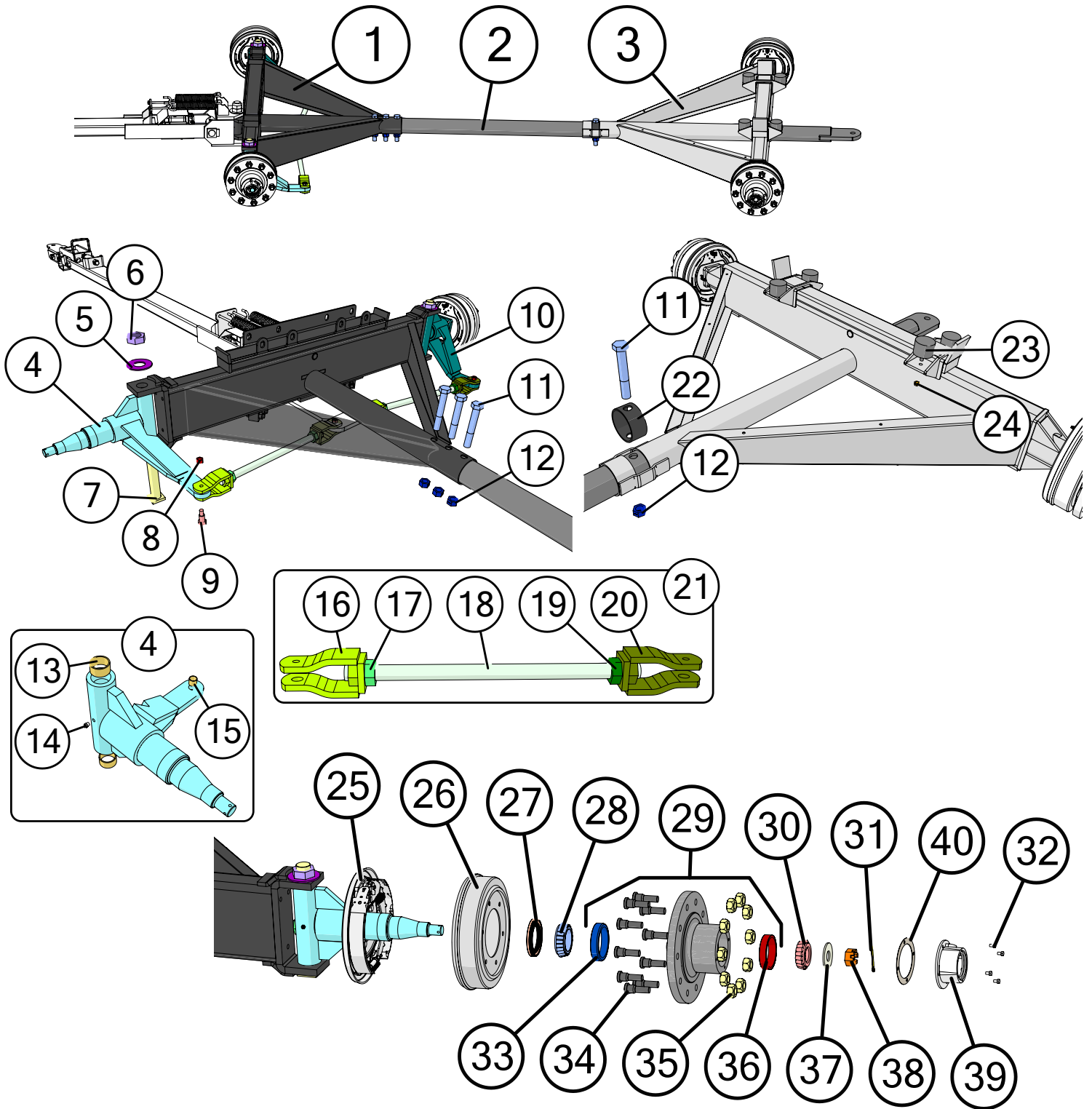

# 24 Ton Running Gear

	Description	Part No.
1	55 Series 24 Ton Front Axle Weldment	JM0033950
2	Coupling Pole (144" x 4" OD Pipe) (655, 755)	JM0033947
3	55 Series 24 Ton Rear Axle Weldment	JM0033953
4	55 Series 24 Ton Front Left A-Frame Arm	JM0035126
5	1-3/4" USS Flat Washer	JM0029723
6	1-3/4"-5 Gr5 Z Hex Nut	JM0019334
7	Spindle Bolt (1-3/4" x 14-1/2") (12-15 Ton) (SPB-134)	JM0019321
8	5/8"-11 Gr2 Z Hex Nut	JM0001522
9	7/8" Shoulder Dia x 1-3/8" Shoulder Length x 5/8"-11 Shoulder Bolt and Nut (SB-78)	JM0029199
10	55 Series 24 Ton Front Right A-Frame Arm	JM0035128
11	1"-8 x 6-3/4" Gr5 Z Hex Bolt	JM0029381
12	1"-8 Gr2 Z Centerlock Hex Nut	JM0002149
13	1-3/4" ID Bronze Bushing (2" OD x 1" Length) (EB-134)	JM0002244
14	1/8" NPT Male x 11/16" Straight Grease Fitting	JM0009756
15	7/8" ID x 1" OD x 7/8" LG Bronze Bushing (BB-78)	JM0029185
16	1-1/4" Left Tie Rod End (Clevis) (TRE-114L)	JM0029192
17	1-1/4"-12 Gr5 PN LH Hex Nut	JM0019931
18	1-1/4" x 24" 24 Ton Tie Rod (TR-24A)	JM0029187
19	1-1/4"-12 Gr5 PN RH Hex Nut	JM0019930
20	24 Ton Right Clevis Weldment (TRE-114R)	JM0029191
21	24T Tie Rod Assembly	JM0029194
22	4-1/2" Collar to Coupling Pole (CL-412)	JM0015724
23	Rubber Damper (1/2"-13 x 1-1/4" Stud)	JM0031630
24	1/2"-20 Gr2 Z Centerlock Hex Nut	JM0009858
25	Drum Brake Cluster Assembly (Left) (DRBA-L)	JM0027922
25	Drum Brake Cluster Assembly (Right) (DRBA-R)	JM0027931
26	13" Brake Drum - 873 Hub (6" Pilot)	JM0029510
27	Cassette Seal 4-5/8" OD x 3-3/8" ID for G873 (334655VST16)	JM0059340
28	Large Bearing (4T-33275)	JM0025687
29	873 Hub with Studs, Lugs & Races (Brakes) (W-871B)	JM0029503
30	Small Bearing (4T-460)	JM0025688
31	3/16" x 2-1/2" Cotter Pin	JM0027684
32	5/16"-18 x 1/2" Gr5 Z Hex Bolt	JM0016674
33	Large Race (4T-33462)	JM0025689
34	3/4"-16 x 1-3/4" Wheel Stud	JM0018957
35	Wheel Nut 3/4"-16	JM0018958
36	Small Race (4T-453A)	JM0025695
37	1-3/10" ID x 3-1/4" OD x 3/16" Spindle Washer	JM0029511
38	1-1/4"-12 Gr2 Castle Hex Nut	JM0010113
39	873 Oil Bath Hub Dust Cap	JM0035157
40	Dust Cap Gasket G877	JM0043908

# 13" Brake Assembly for 24 Ton Running Gear

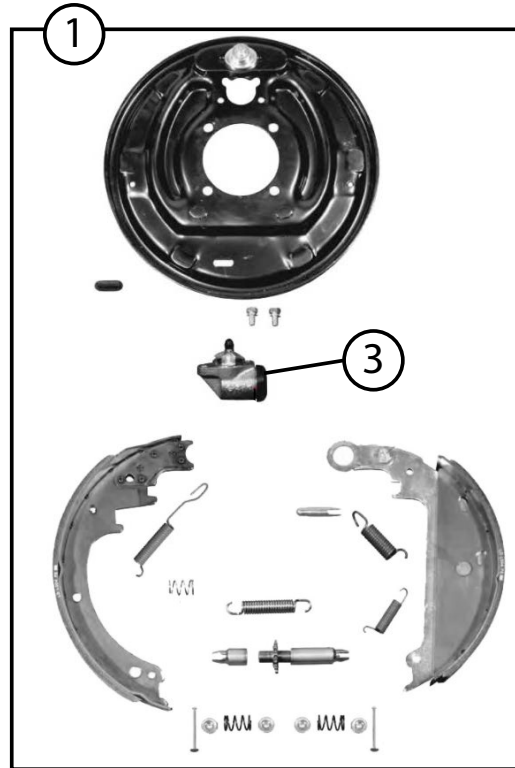
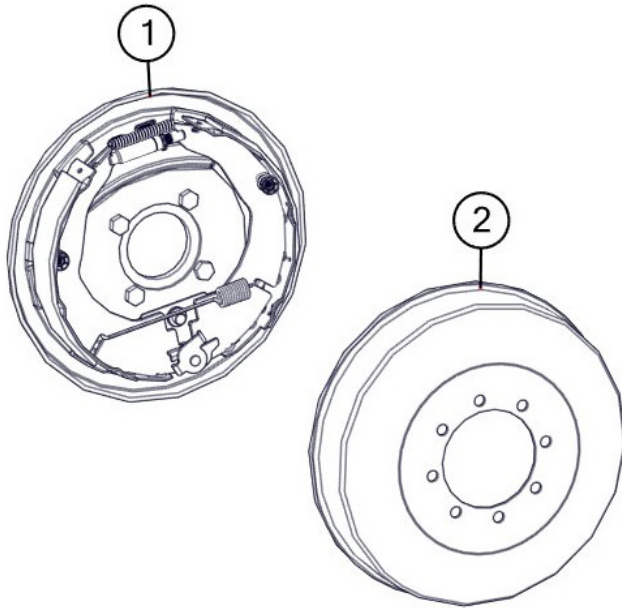

Description	Part No.
1 Drum Brake Cluster Assembly (Left) (DRBA-L)	JM0027922
1 Drum Brake Cluster Assembly (Right) (DRBA-R)	JM0027931
2 13" Brake Drum - 873 Hub (6" Pilot)	JM0029510
3 Wheel Cylinder Assembly, Left (Drum Brakes) (9777)	JM0027939
3 Wheel Cylinder Assembly, Right (Drum Brakes) (9776)	JM0027938
4 1/4" x 25" Hydraulic Hose	JM0027968
5 30" x 3/16" Brake Line with Nut on Both Ends	JM0029559
6 120" x 3/16" Brake Line with Nut on Both Ends	JM0029565
7 3/16" x 53" Brake Line	JM0027970
8 2" x 3/16" Brake Line with Nut on Both Ends, Tee Extension	JM0029562
9 Brake Line Tee (10606)	JM0027967

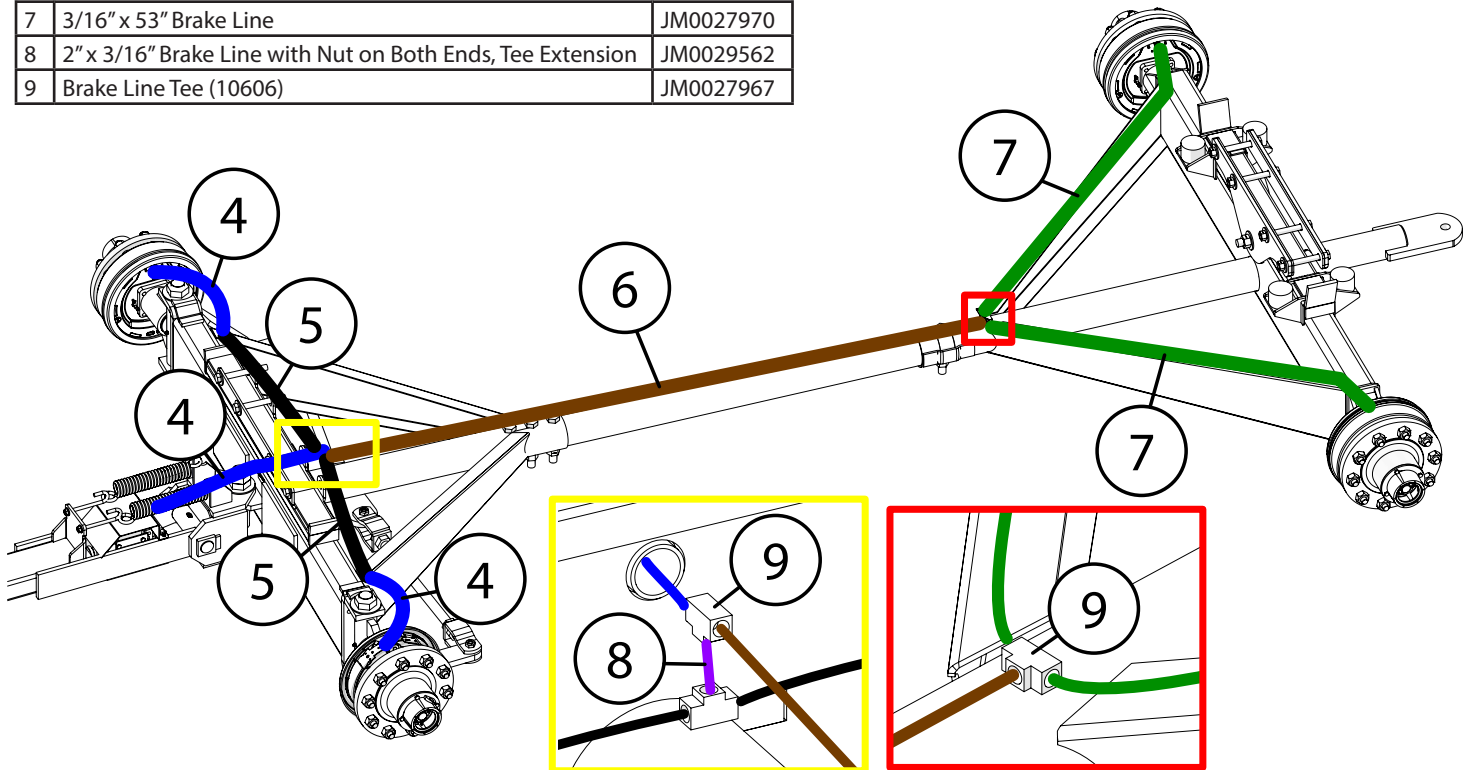

# 24 Ton Rocking Bolster

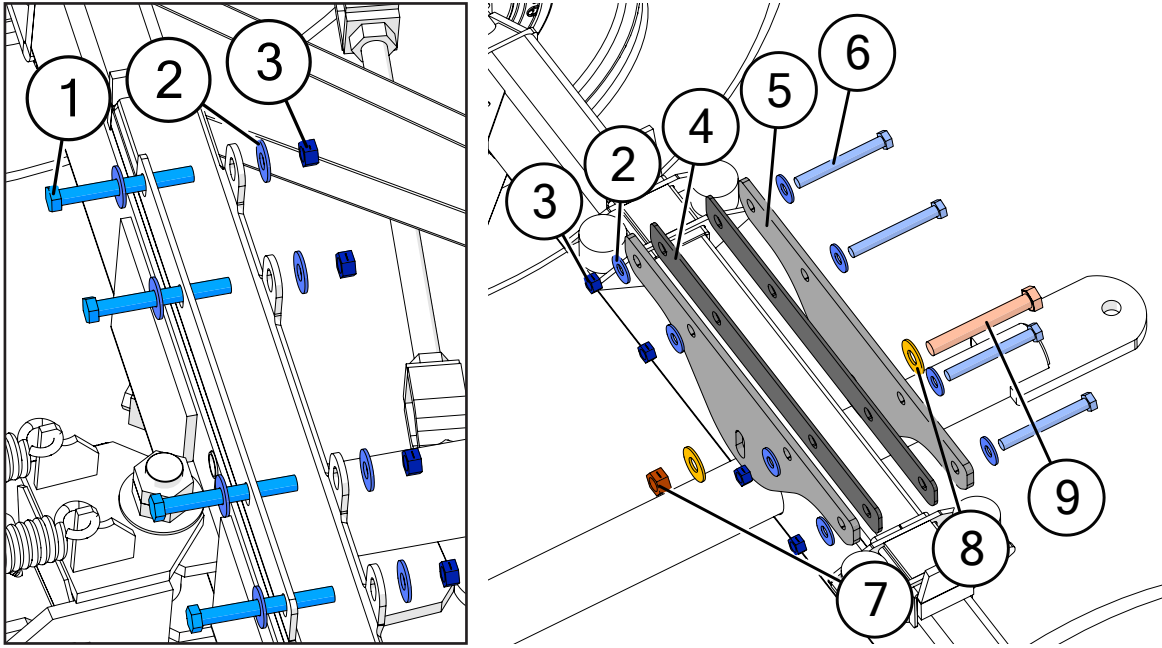

Description	Part No.
1 3/4"-10 x 6-1/2" Gr5 Z Hex Bolt	JM0016684
2 3/4" USS Z Flat Washer	JM0010006
3 3/4"-10 Gr2 Z Centerlock Hex Nut	JM0002147
4 24 Ton Back Rocking Bolster - Spacer	JM0032503
5 24 Ton Back Rocking Bolster	JM0032500
6 3/4"-10 x 7" Gr5 Z Hex Bolt	JM0054907
7 7/8"-9 Gr2 Z Centerlock Hex Nut	JM0002148
8 1" USS Flat Washer Gr8 Z & Y	JM0076795
9 7/8"-9 x 8" Gr8 YZ Hex Bolt	JM0019392

# Shell Assembly

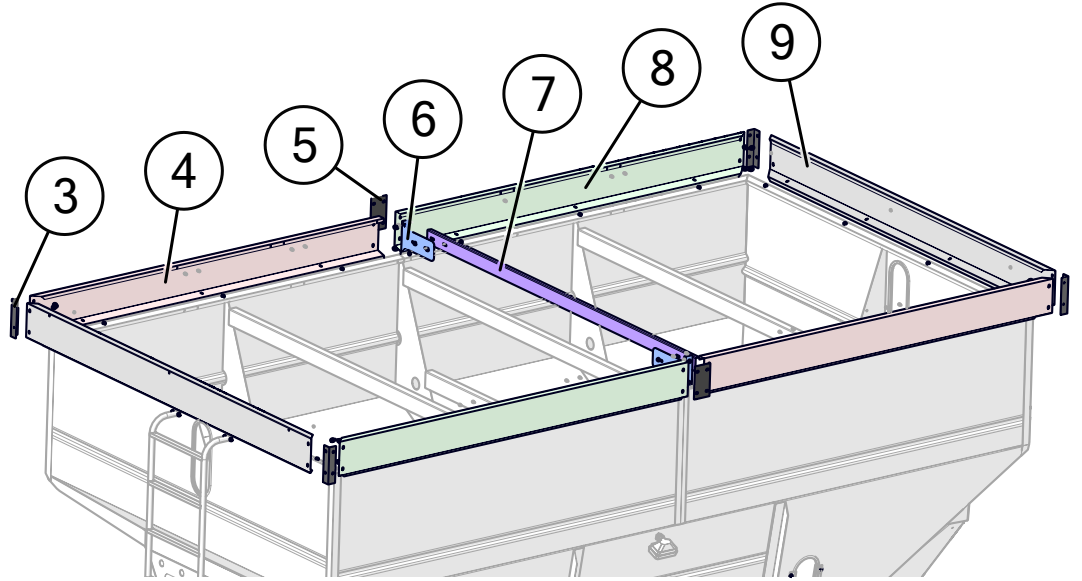
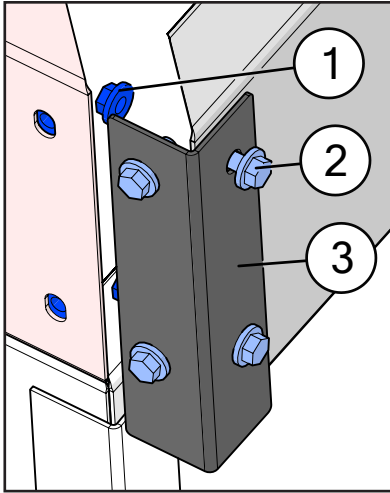

755 Divider Option Only

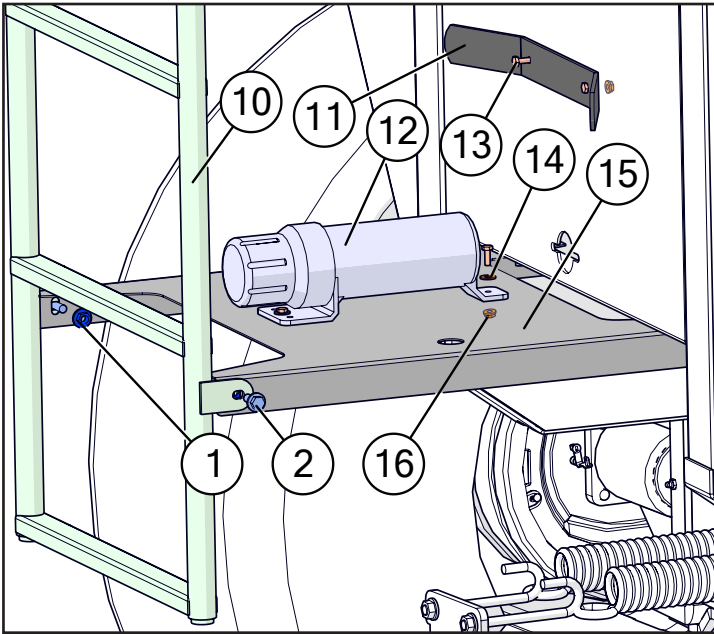
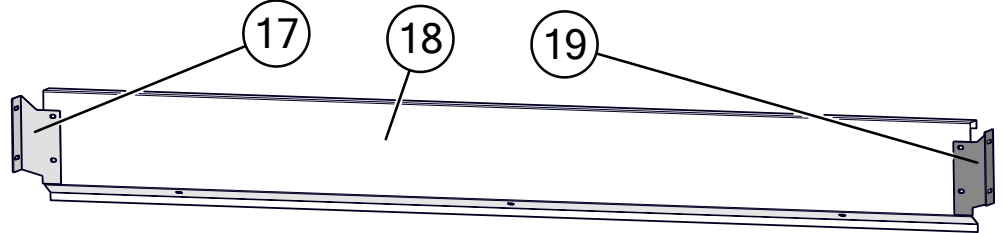

# Shell Assembly

	Description	Part No.
1	3/8"-16 Gr5 Z SF Hex Nut	JM0002152
2	3/8"-16 x 1" Gr5 Z SF Hex Bolt	JM0002092
3	755 Sideboard Corner (9-1/2")	JM0034351
4	755 Front Passenger or Rear Driver Sideboard (105-1/2" Length)	JM0034313
5	755 Sideboard Splice Plate (8-1/2" x 4-5/8")	JM0034319
6	755 Sideboard Brace End	JM0034320
7	755 Sideboard Brace	JM0034321
8	755 Front Driver or Rear Passenger Sideboard (105-1/2" Length)	JM0034317
9	755 Endboard (114-1/2" Length)	JM0034315
10	Ladder Weldment (655, 755)	JM0034378
11	Wire Harness Storage Bracket (WHB-1)	JM0001438
12	Operator's Manual Canister	JM0010115
13	1/4"-20 x 1" Gr5 Z Hex Bolt	JM0002095
14	1/4" ID, 3/4" OD Z Flat Washer	JM0003090
15	55 Series Ladder Brace	JM0034491
16	1/4"-20 Gr5 Z SF Hex Nut	JM0001630
17	755 Passenger Side Divider End	JM0036017
18	755 Divider Sideboard	JM0036015
19	755 Driver Side Divider End	JM0036024

# Door Wheel Assembly

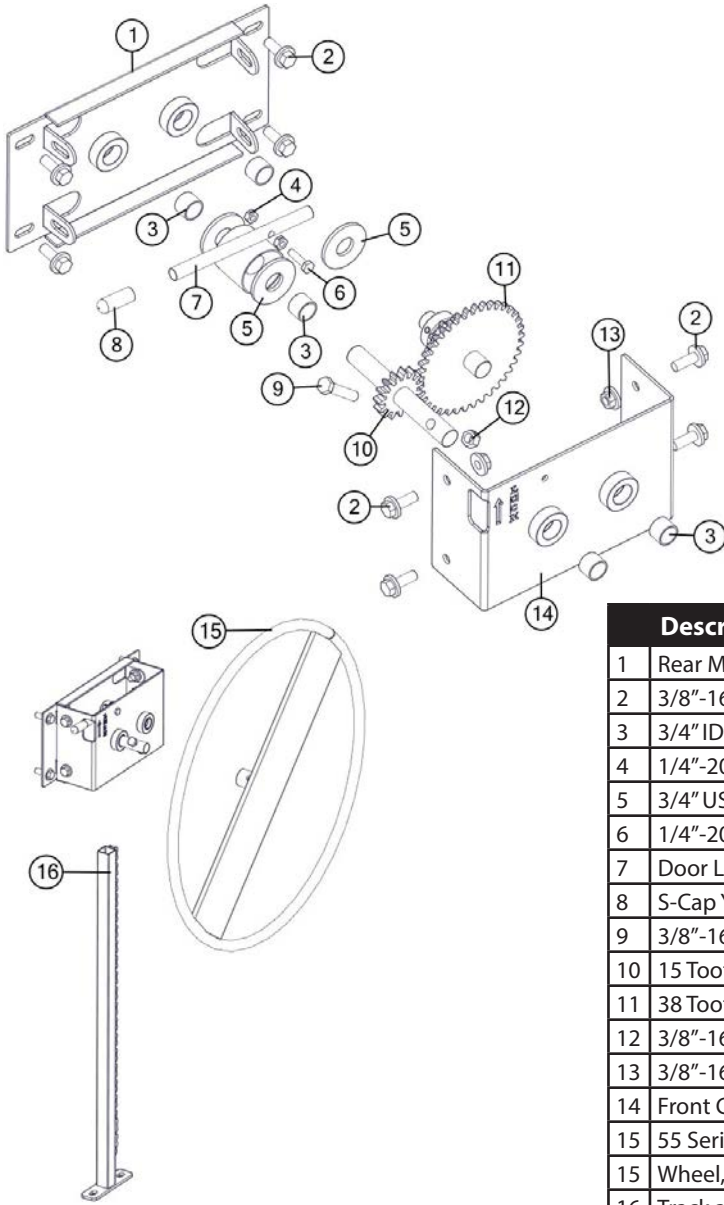

	Description	Part No.
1	Rear Mounting Plate (RMP-1)	JM0028412
2	3/8"-16 x 1" Gr5 Z SF Hex Bolt	JM0002092
3	3/4" ID x 7/8" OD x 5/8" LG Bronze Bushing (BB-34)	JM0009455
4	1/4"-20 Gr2 Z Centerlock Hex Nut	JM0001505
5	3/4" USS Z Flat Washer	JM0010006
6	1/4"-20 x 1" Gr5 Z Hex Bolt	JM0002095
7	Door Locking Rod (DLR-1)	JM0019097
8	S-Cap Yellow - 1/2" ID x 1-1/4" x 0.065" (REC-1)	JM0016842
9	3/8"-16 x 1-3/4" Gr5 Z Hex Bolt	JM0002097
10	15 Tooth 3/4" Bore Gear with Shaft Weldment (15TSS)	JM0028411
11	38 Tooth Sprocket with Shaft (Gear Reduction Rack)	JM0028410
12	3/8"-16 Gr2 Z Centerlock Hex Nut	JM0001512
13	3/8"-16 Gr5 Z SF Hex Nut	JM0002152
14	Front Cover Plate for Gravity Box Door (FCP-1)	JM0028409
15	55 Series 24" Door Rack Wheel	JM0035347
15	Wheel, Pin and Strap Assembly for 16-3/4" Door Rack Wheel (WPS-1)	JM0028404
16	Track and Chain Assembly (TCA-28)	JM0028403
17	Gear Reduction Wheel Assembly (Minus Track & Chain)	JM0033488

# Inspection Windows

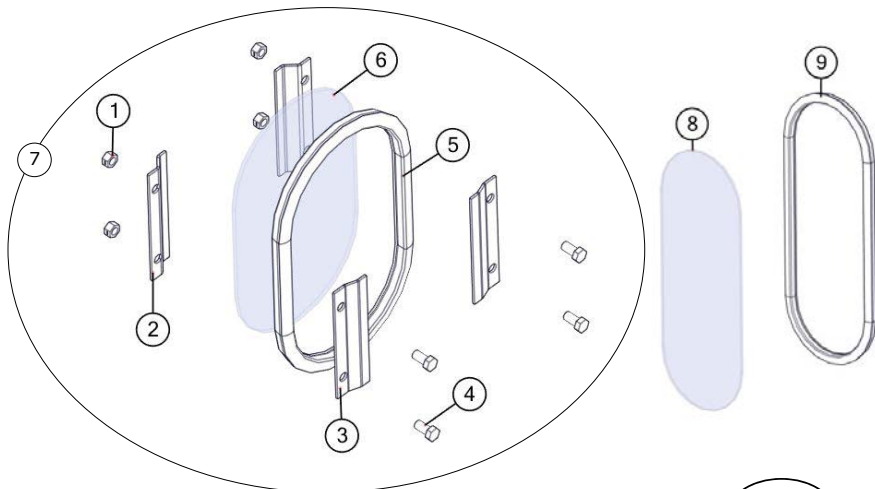

	Description	Part No.
1	3/8"-16 Gr2 Z Centerlock Hex Nut	JM0001512
2	Inside Window Clip - Deep	JM0000253
3	Outside Window Clip - Shallow	JM0000256
4	3/8"-16 x 3/4" Gr5 Z Hex Bolt	JM0001663
5	Window Seal 3/4" S' Strip	JM0000254
6	Standard Inspection Window	JM0000255
7	Inspection Window Kit	JM0025752
8	Oval Window XL - 18-3/4"	JM0033502
9	Oval Window Grommet (Long Oval Window)	JM0033504



# Door Assembly

Non-Divider Option

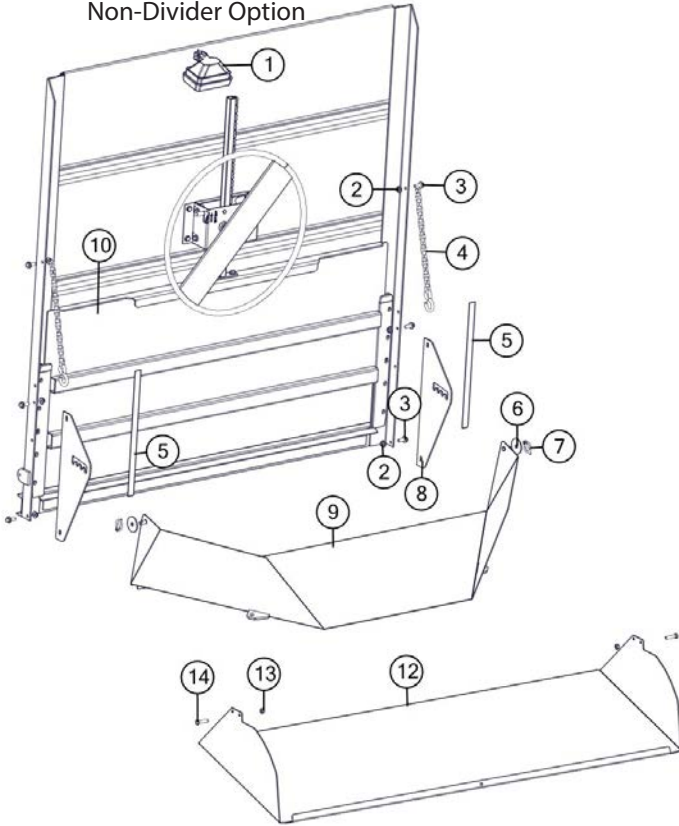

Divider Option

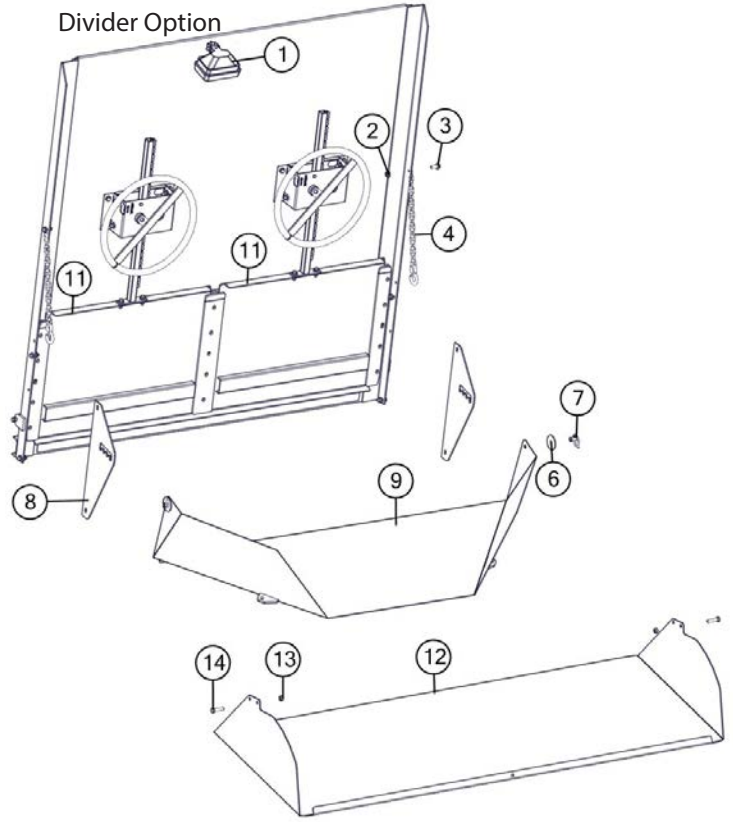

Metering Door Option

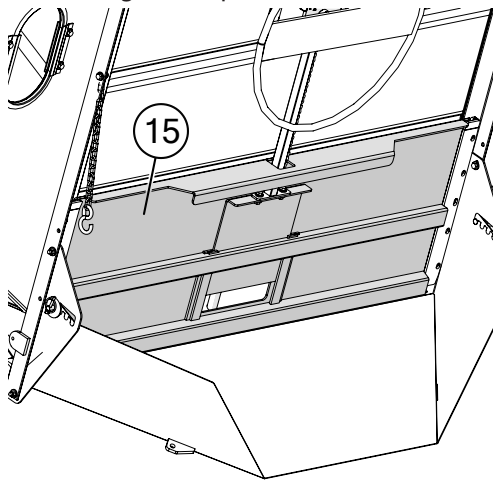

Description	Part No.
1 LED Field Light with Bullet Connector	JM0050949
2 3/8"-16 Gr5 Z SF Hex Nut	JM0002152
3 3/8"-16 x 1" Gr5 Z SF Hex Bolt	JM0002092
4 3/16" x 17" Chain with S-Hook (31617-CS)	JM0019107
5 1" Wide Poly Tape (55 Series)	JM0035980
6 1/2" ID x 2-1/4" OD Flat Washer - 1/8" Thick	JM0019081
7 1/4" Diameter Snap Ring	JM0001870
8 Adjustable Chute Bracket for 60" Door	JM0035050
9 Side Dump Chute Weldment - 60" Door	JM0031201
10 55 Series Non Metering Door Weldment	JM0032062
11 55 Series Divider Door Weldment	JM0036037
12 55 Series Center Dump Chute	JM0031209
13 3/8"-16 Gr5 Z Hex Nut	JM0001707
14 3/8"-16 x 1-1/2" Gr5 Z Hex Bolt	JM0001659
15 Metering Door Weldment for 55 series Gravity Wagon	JM0031054

# Lights

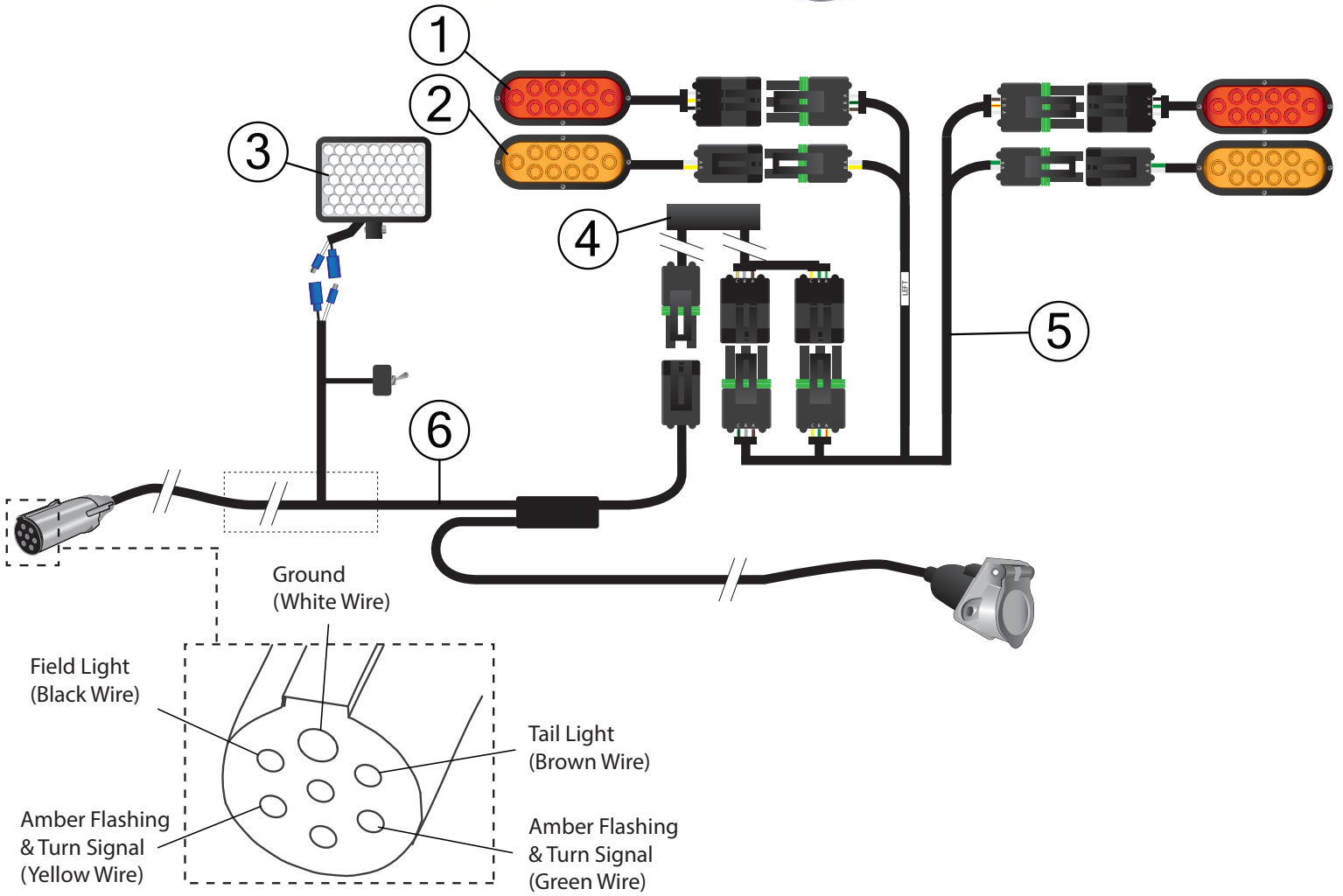
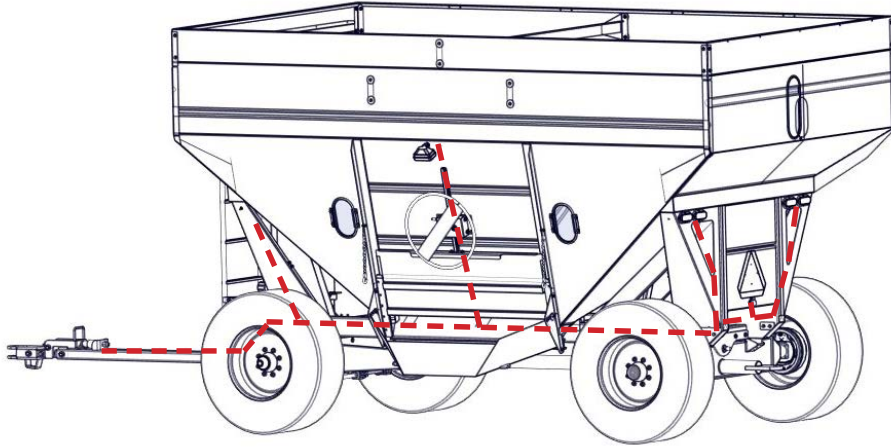

Description	Part No.
1 Red Oval LED Tail Light	JM0034389
2 Amber Oval LED Tail Light	JM0034392
3 LED Field Light with Bullet Connector	JM0050949
4 Light Enhancer and Adapter Kit (3 Wires)	JM0010566
5 Gravity Box Light Wiring Harness (LH-1)	JM0027773
6 Main Wiring Harness for Gravity Box (WN-1N)	JM0027774

# Spring Return Assembly

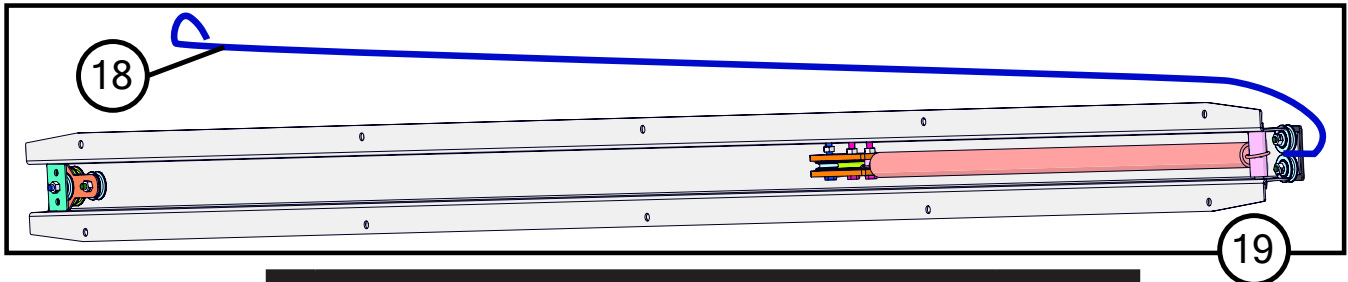
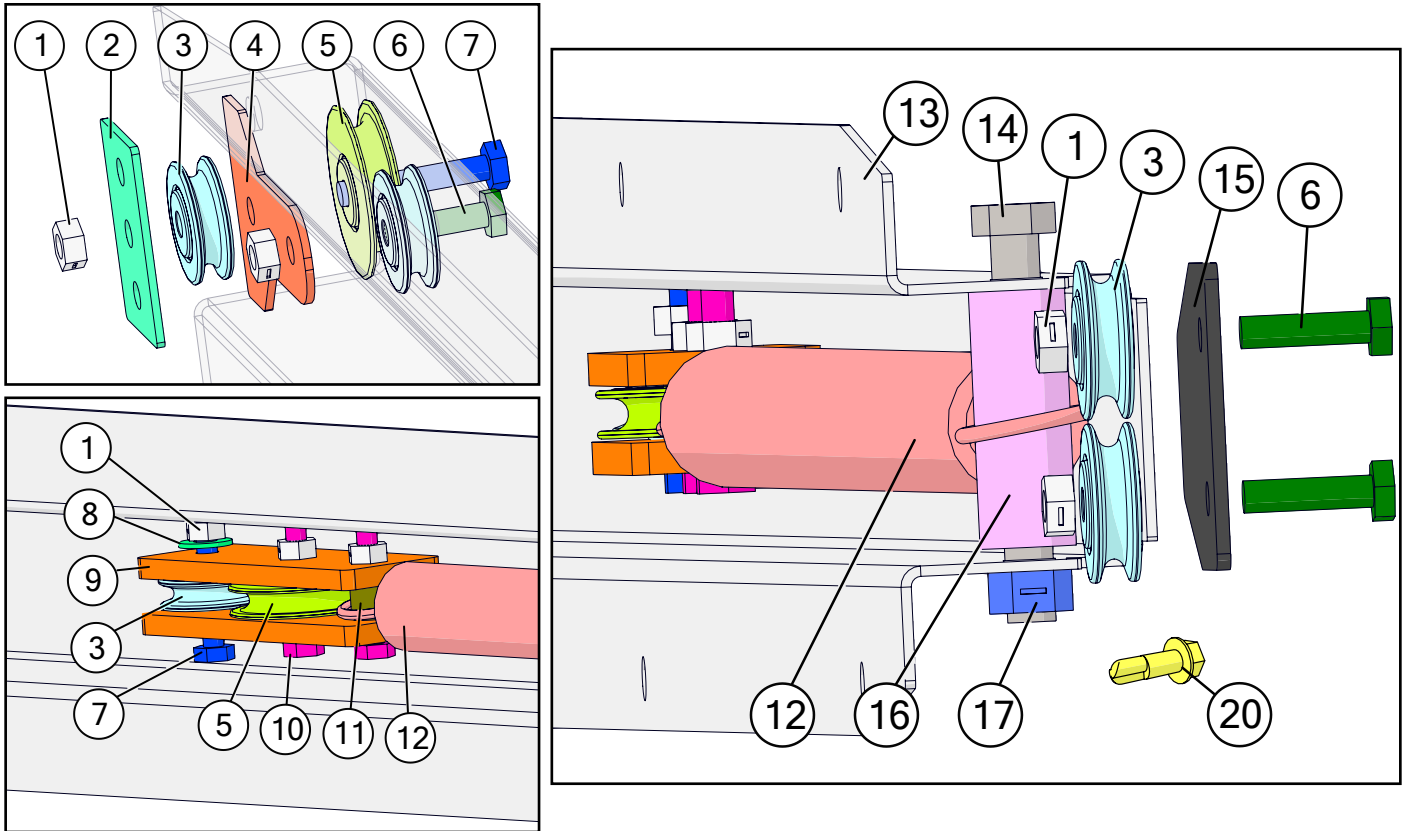

	Description	Part No.
1	1/4"-20 Gr2 Z Centerlock Hex Nut	JM0001505
2	Aluminum Spacer for Spring Return (1-3/8" x 2-3/16") Rectangular	JM0002445
3	1-1/4" Idler Pulley (1/4" ID)	JM0002439
4	Large Spring Return Pulley Spacer (2 Holes)	JM0018897
5	1-5/8" Idler Pully (Long Spring Return)	JM0012970
6	1/4"-20 x 1" Gr5 Z Hex Bolt	JM0002095
7	1/4"-20 x 1-1/2" Gr5 Z Hex Bolt	JM0002447
8	1/4" ID, 3/4" OD Z Flat Washer	JM0003090
9	Rectangular Plastic Spacer for Spring Return	JM0012973
10	1/4"-20 x 1-1/4" Gr5 Z Hex Bolt	JM0016673
11	2" Black Plastic Spacer (1/4" ID x 1/2" OD)	JM0002442
12	Spring Return Spring	JM0000207
13	Spring Return Housing for Grain Cart Roll Tarp	JM0012974
14	3/8"-16 x 3" Gr5 Z Hex Bolt	JM0001666
15	Spring Return Stiffening Plate	JM0034548
16	3/4" x 2" Plastic Spacer	JM0002444
17	3/8"-16 Gr2 Z Centerlock Hex Nut	JM0001512
18	Spring Return Cable (Grain Carts)	JM0012981
19	Spring Return Assembly Complete (Grain Cart, 655, 755)	JM0002911
20	1/4" x 3/4" Self Tapping Screw	JM0001570

# Roll Tarp

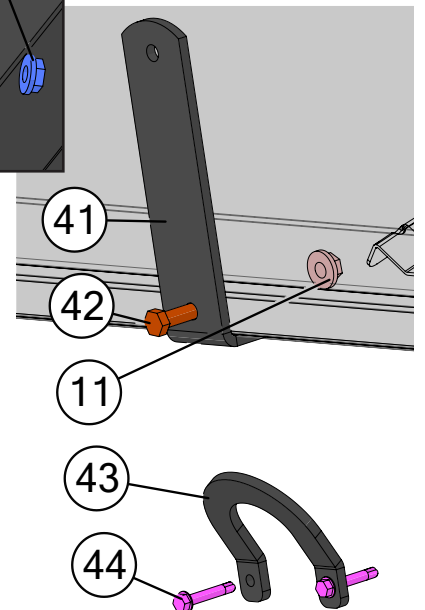
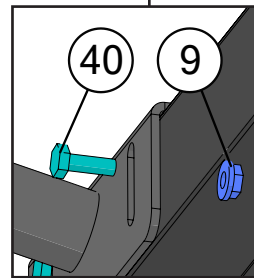
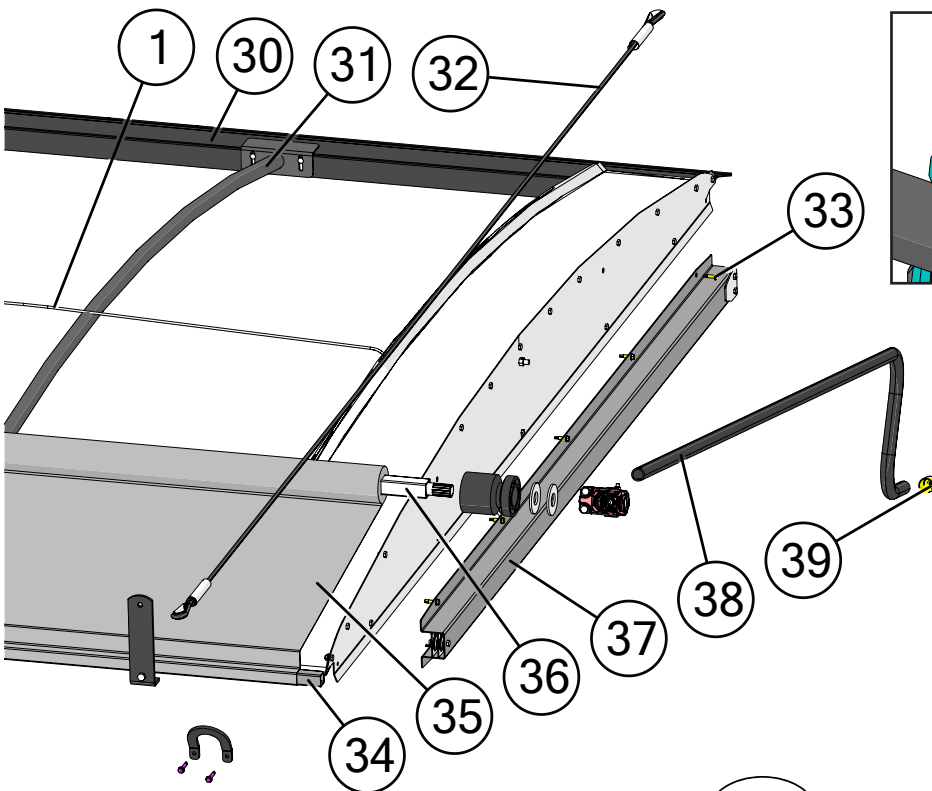
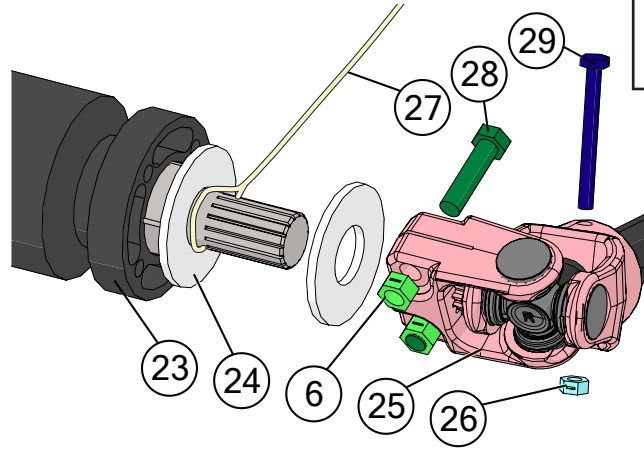
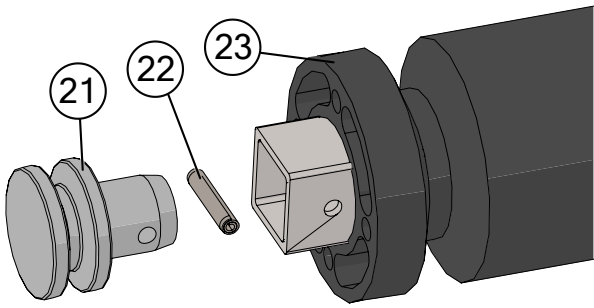
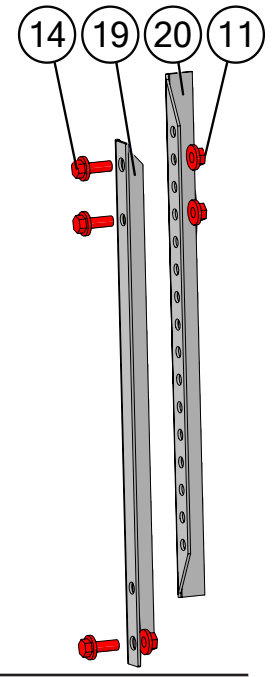
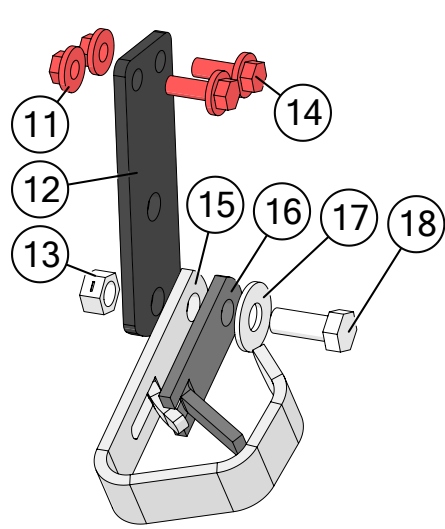
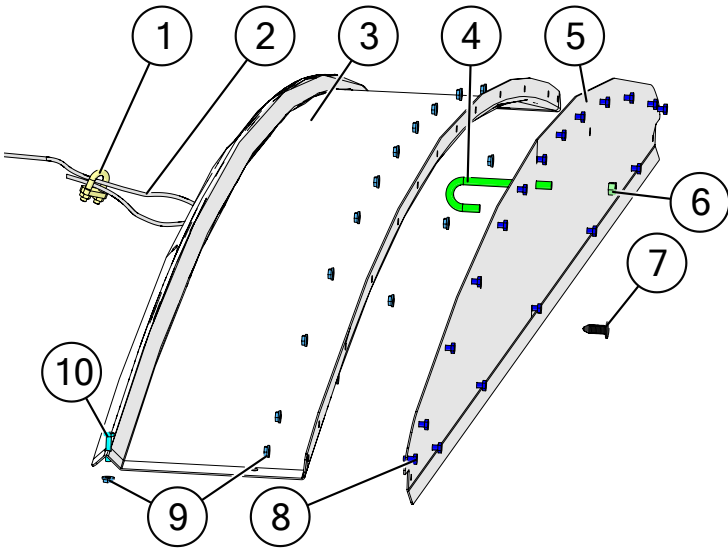

# Roll Tarp

	Description	Part No.
1	1/8" Cable Clamp	JM0001514
2	3/16" Cable x 210" (655, 755)	JM0036045
3	Arched Top Endcap 655/755 Glide Right 114-1/2"	JM0046442
4	3/8"-16 x 2-3/8" Thread Length x 5" Overall Length Gr5 Z J-Bolt	JM0001519
5	Endcap Plate 655/755 Glide Right 114-1/8"	JM0046441
6	3/8"-16 Gr2 Z Centerlock Hex Nut	JM0001512
7	3/8" Ribbed Push in Rivet	JM0037396
8	1/4"-20 x 1/2" Gr5 Z Hex Bolt	JM0001481
9	1/4"-20 Gr5 Z SF Hex Nut	JM0001630
10	1/4"-20 x 1-1/4" Gr5 Z Hex Bolt	JM0016673
11	3/8"-16 Gr5 Z SF Hex Nut	JM0002152
12	Adjustable Bar for Crank Holder Gravity Wagon (ABCH-1)	JM0000815
13	1/2"-13 Gr2 Z Centerlock Hex Nut	JM0001511
14	3/8"-16 x 1" Gr5 Z SF Hex Bolt	JM0002092
15	Crank Holder (Zinc Plated) (CH-1)	JM0002967
16	Roll Tarp - Handle Hanger Rubber Flap	JM0002551
17	1/2" ID, 1-3/8" OD Z Flat Washer	JM0003082
18	1/2"-13 x 1-1/4" Gr5 Z Hex Bolt	JM0001513
19	Endcap Prop - Lower 19" (ABS-2)	JM0000179
19	Endcap Prop - Lower 27" (ABS-2L)	JM0021403
20	End Cap Prop - Upper 19"	JM0021404
21	Spool End for Roll Tube (2" Long x 1-3/4" O.D.)	JM0002449
22	1/4" x 1-1/4" HD Spiro Roll Pin	JM0046782
23	Roll Tarp Guide Roller (4-1/8" Long x 3-1/4" O.D.)	JM0038446
24	1" USS Flat Washer	JM0003063
25	Universal Joint - Roll Tarp (SUJ-1)	JM0001517
26	1/4"-20 Gr2 Z Centerlock Hex Nut	JM0001505
27	Spring Return Cable (Seed Tender and Gravity Boxes)	JM0010307
28	3/8"-16 x 1-1/2" Gr5 Z Hex Bolt	JM0001659
29	1/4"-20 x 2-1/2" Gr5 Z Hex Bolt	JM0001506
30	Tightening Lip (655, 755) Front	JM0034342
30	Tightening Lip (655, 755) Rear	JM0034542
31	655/755 Box Bow Weldment (110-1/2")	JM0034349
32	Tarp Rope Assembly 12'2" Glide Right Boxes	JM0049448
33	1/4" x 3/4" Self Tapping Screw	JM0001570
34	Square Tie-Down Tube for 655/755 Roll Tarp	JM0034383
35	655/755 Glide Right Roll Tarp with 10 Rivets	JM0048599
36	1-1/4" x 214" Roll Tube for Glide Right (655, 755)	JM0048427
37	Spring Return Assembly Complete (Grain Cart, 655, 755)	JM0002911
38	93-1/4" Crank Handle (ST375CH)	JM0002907
39	S-Cap Yellow - 1.062" ID x 1-1/2" x 1/16"	JM0018963
40	1/4"-20 x 1" Gr5 Z Hex Bolt	JM0002095
41	Tarp Stop Bracket (TSB-1)	JM0000187
42	3/8"-16 x 2" Gr5 Z Hex Bolt	JM0001510
43	Tarp Rope Bracket	JM0047700
44	1/4" x 1-1/2" Self Tapping Screw	JM0001571