



6000 Series NitroGro Nitrogen Applicators



NitroGro™ 6026 with 30" row spacing

Place Your

NITROGEN

Where It Counts...When It Counts



6000 SERIES MODELS

6018 • 6026

6018 6026

NitroGro
6000 Series Nitrogen Applicators



Model 6018 with Single Wheel Undercarriage

Model 6018S Nitro-Gro liquid fertilizer applicator featuring a narrow 11'-9" transport width, custom designed 1,850 gallon tank capacity and extra deep sump, 55' - 62' -4" working toolbar widths with 20", 22" or 30" row spacings, single wheel undercarriage with VF380/90R46 tires (30" row spacing) or 320/105R46 tires (20" or 22" row spacing), high strength 5" x 7" toolbar with equal length hydraulically folding wings with hydraulic wing kick and hydraulic down pressure, 3" tank fill tube, 9 Gallon Safety Rinse Tank, heavy duty GEP coulters with knife and orifice kit (includes #75 installed, #107 and #132 orifices for each coulter), ACE 150-206F hydraulic pump with Raven Flowmeter, Flow Control Valve, Raven 5-Section Control Manifold, diaphragm boom shut-off valves at each coulter, and Boom Product Control cable, and single reach tongue. Available in Red or Green finish. **Controller Not Included in Base Unit.**

Model 6018 and 6026 with Walking Tandem Dual Wheel Undercarriage

Model 6018D or 6026D Nitro-Gro liquid fertilizer applicator featuring a narrow 11'-9" transport width, custom designed 1,850 or 2,600 gallon tank capacity, 55' - 62' -4" toolbar widths with 20", 22" or 30" row spacings, with walking tandem dual wheel undercarriage and VF380/90R46 tires (30" row spacing) or 320/105R46 tires (20" or 22" row spacing), high strength 5" x 7" toolbar with equal length hydraulically folding wings with hydraulic wing kick and hydraulic down pressure, 3" tank fill tube, 9 Gallon Safety Rinse Tank, heavy duty GEP coulters with knife and orifice kit (includes #75 installed, #107 and #132 orifices for each coulter), ACE 150-206F hydraulic pump with Raven Flowmeter, Flow Control Valve, Raven 5-Section Control Manifold, diaphragm boom shut-off valves at each coulter, and Boom Product Control cable, and single reach tongue. Available in Red or Green finish. **Controller Not Included in Base Unit.**



NitroGro™ 6026 with 22" row spacing

Design Features

- Patent Pending wing design with customized wheel well tank offers an industry leading 11'-9" transport width and low 9'-1" or 10'-8" tank height. (11'-10" or 12'-10" overall transport height.)
- Shortest hitch to axle length (14'-0") allows the applicator to follow the tractor, creating just one set of tracks that reduces crop damage and eliminates the need for a steerable hitch option.
- 55' - 62' 4" working width with 20", 22" or 30" row spacings.
- Single Wheel or Walking Tandem Dual Wheel undercarriage with 10 bolt heavy duty hubs and narrow tongue design for greater turning radius. Easily accessible jack that pins away for storage.
- Low tank height for a lower center of gravity and greater stability
- High strength tool bar features dual 5" x 7" tubing
- Parallel linkage toolbar design keeps the coulters and knives in correct position to the ground at all times.
- 15 degree hydraulic wing kick reduces crop damage when turning
- Diaphragm shut-off valves at each coulter reduces fertilizer loss and crop "burn" damage on end rows.
- Coulters feature heavy duty square tube mounting pillars with high strength 5/8" U-Bolts and 8 bolt hubs on a 60 degree swivel for maximum performance.
- Front and rear sight glass for viewing tank fluid levels.
- 9 Gallon Safety Rinse Tank, 3" Fill Tube, Ace Hydraulic Pump and Raven 5 Section Control Manifold are standard on all models
- Optional Ball Flow Indicators, Knife or Nozzle Injectors or Straight or Wavy Coulters
- Tool-less gauge wheel height adjustment
- Recommended Horsepower: 275 hp to 410 hp
- Greaseless toolbar bushings for reduced maintenance.

1,850 or 2,600 GALLON
CUSTOM TANK



Stainless steel baffles keeps the weight properly distributed, even over uneven terrain.

"Nose" tank design keeps the weight forward to ensure the coulters remain at proper depth even in the toughest soils.

Tall 40" Toolbar Clearance for late application without risk of crop damage.

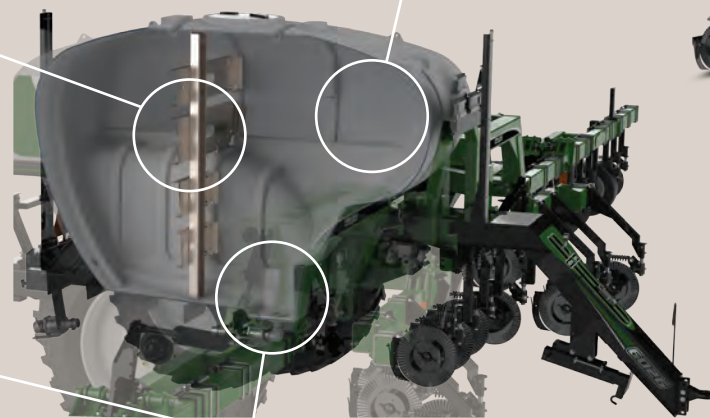
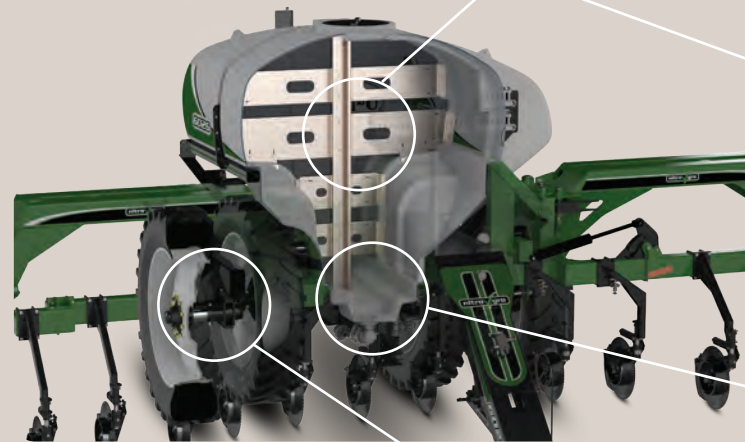

Exclusive walking tandem dual wheel undercarriage "walks" over rough and uneven terrain, allowing the coulters to stay at consistent depths for a more uniform application compared to rigid dual wheel undercarriages.

Standard on 6026 and optional on 6018.



Extra deep 10 gallon sump to ensure the pump remains primed

Knife or Injection Delivery

Choose from injectors or knives to consistently deliver nitrogen next to the root to minimize the risk of denitrification.

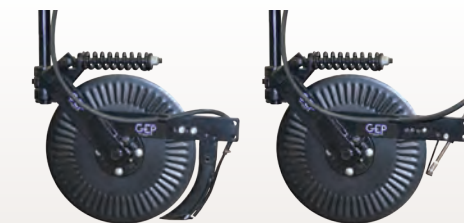

Knife Delivery

Injection Delivery



6000 Series NitroGro Nitrogen Applicators



Transport Height
11'-10" or 12'-10"



Patent Pending wing design with customized wheel well tank offers an industry leading 11'-9" transport width and low 9'-1" or 10'-8" tank height. (11'-10" or 12'-10" overall transport height.)



Parallel linkage toolbar design keeps the coulters and knives in correct position to the ground at all times. Wing sections allow 15 degree upward movement and 10 degree downward movement for consistent application over uneven terrain.

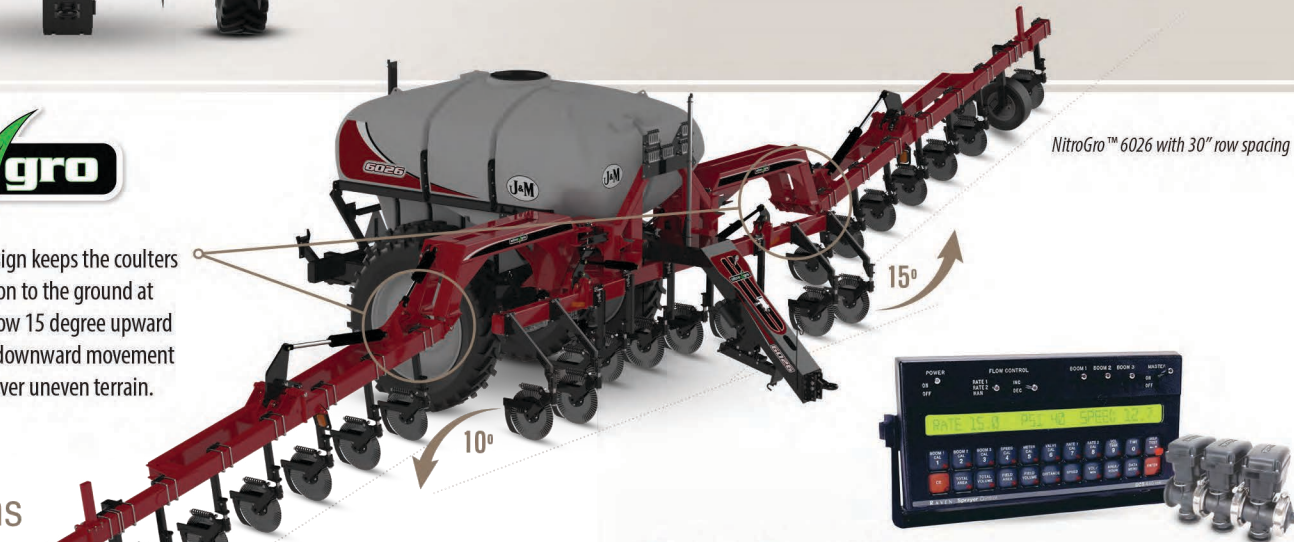

Specifications

MODEL	1850	2600
Transport Width	11'9"	11'9"
Transport Length	25'	25'
Transport Height	11'10"	12'10"
Height to Top of Tank	9'1"	10'8"
Empty Weight (lbs)	18,500	19,000
Hitch to Axle	14'	14'
Toolbar Ground Clearance	40"	40"
HP Suggested for 30" Rows w/ Knives	275 to 410	



Raven Controller (optional)

The SCS 450 automatically maintains the rate regardless of speed changes. The SCS 450 consoles include a 10 year non-volatile memory to maintain settings even with an extended loss of power.

750 Pump (optional)

ACE 750-22M PWM pump in place of standard ACE 150 pump. Includes additional harness and solenoid for higher volume and precise control.



J&M Manufacturing, Inc

284 Railroad Street • Fort Recovery, Ohio 45846
(419) 375-2376 • fax: (419) 375-2708 • sales@jm-inc.com • www.jm-inc.com

Specifications are subject to change without notice or obligation. ® Registered Trademark of J.&M. Mfg., Co. Inc.