



J&M Manufacturing
Premium Seed Tenders

The Most Advanced

SEED DELIVERY

Systems For Your Farming Needs



speedtender
ADVANCED SEED DELIVERY

MODELS EC 270 | LC 290 | LC 390 | LC 535 | 251 | 451 | C4-50



Their Upgrades Our **STANDARDS**

The SpeedTender Seed Delivery System by J&M has become the best seed tender on the market by helping farmers increase their planting efficiency. The extra-long conveyor can quickly and gently dispense seed to the widest and tallest planters, then rotate 180° for easy self-filling. A patented V-Belt and skirting design keeps the belt centered, reducing seed damage and the chance of premature wear due to misalignment. The larger tank opening makes it easy to completely refill, while keeping the center of gravity low for greater stability. The LC 290, 390 and 535 tenders all have LED work lights on the tank and conveyor for night time unloading. Optional scales and luxury controls allow you to customize the tender to fit your precise planting operation, saving time and money.

LC SERIES SPEEDTENDERS™

The redesigned tank and patented support arm result in a larger capacity tank with lower overall height. This allows you to carry more seed with a lower center of gravity while also making it easier to fill and more stable over uneven terrain.

The longer conveyor with large diameter round tube belt design makes it easy to reach the tallest central fill and widest box row planters. Our patented Tru-Trak with V-Belt conveyor is designed to reduce seed damage and premature wear on the conveyor belt due to misalignment.

J&M SpeedTenders make your planting season EFFICIENT AND EASY. That is why we've included many of the competitor's upgrades into our standard models. Don't be fooled by their lower prices, as it's probably not an "apples to apples" comparison.

LG - LARGER CAPACITY

The LC SpeedTender's™ larger capacity allows you to transport more seed and keeps you on the go during the busy planting season.

LG - LUXURY CONTROLS

A) Standard All-Function Remote

- Starts/Stops Conveyor
- Raises/Lowers Conveyor
- Opens/Closes Tank Doors
- Hydraulically Swings Conveyor



B) Optional Deluxe Wireless Remote

- Starts/Stops Conveyor
- Raises/Lowers Conveyor
- Opens/Closes Tank Doors
- Hydraulically Swings Conveyor
- Remote Scale Shut-Off¹
- Remote Auto Dispense¹
- Remote Conveyor Speed Control²



C) WC3-D SpeedTender Scale & Wireless Control System

- Starts/Stops Conveyor
- Raises/Lowers Conveyor
- Opens/Closes Tank Doors
- Hydraulically Swings Conveyor
- Remote Scale Shut-Off
- Remote Auto Dispense
- Remote Conveyor Speed Control
- Remote Talc Dispense
- Wireless Engine Start/Stop
- Opens/Closes Electric Roll Tarp
- Auto Bin Tracking



¹ Must be equipped with Weigh-Tronix scale system.

² Optional conveyor speed control adjustment located on conveyor.

VARIABLE SPEED CONTROL

Available On Both Standard And Upgraded Controls



LC - LOWER CENTER OF GRAVITY

The LC Series has been designed with a lower overall height and a lower center of gravity, making filling easier and transport more stable, especially over uneven terrain.

LC - LONGER CONVEYOR

The X-tra Long Conveyor offers greater reach and height to service the tallest and widest planters. A patented V-Belt and skirting design keeps the belt centered, reducing seed damage and chance of premature wear due to misalignment. The skirting design also reduces the potential of damaging seed and collecting debris. Competitor conveyor designs feature crowned rollers that allow the belt to "walk" back and forth, making it difficult to maintain alignment and prevent premature wear.



No Hassle Alignment



PATENTED SUPPORT ARM DESIGN

The patented design supports the conveyor from the top, providing better balance and making it easier for one person to rotate from the unload to self-fill positions. Supporting the conveyor from the top rather than underneath also allows the tank to be designed with a lower center of gravity for greater stability during transport.



An optional tandem axle undercarriage design is available for Model LC 390 and features a heavier torsion axle, wheels and tires for greater maneuverability and easier towing.



Optional Talc Applicator

Grooved Rollers for ultimate tracking

Hold Down Straps keeps tarp from flapping in wind

Front & Rear Return Springs for even tension reducing binding

GLIDERIGHT
ROLL TARP SYSTEM



speedtender
ADVANCED SEED DELIVERY

LC290 LC390 LC535

EC series

When The
ESSENTIALS
Are All You Need

J&M's new EC 270 SpeedTender™ gives you all the essentials you need for a fast and efficient planting season. The 270 cubic feet capacity bulk tank utilizes separate dual compartments and manual doors to easily change from one seed variety to another. The low profile tank makes filling easier and transporting more stable, especially over uneven terrain.

The 7" diameter unloading auger with poly-cup interior flighting is designed with an industry exclusive "bottom-less pit" design, reducing the cracking rate of seed to a minimum. A reliable, direct drive, 4.8 hp Honda electric start engine is conveniently located on the driver's side of the auger for easy operations and routine maintenance. A standard wired controller starts and stops the auger.

The sturdy undercarriage frame is supported by two 7,000 lbs suspension axles with electric brakes and 235/85R16 tires. The A-Frame front hitch with 2 5/16" ball and safety chains is standard, while an optional gooseneck hitch is also available.

A patent pending Glide Right roll tarp design keeps the roll tube aligned, making it easier to open and close. The over tarp tension cable maintains a tight seal during windy over the road transport while also keeping your seed safe and dry during storage.

When the essentials are all you need, the EC 270 SpeedTender delivers!



EFFICIENT & GENTLE POLY-CUPPED AUGER

Our poly-cupped auger system is designed to be gentle on your seed for minimum seed damage and maximum germination results.



EC 270

STANDARD FEATURES:

- 270 cubic feet capacity with dual compartments
- 7" diameter auger with poly-cup plastic flighting
- Industry exclusive "Bottom-less Pit" auger design significantly reduces seed breakage
- Manual door openers, auger swing and height positioning
- Patent pending Glide Right roll tarp design for easy opening and closing
- Two 7,000 lbs suspension axles with 235/85R16 tires
- 4.8 hp Honda electric start engine
- Front and rear auger storage

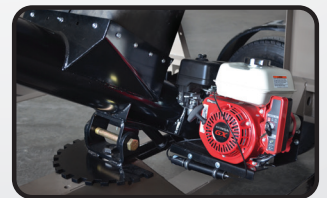

OPTIONAL FEATURES:

- Gooseneck hitch in place of standard A-Frame hitch
- 3-stage telescoping spout or 36" rubber spout
- Aluminum wheels in place of standard wheels
- Licensing package (includes license plate bracket and VIN number decal and certificate of origin)
- 5 Point scale system
- Lundell talc applicator



ALUMINUM WHEEL OPTION

speedtender
ADVANCED SEED DELIVERY

INDUSTRY EXCLUSIVE "BOTTOM-LESS PIT" AUGER DESIGN

Significantly Minimize Seed Damage

Our patent pending auger design eliminates seed cracking by extending the distance between the intake area and bottom end of the auger. This increased distance prevents seed that is not immediately carried up the auger from grinding and cracking at the bottom of the tube.

The poly-cup interior flighting is cup shaped to gently and quickly carry the seed up the auger. Interlocking sections make it easy to replace damaged flights, if necessary.

The outer tube and flighting diameters are also correctly sized to prevent seed from getting caught against the tube and cracking.

This design virtually eliminates the chance of cracking seed and gives you optimal performance for maximum germination rates when planting. This auger design rivals the performance of a typical round belt conveyor design, but without the inflated price tag.



ECHO DISPENSE SYSTEM

All other economy units use a linear actuator, so the operator has to hold the INCREASE throttle button to unload and DECREASE throttle button to stop. This can be extremely difficult to dispense seed accurately, especially with a row planter.

With J&M's Echo Dispense System, a single button automatically increases the throttle to the desired speed, ensuring greater accuracy. After the first box has been filled, simply press the "Echo" button to mimic the timing and easily fill the rest of the boxes consistently and evenly.

Compatible with our Talc Applicator.



GLIDE RIGHT ROLL TARP SYSTEM

The new Glide Right roll tarp is designed to offer greater protection of your valuable crops while making opening and closing quick and easy. The patent pending design keeps the tarp square and in line when turning the roll tube, eliminating the chance of binding and creating a tighter seal to keep moisture out and prevent the chance of wind flapping or lifting the tarp during transport.

Smoother Tracking

Grooved Rollers glide along the end caps for ultimate tracking, reducing the chances for misalignment.

Reduced Binding

Front and Rear Return Springs apply even tension in front and back to reduce binding compared to systems that use a single return spring.

Reduced Flapping

Hold Down Straps lay across the roll tarp to reduce the chance of wind flapping or lifting the tarp.



The
PREMIER
 Box Tender

J&M's SpeedTender Pro™ c4-50 is an elite pro box tender with the capacity to carry four 50 unit seed boxes effortlessly. The c4-50 features an x-tra long 22' conveyor to give the operator maximum unloading height and reach. The 8" tube allows seed to be transferred quickly and efficiently. The patented V-Belt and improved skirting designs keep the belt centered to reduce seed damage and the chance of premature wear, due to misalignment. The powerful 13 hp engine with electric start is conveniently placed for ease of use and routine maintenance. Trouble free guide plates and easy-to-use container latches make loading and unloading the c4-50 a breeze. During storage, the attached weather tight metal lids keep chutes dry and then quickly stow out of the way when loading seed boxes. Divided hoppers make planting multiple varieties simple. The SpeedTender Pro c4-50 is loaded with features that make it the premier box tender on the market today.



SpeedTender
Pro

c4-50

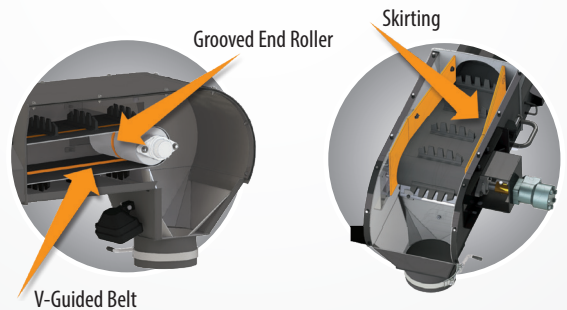

Grooved End Roller

Skirting

V-Guided Belt

TruTrak
V-Belt

PATENTED V-BELT CONVEYOR

Reduces Seed Damage and Maintenance

The unique conveyor design features a patented V-guided belt that is positioned in a recessed portion of the end rollers to ensure the belt remains centered, reducing the need for adjustment and minimizing the chance of seed damage, premature wear and added maintenance expense. Because the Tru-Trak belt consistently stays in alignment, the skirting at the top of the conveyor can be designed with a more precise fit that reduces the potential for seed damage and debris collection in the clean-out area.

No Hassle Alignment

22' EXTRA LONG, 8" WIDE CONVEYOR

Reach Higher and Wider

The extra long conveyor offers greater height and reach to service the tallest and widest planters.





CONVENIENT OPEN ENGINE PLACEMENT

13 hp Engine

Powered by a dependable 13 hp motor, the SpeedTender Pro c4-50 features the engine in front of the tender for easy access. Whether changing the oil, filling the gas, or turning the engine on or off, the open placement makes operation and maintenance easy and convenient.



ON-BOARD CONTROLLER

Keeps You on the Go

The standard on-board controller is a secondary control option for both the standard wired and optional wireless units in case the batteries fail, the remote is misplaced or a cord is damaged. The on-board controller can be used in conjunction with the current controls, allowing the operator to switch back and forth seamlessly, and has the optional talc applicator controls included.



STANDARD FEATURES

- 22' X-tra Long 8" Conveyor
- On-Board Controller
- Patented Tru-Trak V-Belt For No Hassle Alignment and Less Maintenance
- Attached Metal Weather Tight Lids
- 13 hp Engine
- Convenient Open Engine Placement
- Easy-To-Use Locking Container Latches
- Trouble Free Guide Plates For Easy Loading



AVAILABLE OPTIONS



- Choice of Durable Red, Green, Blue, Tan or Black Urethane Exterior Finish
- Choice of Standard Wire Remote or Deluxe Wireless Remote
- Choice of A-Frame, Gooseneck or Trailer Mount
- 2-Stage Telescoping Spout
- Optional Hydraulic Jack
- Electronic Weigh System (Weighs Seed From Tank For Empty Conveyor)
- Talc Applicator
- Working Lights for Night Time Unloading
- Divided Hopper For Quick and Easy Variety Changes

STANDARD & OPTIONAL CONTROLS

MODEL C4-50

A) Standard All-Function Remote

- Starts/Stops Conveyor
- Raises/Lowers Conveyor
- Opens/Closes Tank Doors
- Hydraulically Swings Conveyor

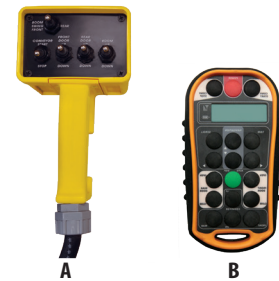

B) Optional Deluxe Wireless Remote

- Starts/Stops Conveyor
- Raises/Lowers Conveyor
- Opens/Closes Tank Doors
- Hydraulically Swings Conveyor
- Electronic Scale Shut-Off

C) WC3-D SpeedTender Scale & Wireless Control System

- Starts/Stops Conveyor
- Raises/Lowers Conveyor
- Opens/Closes Tank Doors
- Hydraulically Swings Conveyor
- Electronic Scale Shut-Off
- Remote Auto Dispense
- Remote Conveyor Speed Control
- Remote Talc Dispense
- Wireless Engine Start/Stop
- Opens/Closes Electric Roll Tarp
- Auto Bin Tracking





TENDING

To Your
Seed Needs

REDESIGNED FOR MAXIMUM SEED PROTECTION AND IMPROVED PERFORMANCE

The new J&M SpeedTender Pro™ 251 & 451 box tenders feature a gentle poly cup auger with patent pending “Bottom-Less Pit” design. This combination offers a more economical method to unload seed without sacrificing performance compared to tube belt conveyor designs.



INDUSTRY EXCLUSIVE “BOTTOM-LESS PIT” AUGER DESIGN

Significantly Minimize Seed Damage

The Bottom-less Pit auger minimizes seed damage by positioning the intake area above the bottom of the auger to create a safe zone for seed that may not be initially transported up the auger. This safe zone allows the seed to avoid the bottom of the auger where grinding and cracking occurs before moving up the auger to be unloaded. Through extensive testing, the intake area is precisely placed to minimize seed damage and rival the performance found with more expensive round tube belt conveyor designs.

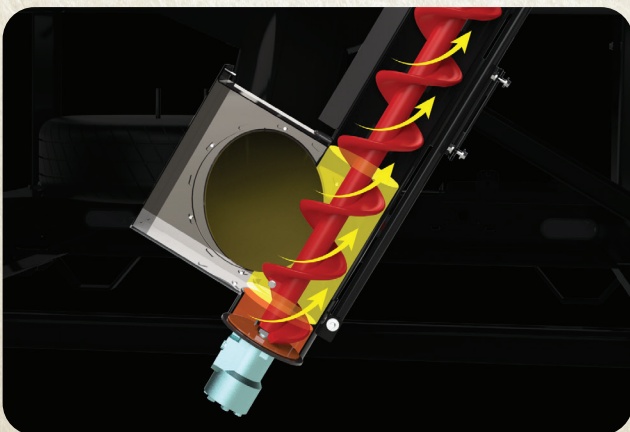

POLY-CUPPED AUGER

Efficient & Gentle

The poly-cup interior flighting is cup shaped to gently and quickly carry the seed up the auger. In addition, the outer tube and flighting diameters are correctly sized to prevent seed from getting caught against the tube and cracking.

ELECTRONIC WEIGH SYSTEM

Simple & Consistent

The controls and scales on J&M's 251 & 451 have been designed to keep things simple while still delivering consistent results when filling large bulk tanks or individual row boxes. All units with scales are automatically equipped with our “Auto Dispense” feature. Use “Auto Dispense” to easily disburse a precise amount of seed or use the “Split” feature to automatically divide your Pro Box into a specific number of rows with the push of a button. Both options keep it simple while delivering the consistent results you expect.

Auto Dispense - Timed/Weight Auto Dispense:

This feature allows you to accurately unload small and large amounts with auto dispense. If unloading an amount less than 200 lbs, a time-based approach is used to accurately dispense and evenly fill the individual rows. This time-based dispense unloads 20-199 lbs of seed and is accurate



LOW DECK HEIGHT

The J&M SpeedTender™ Pro 251 and 451 both feature a low deck height of 4'-2". The low profile deck height design gives the J&M SpeedTender Pro a superior center of gravity for safer transport. It also allows for easier loading and unloading of boxes by locating latches and locks in a convenient position.



within 2 lbs. When you unload 200 lbs or more, the traditional weight-based dispense is used. This feature is exclusive to J&M.

Split - To Automatically Divide a Single Pro Box to a Planter:

Split Dispense allows you to select the currently displayed weight or a manually entered custom weight and equally divide the seed to a specific number of rows. This allows you to easily and evenly divide an entire pro box. Split Dispense is easy to use. To activate Split Dispense, press the "Split" button, input your seed weight, press "Enter", input the number times you would like the seed to be divided (ie, number of planter boxes), and press "Enter". The system dispenses equal amounts for equally filled planter boxes. This feature is exclusive to J&M.



STANDARD FEATURES

- Auger Height (16'-9")
- 19 ft 3-Stage Telescoping Spout
- Poly-Cupped Plastic Auger Flighting
- Reversible Auger Switch For Complete Cleanout
- Low Deck Height (4'-2")
- Steep Chute Angle
- Two (2) 7,000 lbs Torsion Flex Axles (451 Models)
- Two (2) 5,200 lbs Torsion Flex Axles (251 Models)
- 13 hp Engine
- 4 Minute Per Box Flow Rate
- Powder Coated Exterior Finish
- Easy Access Cleanout Door
- Trouble Free Guide Plates
- Work Light For Night Time Unloading
- Auger Window For Cleanout Visibility

AVAILABLE OPTIONS



- Choice of Durable Red, Green, Blue, Tan or Black Powder Coat Finish
- Choice of Standard or Wireless Controls
- Choice of A-Frame, Gooseneck or Trailer Mount
- Electronic Weigh System
- 24 ft 3-Stage Telescoping Spout
- Talc Applicator

STANDARD & OPTIONAL CONTROLS

A) Standard All-Function Remote

Starts/Stops Auger
Raises/Lowers Auger

B) Optional Deluxe Wireless Remote

Starts/Stops Auger
Raises/Lowers Auger

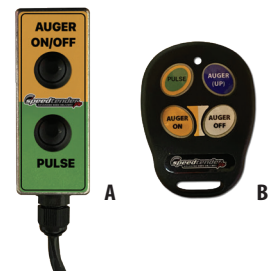

VARIABLE SPEED CONTROL

Available On Both Standard And Upgraded Controls

LC 290 | LC 390 | LC 535

EC 270

Seed Tender
Dimensions

	LC 290	LC 390	LC 535
A	5'-1" (A-Frame)	4'-9" (A-Frame)	-----
A	2'-10" (Gooseneck)	2'-8" (Gooseneck)	3'-6" (Gooseneck)
B	1'-6" (min) (A-Frame)	1'-6" (min) (A-Frame)	-----
B	2'-7" (min) (Gooseneck)	2'-7" (min) (Gooseneck)	2'-9" (min) (Gooseneck)
B	1'-10" (max) (A-Frame)	1'-10" (max) (A-Frame)	-----
B	3'-3" (max) (Gooseneck)	3'-3" (max) (Gooseneck)	3'-4" (max) (Gooseneck)
C	21'-3" (A-Frame)	22'-1" (A-Frame)	-----
C	23'-5" (Gooseneck)	24'-4" (Gooseneck)	29'-2" (Gooseneck)
D	9'-3"	9'-8"	10'-8"
E	3'-10"	3'-10"	4'-0"
F	17'-11"	17'-11"	20'-2"
G	8'-6"	8'-6"	8'-6"
H	16'-4" (max)	16'-4" (max)	17'-0" (max)
H	8'-7" (min)	8'-7" (min)	8'-7" (min)
I	17'-4" (max)	17'-4" (max)	20'-4" (max)
I	12'-10" (min)	12'-10" (min)	16'-2" (min)
J	9'-9"	10'-2"	11'-5"
K	11'-0"	11'-0"	11'-0"

	EC 270
A	2'-6" (A-Frame)
A	-0'-3" (Gooseneck)
B	1'-6" (min) (A-Frame)
B	2'-5" (min) (Gooseneck)
B	1'-10" (max) (A-Frame)
B	3'-1" (max) (Gooseneck)
C	20'-8" (A-Frame)
C	23'-3" (Gooseneck)
D	9'-4"
E	13'-0" (max)
E	7'-0" (min)
F	15'-0" (max)
F	12'-4" (min)
G	9'-10"
H	9'-5"

c4-50

	A-Frame	Gooseneck	Trailer Mount
A	4'-10"	2'-10"	12'-9"
B	1'-6" (min)	2'-7" (min)	NA
B	1'-10" (max)	3'-3" (max)	NA
C	20'-4"	22'-6"	12'-5"
D	11'-3"	11'-3"	10'-8"
E	8'-6"	8'-6"	8'-6"
F	14'-2" (max)	14'-2" (max)	14'-2" (max)
F	8'-7" (min)	8'-7" (min)	8'-7" (min)
G	16'-5" (max)	16'-5" (max)	16'-5" (max)
G	13'-7" (min)	13'-7" (min)	13'-7" (min)

251 | 451

	Pro 251	Pro 451
A	16'-4"	16'-4"
B	21'-3"	21'-3"
C	4'-111/2"	4'-111/2"
D	4'-2"	4'-2"
E	8'-4"	8'-4"
F	9'-3"	9'-3"
G	12'-1"	12'-1"
H	13'-0"	16'-10"



Seed Tender
Specifications

	Capacity (total)**	Weight (empty)	Tongue Wt. (loaded)	Conveyor/Auger	Unloading Rate	Conveyor/Auger Reach	Axles	Engine
EC 270	270 Cubic Feet	4,400 lbs.	1,086 lbs.	19' Long 7" Diameter	16 Bushels/Min	44' (front to rear swing)	Two (2), 7,000 lb. Torsion-Flex Axles w/Electric Brakes	4.8 hp Honda Motor w/Electric Start
LC 290	290 Seed Units 290 Cubic Feet	6,100 lbs.	1,650 lbs. 1,207 lbs. (Gooseneck)	22' Long, 8" Tube Conveyor	30 Bushels/Min	49' (front to rear swing)	Two (2), 7,000 lb. Torsion-Flex Axles w/Electric Brakes	13 hp Motor w/Electric Start
LC 390	390 Seed Units 390 Cubic Feet	7,500 lbs.	1,380 lbs. 1,453 lbs. (Gooseneck)	22' Long, 8" Tube Conveyor	30 Bushels/Min	49' (front to rear swing)	Three (3), 7,000 lb. Torsion-Flex Axles w/Electric Brakes	13 hp Motor w/Electric Start
LC 390ST-2AS							Two (2), 10,000 lb. Axles w/Electric Brakes	
LC 535	535 Seed Units 535 Cubic Feet	11,000 lbs.	4,900 lbs.	24.5' Long, 10" Tube Conveyor	45 Bushels/Min	50' (front to rear swing) (w/telescoping spout)	Two (2), 16,000 lb. Dual Wheel, Spring Ride w/Electric Brakes	13 hp Motor w/Electric Start
Pro C4-50	Four (4), 50 Unit Boxes	6,300 lbs.	1,650 lbs.	22' Long, 8" Tube Conveyor	30 Bushels/Min	49' (front to rear swing)	Two (2), 7,000 lb. Torsion-Flex Axles w/Electric Brakes	13 hp Motor w/Electric Start
Pro 251	Two (2), 50 Unit Boxes	2,850 lbs.	650 lbs.	16' Spout Height	4-Minutes per Box	42' (w/optional 24' spout)	Two (2), 5,200 lb. Torsion-Flex Axles w/Electric Brakes	13 hp Motor w/Electric Start
Pro 451	Four (4), 50 Unit Boxes	3,786 lbs.	1,400 lbs.	16' Spout Height	4-Minutes per Box	42' (w/optional 24' spout)	Two (2), 7,000 lb. Torsion-Flex Axles w/Electric Brakes	13 hp Motor w/Electric Start

*Specifications and dimensions are subject to change without notice or obligation.

**Measured with soybeans at 140,000 seeds per unit weighing 45 lbs.

MODEL EC 270

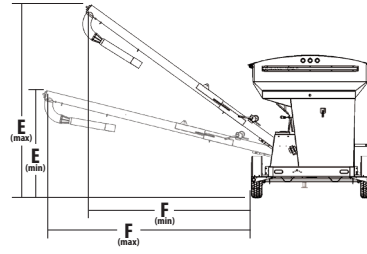
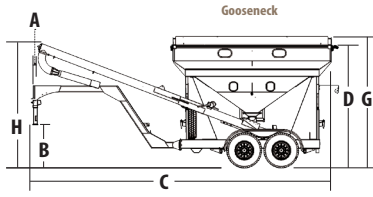
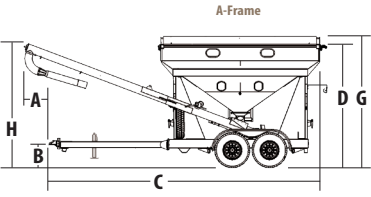

MODEL LC 290

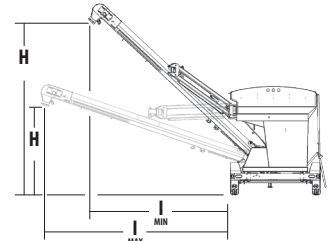
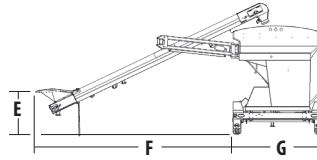
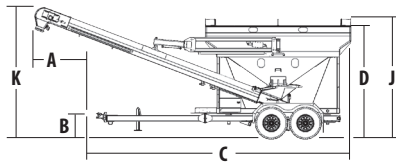
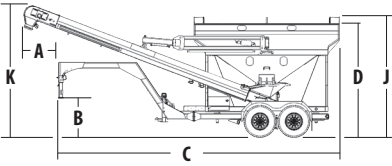

MODEL LC 390

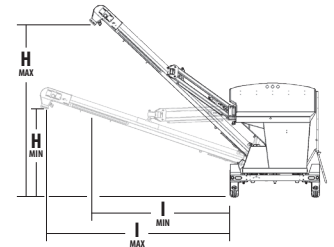
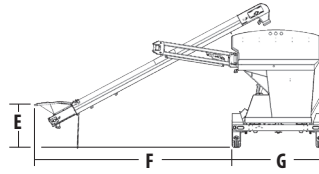
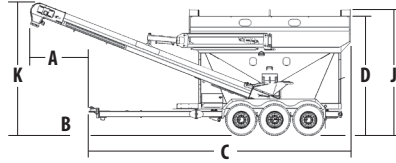
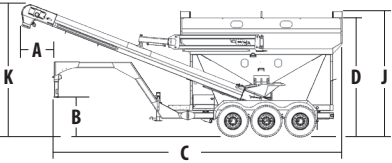

MODEL LC 535

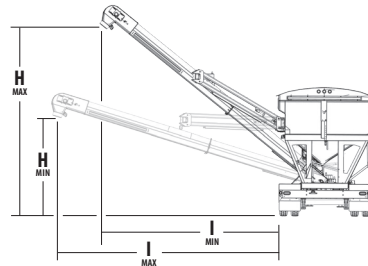
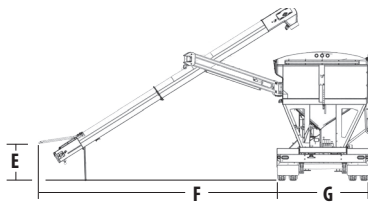
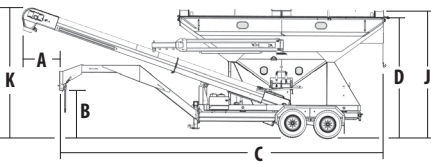

MODEL C4-50

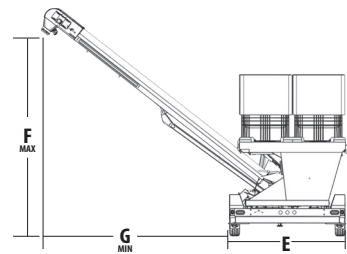
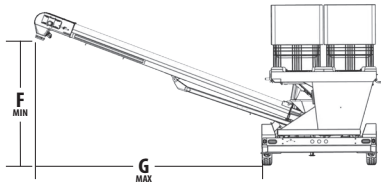
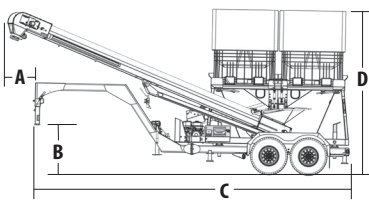

MODEL 451 | 251

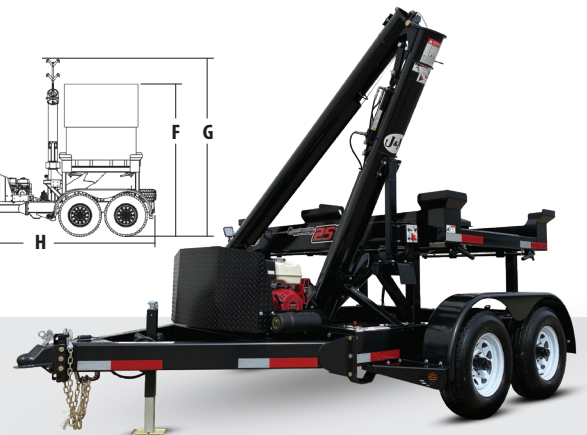
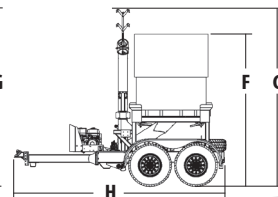
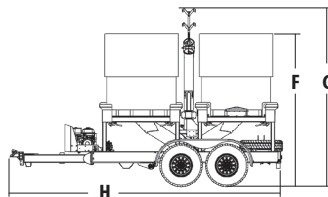
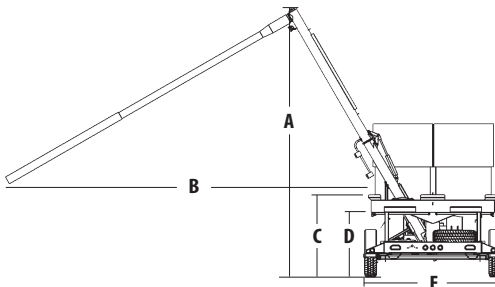



J&M Manufacturing
Premium Seed Tenders



speedtender

ADVANCED SEED DELIVERY



GUARANTEE

J & M MANUFACTURING CO guarantees against any faulty construction or materials for a period of ONE year. We reserve the right to inspect and decide whether material or construction was faulty or whether abuse or accident voids our guarantee.

Specifications are subject to change without notice or obligation.

*Registered Trademark of J. & M. Mfg., Co. Inc.