

OPERATORS MANUAL

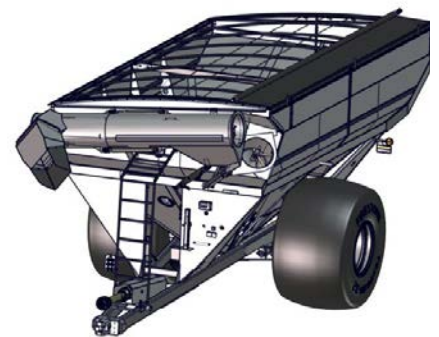

1050-20
1051-22
1150-20
1151-22

GRAIN CART



Rev. 7.15.2024

J. & M. Mfg. Co., Inc.
284 Railroad Street - P.O. Box 547
Fort Recovery, OH 45846
Ph: (419) 375-2376 Fax: (419) 375-2708
www.jm-inc.com

To The Dealer

Read manual instructions and safety rules. Make sure all items on the Dealer's Pre-Delivery and Delivery Check Lists are completed before releasing equipment to the owner.

The dealer must complete the Warranty Registration found on the Dealer Portal website located at dealer.jm-inc.com. and return it to J&M Mfg. Co., Inc. at the address indicated on the form. Warranty claims will be denied if the Warranty Registration has not been submitted.

EXPRESS WARRANTY:

J&M Mfg. Co., Inc. warrants against defects in construction or materials for a period of ONE year. We reserve the right to inspect and decide whether material or construction was faulty or whether abuse or accident voids our guarantee.

Warranty service must be performed by a dealer or service center authorized by J&M Mfg. Co., Inc. to sell and/or service the type of product involved, which will use only new or remanufactured parts or components furnished by J&M Mfg. Co., Inc. Warranty service will be performed without charge to the purchaser for parts or labor based on the Warranty Labor Times schedule. Under no circumstance will allowable labor times extend beyond the maximum hours indicated in the Warranty Labor Times schedule for each warranty procedure. The purchaser will be responsible, however, for any service call and/or transportation of the product to and from the dealer or service center's place of business, for any premium charged for overtime labor requested by the purchaser, and for any service and/or maintenance not directly related to any defect covered under the warranty. Costs associated with equipment rental, product down time, or product disposal are not warrantable and will not be accepted under any circumstance.

Each Warranty term begins on the date of product delivery to the purchaser. Under no circumstance will warranty be approved unless (i) the product warranty registration card has been properly completed and submitted to the equipment manufacturer, and (ii) a warranty authorization number has been issued by the equipment manufacturer. This Warranty is effective only if the warranty registration card is returned within 30 days of purchase.

This Warranty does not cover a component which fails, malfunctions or is damaged as a result of (i) improper modification or repair, (ii) accident, abuse or improper use, (iii) improper or insufficient maintenance, or (iv) normal wear or tear. This Warranty does not cover products that are previously owned and extends solely to the original purchaser of the product. Should the original purchaser sell or otherwise transfer this product to a third party, this Warranty does not transfer to the third party purchaser in any way. J&M Mfg. Co., Inc. makes no Warranty, express or implied, with respect to tires or other parts or accessories not manufactured by J&M Mfg. Co., Inc. Warranties for these items, if any, are provided separately by their respective manufacturers.

THIS WARRANTY IS EXPRESSLY IN LIEU OF ALL OTHER WARRANTIES OR CONDITIONS, EXPRESS, IMPLIED OR STATUTORY, INCLUDING ANY IMPLIED WARRANTY OF MERCHANTABILITY OR FITNESS FOR PARTICULAR PURPOSE.

In no event shall J&M Mfg. Co., Inc. be liable for special, direct, incidental or consequential damages of any kind. The exclusive remedy under this Warranty shall be repair or replacement of the defective component at J&M Mfg. Co., Inc.'s option. This is the entire agreement between J&M Mfg. Co., Inc. and the Owner about warranty and no J&M Mfg. Co., Inc. employee or dealer is authorized to make any additional warranty on behalf of J&M Mfg. Co., Inc.

The manufacturer reserves the right to make product design and material changes at any time without notice. They shall not incur any obligation or liability to incorporate such changes and improvements in products previously sold to any customer, nor shall they be obligated or liable for the replacement of previously sold products with products or parts incorporating such changes.

SERVICE:

The equipment you have purchased has been carefully manufactured to provide dependable and satisfactory use. Like all mechanical products, it will require cleaning and maintenance. Lubricate the unit as specified. Observe all safety information in this manual and safety signs on the equipment.

For service, your authorized J&M dealer has trained mechanics, genuine J&M service parts, and the necessary tools and equipment to handle all your needs.

Use only genuine J&M service parts. Substitute parts may void warranty and may not meet standards required for safety and satisfactory operation. Record the model number and serial number of your equipment in the spaces provided:

Model No: _____ **Serial No:** _____ **Date of Purchase:** _____

Purchased From: _____

Provide this information to your dealer to obtain correct repair parts.

General Information

TO THE OWNER:

The purpose of this manual is to assist you in operating and maintaining your grain cart in a safe manner. Read it carefully. It furnishes information and instructions that will help you achieve years of dependable performance and help maintain safe operating conditions. If this machine is used by an employee or is loaned or rented, make certain that the operator(s), prior to operating:

1. Is instructed in safe and proper use.
2. Reviews and understands the manual(s) pertaining to this machine.

Throughout this manual, the term **IMPORTANT** is used to indicate that failure to observe can cause damage to equipment. The terms **CAUTION**, **WARNING** and **DANGER** are used in conjunction with the Safety-Alert Symbol (a triangle with an exclamation mark) to indicate the degree of hazard for items of personal safety. When you see this symbol, carefully read the message that follows and be alert to the possibility of personal injury or death.

⚠ This Safety-Alert symbol indicates a hazard and means **ATTENTION! BECOME ALERT! YOUR SAFETY IS INVOLVED!**

⚠ DANGER Indicates an imminently hazardous situation that, if not avoided, will result in death or serious injury.

⚠ WARNING Indicates a potentially hazardous situation that, if not avoided, will result in death or serious injury, and includes hazards that are exposed when guards are removed.

⚠ CAUTION Indicates a potentially hazardous situation that, if not avoided, may result in minor or moderate injury.

IMPORTANT Indicates that failure to observe can cause damage to equipment.

NOTE Indicates helpful information.

Specifications

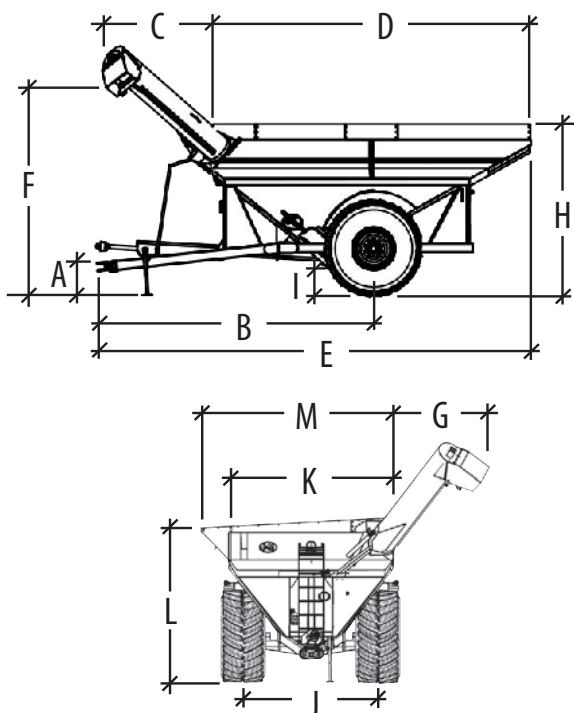

SPECIFICATIONS

	1050/1051	1150/1151
Capacity	1,050 Bushels	1,150 Bushels
Auger, One Vertical	20" or 22" Diameter	20" or 22" Diameter
Unload Time	2.1 or 1.7 minutes	2.3 or 1.9 minutes
Wheels (2)	27x32HD, 31x32 32x36 or 44x32	27x32 HD or 44x32
Spindles (2)	6" Diameter	6" Diameter
PTO	1,000 rpm	1,000 rpm
Tires (2)	900/60R32, 35.5x32, 1050/50R32 or 1250/50R32	900/60R32, 1050/50R32 or 1250/50R32
Tongue Weight		
Empty	2,900 lbs.	2,900 lbs.
Loaded	4,200 lbs.	4,200 lbs.
Total Weight (approx.)	13,100 lbs.	13,500 lbs.

DIMENSIONS

Model	A	B	C	D	E	F	G	H	I	J	K	L	M
1050	1'-6"	18'-10"	8'-6"	22'-0"	29'-7"	13'-4"	6'-4"	12'-0"	1'-5"	9'-6"	11'-9"	10'-11"	N/A
1051						14'-2"	7'-6"			10'-0"			
1150	1'-6"	18'-10"	8'-6"	22'-0"	29'-7"	13'-4"	6'-4"	12'-0"	1'-5"	9'-6"	11'-9"	11'-7"	N/A
1151						14'-2"	7'-6"			10'-0"			

Specifications

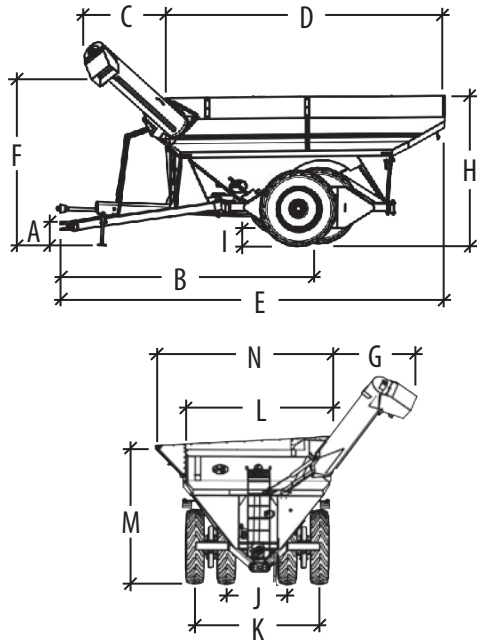

WALKING TANDEM DUAL WHEELS SPECIFICATIONS

	1050 (20" Auger)	1150 (20" Auger)
	1051 (22" Auger)	1151 (22" Auger)
Capacity	1,050 Bushels	1,150 Bushels
Auger, One Vertical	20" or 22" Diameter	20" or 22" Diameter
Unload Time	2.1 or 1.7 minutes	2.3 or 1.9 minutes
Wheels (4)	16x42, 18 x 38, 18x42	16x42, 18 x 38, 18x42
Spindles (4)	4 1/2" Diameter	4 1/2" Diameter
Tires (4)	480/80R42, 520/85R38, or 520/85R42	480/80R42, 520/85R38, or 520/85R42
Tongue Weight		
Empty	2,900 lbs.	2,900 lbs.
Loaded	4,200 lbs.	4,200 lbs.
Total Weight (approx.)	16,100 lbs.	16,500 lbs.

DIMENSIONS

Model	A	B	C	D	E	F	G	H	I	J	K	L	M
1050	1'-6"	18'-10"	8'-6"	22'-0"	29'-7"	13'-4"	6'-4"	12'-0"	1'-5"	5'-0"	11'-9"	10'-11"	10'-11"
1051						14'-2"	7'-6"			6'-0"			
1150	1'-6"	18'-10"	8'-6"	22'-0"	29'-7"	13'-4"	6'-4"	12'-2"	1'-5"	5'-0"	11'-9"	11'-7"	11'-7"
1151						14'-2"	7'-6"			6'-0"			

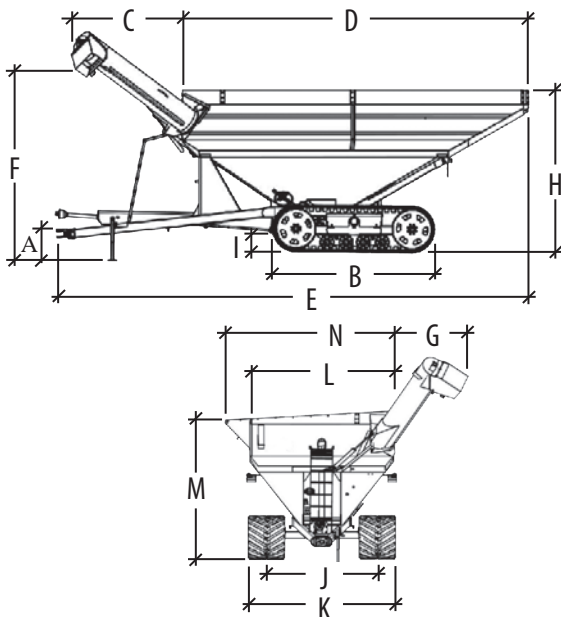

STORM TRACKER TRACK SYSTEM SPECIFICATIONS

	1050 (20" Auger)	1150 (20" Auger)
	1051 (22" Auger)	1151 (22" Auger)
Capacity	1,050 Bushels	1,150 Bushels
Auger, One Vertical	20" or 22" Diameter	20" or 22" Diameter
Unload Time	2.1 or 1.7 minutes	2.3 or 1.9 minutes
Tongue Weight		
Empty	2,900 lbs.	2,900 lbs.
Loaded	4,200 lbs.	4,200 lbs.
Total Weight (approx.)	21,300 lbs.	21,700 lbs.
Compaction Rate (Ground Pressure)	9.93 lbs/sq inch	10.67 lbs/sq inch

DIMENSIONS

Model	A	B	C	D	E	F	G	H	I	J	K	L	M
1050	1'-6"	12'-2"	8'-6"	22'-0"	29'-7"	13'-4"	6'-4"	12'-0"	1'-5"	9'-0"	12'-0"	11'-9"	10'-11"
1051						14'-2"	7'-6"						
1150	1'-6"	12'-2"	8'-6"	22'-0"	29'-7"	13'-4"	6'-4"	12'-0"	1'-5"	9'-0"	12'-0"	11'-9"	11'-7"
1151						14'-2"	7'-6"						

General Information

BOLT TORQUE CHART

Always tighten hardware to these values unless a different torque or tightening procedure is listed for specific application.

Fasteners must always be replaced with the same grade as specified in the manual parts list.

Always use the proper tool for tightening hardware: SAE for SAE hardware and Metric for Metric hardware.

Make sure fastener threads are clean and you start thread engagement properly.

All torque values are given to specifications used on hardware defined by SAE J1701 & J1701M (JUL 96)

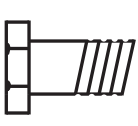

SAE SERIES TORQUE CHART



SAE Grade 2
(No Dashes)

SAE Bolt Head
Identification



SAE Grade 5
3 Radial Dashes



SAE Grade 8
6 Radial Dashes

Diameter (Inches)	Wrench Size	MARKING ON HEAD					
		SAE 2		SAE 5		SAE 8	
		LBS.-FT.	N-m	LBS.-FT.	N-m	LBS.-FT.	N-m
1/4	7/16"	6	8	10	13	14	18
5/16	1/2"	12	17	19	26	27	37
3/8	9/16"	23	31	35	47	49	67
7/16	5/8"	36	48	55	75	78	106
1/2	3/4"	55	75	85	115	120	163
9/16	13/16"	78	106	121	164	171	232
5/8	15/16"	110	149	170	230	240	325
3/4	1-1/8"	192	261	297	403	420	569
7/8	1-5/16"	306	416	474	642	669	907
1	1-1/2"	467	634	722	979	1020	1383

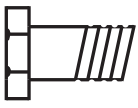

METRIC SERIES TORQUE CHART



Metric
Grade 8.8

Metric Bolt Head
Identification



Metric
Grade 10.9

Diameter & (Millimeters) Thread Pitch	Wrench Size	COARSE THREAD				FINE THREAD				Diameter & (Millimeters) Thread Pitch
		MARKING ON THREAD				MARKING ON THREAD				
		Metric 8.8		Metric 10.9		Metric 8.8		Metric 10.9		
6 x 1.0	10 mm	8	6	11	8	8	6	11	8	6 x 1.0
8 x 1.25	13 mm	20	15	27	20	21	16	29	22	8 x 1.0
10 x 1.5	16 mm	39	29	54	40	41	30	57	42	10 x 1.25
12.1.75	18 mm	68	50	94	70	75	55	103	76	12.1.25
14 x 2.0	21 mm	109	80	151	111	118	87	163	120	14 x 1.5
16 x 2.0	24 mm	169	125	234	173	181	133	250	184	16 x 1.5
18 x 2.5	27 mm	234	172	323	239	263	194	363	268	18 x 1.5
20 x 2.5	30 mm	330	244	457	337	367	270	507	374	20 x 1.5
22 x 2.5	34 mm	451	332	623	460	495	365	684	505	22 x 1.5
24 x 3.0	36 mm	571	421	790	583	623	459	861	635	24 x 2.0
30 x 3.0	46 mm	1175	867	1626	1199	1258	928	1740	1283	30 x 2.0

TIGHTENING WHEEL NUTS

Standard 3/4" wheel studs and nuts should be tightened to torque 500 Ft.-Lbs and standard 22mm studs should be tightened to torque 700 Ft.-Lbs. During initial operation of the grain cart and then checked for proper torque after every 10 hours of use. Failure to do so may damage wheel nut seats. Once seats are damaged, it will become impossible to keep nuts tight.

Table of Contents

2	To The Dealer
3-4.....	Specifications
5	Bolt Torque Chart
7-8.....	Safety Rules
9	Initial Operation and Maintenance
10-11.....	Operating Instructions
12	Lubrication Schedule
13	Troubleshooting
14	Adjusting the Slip Clutch
15	Adjusting the Flighting
16-36.....	Repair Parts

Safety Rules



ATTENTION! BECOME ALERT! YOUR SAFETY IS INVOLVED!



Safety is a primary concern in the design and manufacture of our products. Unfortunately, our efforts to provide safe equipment can be erased by an operator's single careless act. In addition, hazard control and accident prevention are dependent upon the awareness, concern, judgment, and proper training of personnel involved in the operation, transport, maintenance and storage of equipment.

Make certain that the operator(s), prior to operating is instructed in safe and proper use and reviews and understands the manual(s) pertaining to this machine. Also make certain that the operator(s) reviews and understands the operator's manual of the tractor prior to hooking up or operating the grain cart.

Read this manual before you operate this machine. If you do not understand any part of this manual, or need more information, contact the manufacturer or your authorized dealer.

SAFETY

Understand that your safety and the safety of other persons is measured by how you service and operate this machine. Know the positions and functions of all controls before you try to operate them. Make sure to check all controls in a safe area before starting your work.

The safety information given in this manual does not replace safety codes, federal, state or local laws. Make certain your machine has the proper equipment as designated by local laws and regulations.

A frequent cause of personal injury or death is from persons falling off equipment and being run over. Do not permit persons to ride on this machine.

Travel speeds should be such that complete control and machine stability is maintained at all times. Where possible, avoid operating near ditches, embankments and holes. Reduce speed when turning, crossing slopes and rough, slick or muddy surfaces.

Collision of high speed road traffic and slow moving machines can cause personal injury or death. On roads, use flasher lights according to local laws. Keep slow-moving-vehicle emblem visible. Pull over to let faster traffic pass.

Hydraulic oil leaking under pressure can penetrate skin and cause infection or other injury. To prevent personal injury,

- Relieve all pressure, before disconnecting fluid lines,
- Before applying pressure, make sure all connections are tight and components are in good condition,
- Never use your hand to check for suspected leaks under pressure. Use a piece of cardboard or wood for this purpose.
- If injured by leaking fluid, see your doctor immediately.

When transporting the grain cart, always keep the auger in the stow position.

Use care when moving or operating the grain cart near electric lines, as serious injury or death can result from contact.

Never adjust, service, clean, or lubricate the grain cart until all power is shut off. Keep all safety shields in place. Keep hands, feet, hair and clothing away from moving parts while the grain cart is in operation.

The service ladder is for service work only. If you must climb into the grain tank, be certain that all power is shut off and then use extreme caution when climbing into the grain cart.

Make sure that everyone is clear of equipment before applying power or moving the machine.

Make sure that the grain cart is fastened securely to the tractor by using a high strength hitch pin, clip and safety chains. Make sure that the grain cart hitch properly matches the hitch type of the tractor. Use a single prong (spade) grain cart hitch with a double prong (clevis) tractor hitch. Use a double prong (clevis) grain cart hitch with a single prong (spade) tractor hitch.

Before filling the grain cart, make certain that no one is inside the grain tank. Never allow children or anyone in, near, or on the grain cart during transport or during loading and unloading of grain. Be aware that moving grain is dangerous and can cause entrapment, resulting in severe injury or death by suffocation.

Never operate the auger system with anyone inside the grain tank. Hands, feet, hair and clothing can fit through the openings in and around the grate. Contact with the auger can cause severe injury or death. Make certain that all power is shut off before service work is performed.

Before unhooking the grain cart from the tractor, be sure the jack stand is properly mounted and in place and the wheels are properly blocked to prevent the cart from moving.

Safety Rules

⚠ ATTENTION! BECOME ALERT! YOUR SAFETY IS INVOLVED! ⚠

Replace Immediately If Damaged or Missing

IMPORTANT: Install new safety signs if the old signs are destroyed, lost, painted over or cannot be read. When parts are replaced that have safety signs, make sure you install a new sign with each new part. New signs are available from the manufacturer or your authorized dealer.

#	Part #	Description
1	JM0018044	Operating Instructions
2	JM0010163	Warning, High Pressure
3	JM0014979	Warning, General
4	JM0018039	Warning, Keep Hands Away
5	JM0010150	Warning, Lug Nuts
6	JM0018035	Danger, Keep Hands Away
7	JM0018034	Danger, Keep Off Ladder
8	JM0015099	Danger, Electric Lines
9	JM0018033	Danger, Do Not Enter Tank
10	JM0018037	Danger, Suffocation
11	JM0018036	Danger, Rotating Driveline
12	JM0018038	Farm Use Only
13	JM0025433	Open
14	JM0025434	Closed
15	JM0025435	Check PTO Overlap
16	JM0018043	Warning, Check Lug Nuts
17	JM0015151	J&M Oval Decal, Large
18	JM0010179	J&M Oval Decal, Medium
19	Specify	OAS Black Fade Stripe
20	Specify	AS Black Fade Stripe

IMPORTANT

OPERATING INSTRUCTIONS

- 1) With the gate indicator in the closed position, fill the box with grain.
- 2) With the PTO disengaged, fold the discharge auger to the upright position.
- 3) After the auger is in the upright position, start the PTO at a SLOW RATE OF SPEED until the pin on the upper auger engages the drive dog on the bottom auger (failure to follow this procedure may cause extensive damage to both the drive dog and the pin).
- 4) Increase PTO to the maximum r.p.m. speed and slowly open the inner gate until the position is in the halfway position. When grain begins flowing from the discharge auger, adjust the gate to control the rate of flow (Do not slow the speed of the PTO).
- 5) To stop unloading, FIRST return the inner gate to the closed position. For complete clean-out, gradually close the gate. Allow the unloading auger to clean-out before disengaging the PTO. Disengage the PTO and allow the auger to come to a complete stop. Fold the upper auger to the stow position.

ENG-101

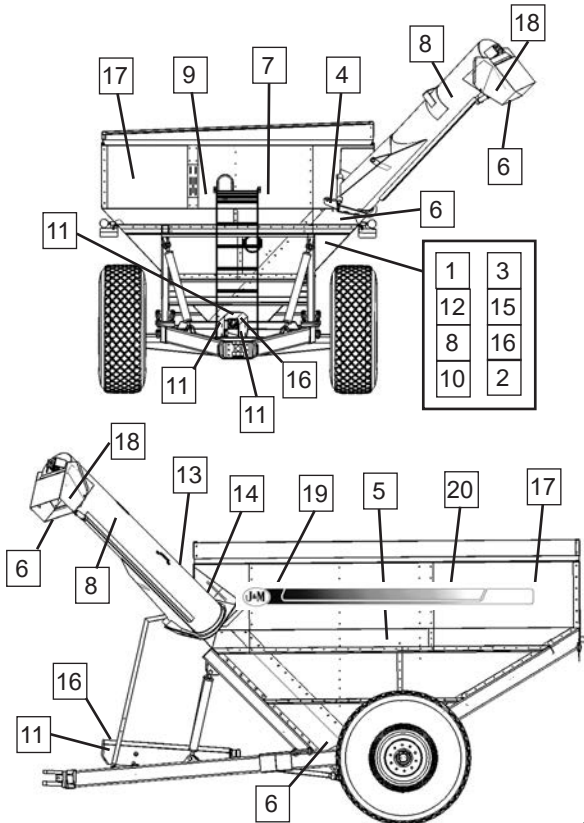

⚠ WARNING

HIGH PRESSURE FLUID HAZARD

- To prevent serious injury or death:
- Relieve pressure on system before repairing or adjusting or disconnecting
- Wear proper hand and eye protection when searching for leaks. Use wood or cardboard instead of hands.
- Keep all components in good repair.

ENG-102

⚠ WARNING

- DO NOT ADJUST, SERVICE, CLEAN OR LUBRICATE THE MACHINE UNTIL ALL POWER IS SHUT OFF.
- KEEP ALL SAFETY SHIELDS IN PLACE.
- KEEP PEOPLE AND OBJECTS CLEAR OF EQUIPMENT BEFORE APPLYING POWER OR MOVING THE MACHINE.
- PREVENT PEOPLE FROM RIDING ON THE MACHINE. FALLING CAN CAUSE SERIOUS INJURY OR DEATH.
- BEFORE HIGHWAY TRAVEL, SECURE A SLOW-MOVING VEHICLE EMBLEM TO THE REAR OF THE MACHINE. MAKE SURE ALL FLASHER, TURN INDICATOR AND BRAKE LIGHTS ARE WORKING PROPERLY BEFORE HIGHWAY TRAVEL.

ENG-103

FOR FARM USE ONLY

ENG-112



ENG-117



ENG-118



ENG-113



ENG-114

CHECK PTO OVERLAP

CHECK MANUAL FOR PTO LENGTH. INCORRECT PTO OVERLAP MAY CAUSE EXTENSIVE DAMAGE TO DRIVE SYSTEM.

ENG-115

CHECK ALL WHEEL NUTS

DEALER OR MANUFACTURER IS NOT RESPONSIBLE FOR DAMAGE CAUSED BY LOOSE WHEEL NUTS.

ENG-116

⚠ WARNING

KEEP HANDS, FEET, HAIR AND CLOTHING AWAY FROM MOVING PARTS

ENG-104

⚠ WARNING

KEEP LUG NUTS TIGHTENED

ENG-105

⚠ DANGER

FLOWING GRAIN TRAPS AND SUFFOCATES VICTIMS IN SECONDS!

NEVER PLAY IN OR ON GRAIN CART

YOU CAN DIE IN SECONDS IN FLOWING GRAIN!

ENG-110

⚠ DANGER

ROTATING DRIVELINE CONTACT CAN CAUSE DEATH. KEEP AWAY!

- Keep all guards in place when operating.
- Do NOT stand on steps or climb ladder until all power is shut off.
- Keep hands, feet, hair and clothing away from moving parts.

ENG-111

⚠ DANGER

DO NOT ENTER GRAIN TANK WHEN AUGER IS RUNNING.

ENG-109

⚠ DANGER

SERIOUS INJURY OR DEATH CAN RESULT FROM CONTACT WITH ELECTRIC LINES. USE CARE WHEN MOVING OR OPERATING THIS MACHINE NEAR ELECTRIC LINES TO AVOID CONTACT.

ENG-108

⚠ DANGER

KEEP OFF THE LADDER WHILE THE MACHINE IS OPERATING. IN TRANSPORT OR THE UNLOADING AUGER IS IN MOTION

ENG-107

⚠ DANGER

KEEP HANDS AND CLOTHING AWAY FROM MOVING PARTS

ENG-106

Initial Operation and Maintenance

WARNING

BE CERTAIN THAT ALL POWER IS SHUT OFF BEFORE SERVICING THE GRAIN CART.

Before the grain cart is put into service:

Have the safety instructions been read and clearly understood by the operator(s) of this machine?

Has the gearbox been properly filled with EP-80-90 gearbox lubricant?

Have all nuts, bolts, bearings and braces been properly fastened?

Has the PTO been checked for proper overlap?

IMPORTANT: Has the slip clutch on the PTO been serviced? If the slip clutch is left unchecked, damages to the power-take-off and drive shaft may result. Before using the grain cart, loosen the bolts around the slip clutch. Make sure the friction plates turn free of each other and are not corroded together. Re-tighten the tension bolts. Run the auger system EMPTY and check for proper engagement of the slip clutch.

CHECK PTO OVERLAP LENGTH. Overlap length may vary depending on the tractor model and hitch setting. Try to obtain the greatest possible overlap without bottoming out in the extreme operating conditions. Too much overlap may cause the PTO to bottom out and damage the driveline. Not enough overlap may cause the PTO front and back halves to separate. From the fully compressed (shortest) length the PTO should be telescoped (extended) between 10" and 22". Different PTO lengths may need to be purchased to accommodate your terrain. A 4" shorter or a 10" longer PTO can be ordered through your dealer from J&M Manufacturing.

GREASE BEARINGS: Are all bearings on the drive line properly greased? Are all set screws in the bearings and U-joints tight? Has the power-take-off shaft been properly greased at all points including the cross bearings? Has the universal joint at the gearbox been greased? Have all grease points at the auger hinge area, including the hanger bushing assembly been greased?

TIRE PRESSURE: Are the tires properly inflated? The following is to be used as a **general guide** for tire inflation for cyclic use. Figures can vary depending on specific brand of tire used. **It is important that tires are inspected before and after the unit is loaded. The tire should stand up with no side wall buckling or distress as the tire rolls. Do Not Exceed The Tire Pressure Indicated Below:**

Tire Size	psi
900/60R32-R1-2	41
900/60R32-R1-2A	66
900/60R32-R1-2-193	57
35.5 x 32-R3-2	26
1050/50R32-R1-2	56
1250/50R32-R1-2-188	46
480/80R42-4	29
520/85R38-4	29
520/85R42-4	44

Operating Instructions

WHEEL NUTS: Are the wheel nuts properly fastened? **Torque to 700 Lbs.-Ft. for standard 22mm wheel studs and nuts. Torque to 500 Lbs.-Ft. for 3/4" wheel studs and nuts. Wheel studs and nuts should be checked after each load during initial operation of the cart and then after every 10 hours of use. Failure to do so may damage wheel studs and nuts.** Once the seats are damaged, it will become impossible to keep the lug nuts tight.

The drawing shows the proper way to mount the wheels using Budd-type nuts. The wheels supplied with your grain cart have straight holes and the Budd nuts will be mounted according to Figure 1. Wheels that are improperly installed on the grain cart, resulting in product failure, will nullify warranty and shift the burden of liability to the owner/operator. **We recommend you inspect your wheel nuts to make sure they are properly installed. Also, check the wheel nuts on a regular basis to ensure they are tight.**

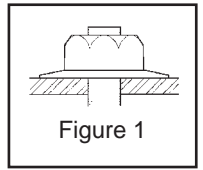

LIGHTING AND SAFETY DECALS: Are the rear, amber extremity lights properly positioned? Extend the lights within 16" (40,6cm) of the left and right extremities of the grain cart. Is an SMV Emblem attached to the rear of the grain cart?

Are the lights working properly? Are all lights and reflective decals clean, visible and properly placed?

⚠️ WARNING

BE CERTAIN THAT ALL POWER IS SHUT OFF WHEN HOOKING UP TO TRACTOR OR CONNECTING HYDRAULIC LINES TO TRACTOR.

Preparing the Grain Cart for Use: Models 1050 & 1051 requires a 225+ hp tractor or larger.

IMPORTANT: Do NOT pull a loaded grain cart on highway. For incidental highway travel, observe the section below.

Tow Loads Safely

Stopping distance increases with speed and weight of towed loads and on slopes. Towed loads with or without brakes that are too heavy for the tractor or are towed too fast, can cause loss of control. Consider the total weight of the equipment and its load.

Observe these recommended maximum road speeds, or local speed limits, which may be lower.

Road Travel (grain cart empty): Do not travel more than 32 km/hr (20 mph) and do not tow loads more than 1.5 times the pulling unit's weight.

Ensure the load does not exceed the recommended weight ratio. Use additional caution when towing loads under adverse surface conditions, when turning, and on inclines.

⚠️ WARNING: For greater stability on uneven or steep terrain, position non-scale wheel spindles at the furthest out setting.

IMPORTANT:

1) Connect grain cart hitch to tractor drawbar using a good quality hitch pin. Attach the safety chain to the tractor and around the A-frame of the cart as shown. Make sure the grain cart hitch properly matches the hitch of the tractor. Use a single prong (spade) grain cart hitch with a tractor double prong (clevis) hitch. Use a double prong (clevis) grain cart hitch with a single prong (spade) tractor hitch.

Safety Chain User Instruction

- Secure the safety chain by looping it around the each side of the grain cart as shown and connecting to the towing machine's attaching bar.
- Do Not allow any more slack than necessary for articulation (maximum 11 inches)
- Do Not use any intermediate support as the attaching point.
- Store the safety chain by securing it around the main axle A-frame of the grain cart.
- Replace the safety chain if one or more links or end fittings are broken, stretched or otherwise damaged or deformed.



2) Attach the power-take-off shaft to the tractor. The PTO must have at least 10" of engagement. Check tractor drawbar for clearance and length and adjust if necessary. **Make sure the PTO does not bottom out when making sharp turns as it may bend the drive shaft.**

3) Make sure the jack stand is removed from the lower support position before the cart is moved. **Never use the jack to support a loaded grain cart.**

Operating Instructions (Continued)

- 4) Be sure that no debris or foreign objects are in the grain cart.
- 5) Attach the hydraulic lines to the tractor. Two hydraulic lines (green band) operate the inside gate mechanism. Connect these lines to one service outlet on the tractor. Two hydraulic lines (yellow band) operate the folding mechanism of the auger. Connect these lines to a second service outlet on the tractor. The remaining two hydraulic lines (red band) operate the hydraulic flow control spout located at the end of the upper auger. Connect these lines to a third service outlet on the tractor. Make sure the air is bled from the hydraulic cylinders and hoses.
- 6) Run the auger system EMPTY before loading grain into the tank for actual use. Make certain that the slip clutch is operating and that the upper and lower augers are properly engaged.
- 7) Connect the lighting 7-prong connector end on the main wiring harness to the tractor electrical outlet. Make sure that all flasher and turn indicator lights are working properly before incidental highway travel.

CAUTION

- Do NOT operate the grain cart before reading and understanding the Operator's Manual and ALL danger, warning and caution signs.
- Be sure that a Slow-Moving-Vehicle emblem is attached to the rear of the grain cart.
- Never exceed 1,000 rpm on the PTO and driveline system.
- Never fold or extend the auger until the PTO has come to a complete stop.
- Never fill the grain cart unless the gate indicator is in the closed position.
- Never allow foreign objects (shovels, etc.) to be placed inside the grain cart.
- Never engage the lugs and drive dogs on the augers when the system is moving at a high rate of speed.
- Never perform maintenance work or service the grain cart with the tractor running.

Loading and Unloading the Grain Cart

- 1) With the gate indicator in the closed position, fill the tank with grain.
- 2) With the PTO disengaged, fold the discharge auger to the upright position.
- 3) **IMPORTANT:** After the upper auger is in the upright position, be sure to start the PTO at a SLOW RATE OF SPEED until the lugs on the upper auger engage the drive dog on the bottom auger. Failure to follow this procedure may cause extensive damage to both the drive dog and the drive line.
- 4) Increase the PTO speed and slowly open the inside tank gate until the gate indicator rod located above the upper auger is halfway between the Open and Closed position. When grain begins flowing from the discharge auger, continue to open the gate to obtain the desired unload rate.
- 5) To stop unloading grain, return the inside tank gate to the closed position and allow the material inside the auger to unload. **For complete cleanout, gradually close the inside tank gate.** Once the grain has ceased to flow, disengage the PTO and allow its rotation to come to a complete stop. The upper auger is now ready to be returned to the stow position. **IMPORTANT:** Do Not Pull the grain cart through the field with the unloading auger in the upright position. Failure to return the auger to the lowered stow position may damage the hinge and greatly reduce the life of the auger system.

Lubrication Service Schedule

IMPORTANT: Your grain cart has grease fittings at all critical points. These should be serviced before the grain cart is put into operation.

⚠ WARNING

BE CERTAIN THAT ALL POWER IS SHUT OFF BEFORE SERVICING THE GRAIN CART

PTO & DRIVELINE: The grease fittings on the PTO should be serviced after every 8 hours of use. Service the grease fittings on each of the drive bearings and also the universal joint after every 8 hours of use.

AUGER FOLDING MECHANISM: One grease fitting is located on the pivot pin of the folding auger. This fitting should be serviced after every 8 hours of use. Service the grease fitting on the hanger bushing assembly (top end of the lower auger assembly) after every 8 hours of use or as needed.

SPRING LOADED UPPER AUGER BEARING: Service the grease fitting on the upper auger bearing (located at the top end of the upper auger assembly) after every 8 hours of use. Lubricate the springs and retaining bolts on the bearing before prolonged storage of the grain cart.

GEARBOX: Gearbox lubricant has been added to the gearbox during final assembly. Re-check the lubricant level before initial operation of the grain cart, then periodically according to use. An inspection plug is located in the center of the top of the gearbox mount plate. To check the fluid level, remove the vented inspection plug and drain plug at the bottom of the gearbox. Drain the lubricant. Return the drain plug and refill the gearbox. Use 24 ounces (0,71 liters) for 18" and 20" carts. Use 3 quarts for 22" carts. The gearbox is properly filled when half full of lubricant. **DO NOT OVERFILL.** Use EP 80-90 gearbox lubricant or equivalent.

Roll Tarp U-Joint	Once Annually
Upper Auger Flighting	Every 8hrs of use.
Auger Pivot	Every 8hrs of use.
Driveline	Every 8hrs of use.
Drive Dog	Every 8hrs of use.

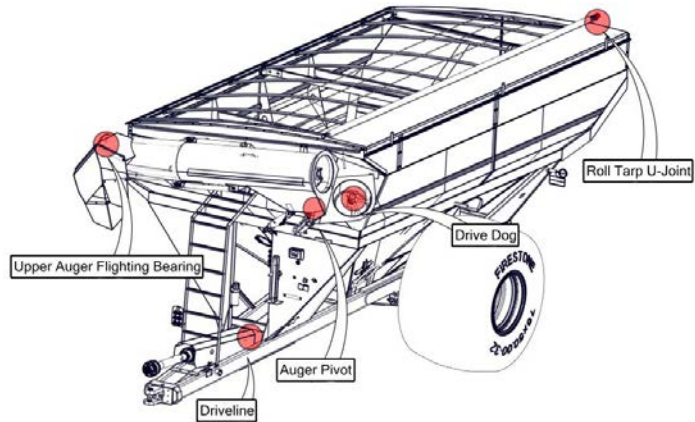

Routine Maintenance

⚠ WARNING

BE CERTAIN ALL POWER IS SHUT OFF WHEN SERVICING THE GRAIN CART

- Re-pack the wheel bearings at least once a year. Use Bearing Gard MK1 or equivalent lubricant. Also check the seal for wear and replace if necessary.
- Check the grain cart periodically for cracks in welds and for other structural damage. Have cracked welds fixed immediately. Failure to do so could result in extensive damage to the grain cart and greatly reduce the life of the cart.
- Lubricate the slides on the clean-out door.
- Check all hydraulic hoses for wear and replace as necessary.
- Make sure all tires are properly inflated. See INITIAL OPERATION AND MAINTENANCE in the Owner's Manual for recommended instructions for tire pressure. It is important that tires are inspected before and after unit is loaded.
- Check PTO for wear of plates in the slip clutch. Replace if needed.
- Make sure that all guards and shields are in place before operating the grain cart.
- Make sure wheel nuts are tight before operating the grain cart. Wheel Nuts should be checked during initial operation of the cart and after every 10 hours of use.
- Make sure set screws are tight in bearings along drive line and in U-joints.

Trouble Shooting

⚠ WARNING

MAKE SURE THAT ALL POWER IS SHUT OFF BEFORE SERVICING THE GRAIN CART. MAINTENANCE AND REPAIR SERVICE WORK TO BE PERFORMED BY QUALIFIED SERVICEMEN ONLY.

Trouble...	Possible Cause...	Possible Remedy...
Auger will not return to down position or move from stow position.	<p>Dirt In Restrictor (see pg. 14)</p> <p>Faulty Check Valve</p> <p>Upper flighting and lower flighting are locked together (see pg. 14)</p>	<p>Remove restrictor fittings from outside hydraulic cylinder and clean out dirt</p> <p>Replace Check Valve</p> <p>Bearing on top of upper auger flighting need adjusting. When the auger is in the engaged position, there must be 1/8" (0,32cm) gap between bottom of top bearing and top of upper tube housing (SEE ADJUSTING THE UPPER AUGER FLIGHTING)</p>
Hanger Bushing Assembly at the top of the lower auger flighting is hot	Top of the hanger bushing assembly is rubbing against the drive dog (See pg.13)	<p>Loosen the two bolts and re-adjust the position of the hanger bushing assembly. Re-tighten bolts.</p> <p>Remove the lower flighting assembly and place a shim between the spline coupler and the gearbox.</p>
Excessive Vibration	<p>Auger flighting or shaft is bent</p> <p>Drive shaft is bent</p>	<p>Straighten or replace auger flighting</p> <p>Replace or straighten drive shaft</p>
Grain flow stoppage	<p>Bolt sheared in drive dog</p> <p>Folding auger before complete stop</p> <p>PTO key sheared</p>	<p>Replace bolt in drive dog. Engage upper and lower flighting at a slow rate of speed. (Drive dogs and lugs are being engaged too fast.)</p> <p>Upper and lower flightings are disengaging before auger comes to a complete stop. Replace bolt in the drive dog. Never engage or disengage the upper and lower flightings until the augers come to a complete stop.</p> <p>Replace key and tighten set screw.</p>
Auger tube is breaking away from the grain cart at the hinge area or the ram in the hydraulic folding cylinder is bent	Upper auger is extended in the upright position while traveling in the field	Repair or replace folding cylinder if necessary. Remember to lower auger to the field position after unloading.

Adjusting the Slip Clutch

- 1) Make sure the tractor is off and the PTO is disengaged.
- 2) Disconnect the driveline from the tractor.
- 3) Locate the (6) bolts (Item 8) on the O.D. of the clutch pack. Loosen the bolts until they rotate freely, finger tighten each bolt, and then tighten each bolt one half turn.
- 4) Attach the implement to the tractor with a hitch pin, and the drive line to the tractor PTO shaft.
- 5) Start the tractor. Engage the PTO and run a few seconds, or until the friction clutch visibly smokes.
- 6) Disengage the tractor PTO and shut the tractor off.
- 7) Disconnect the driveline from the tractor.
- 8) Tighten the (6) bolts (Item 8) on the O.D. of the clutch pack until the compression plate (Item 7) is in contact with the housing (Item 1), then keep tightening each bolt to 30 ft. lbs.
- 9) Locate the (4) bolts (Item 10) that attach the yoke & hub (Item 12) to the clutch pack and check that each bolt is tightened to 30 ft. lbs.

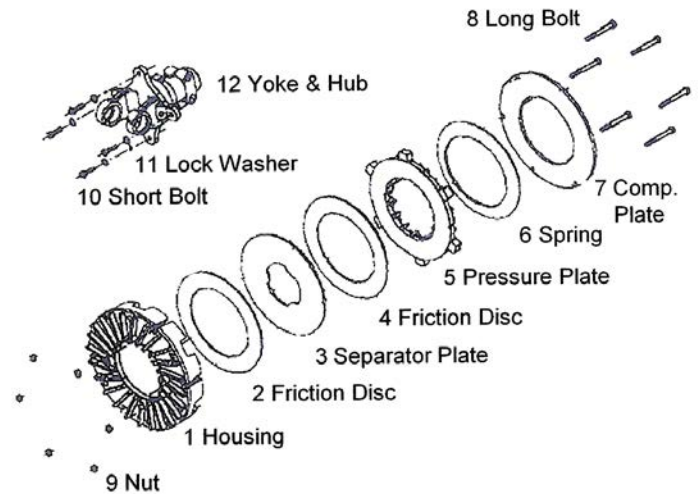

Adjusting the Lower Flighting and Hanger Bushing Assembly

⚠ WARNING

MAKE SURE THAT ALL POWER IS SHUT OFF BEFORE ADJUSTING THE FLIGHTING ASSEMBLY.

If the drive-dog and hanger assembly are becoming excessively hot during unloading, the lower flighting and/or hanger may need adjusting. The hanger bushing assembly has elongated holes where it attaches to the outer tube assembly. Loosen the two 3/8" bolts on the hanger bushing assembly. Adjust the hanger either up or down and vertically center it between the flighting and drive dog. Re-tighten the bolts. Make certain that the flighting center and drive-dogs do not rub the hanger bushing assembly, causing them to become hot.

If the hanger can no longer be adjusted by moving it up or down on the elongated holes, both the hanger bushing assembly and the lower flighting will have to be removed. See instructions on pg. 36 for flighting removal. After removing them from the tube assembly, place a shim [between 1/8" (0,32cm) to 3/16" (0,48cm) thick] where the gearbox and the spline coupler (welded to the lower flighting). Replace the lower flighting and reattach the hanger to the tube assembly. Readjust the hanger assembly. NOTE: The bottom of the lower flighting is not attached to the gearbox with any bolts or set screws but may be 'frozen' fast. Be careful when removing the lower flighting from the gearbox. For easier removal of the lower flighting, keep the gearbox at the bottom intact, remove the 2 3/8" bolts from the hanger bushing assembly and pull the lower flighting off of the gearbox.

After adjusting the lower flighting, move the upper auger to the unload position and check the upper flighting for readjustment.

Adjusting the Upper Flighting

WARNING

MAKE SURE ALL POWER IS SHUT OFF BEFORE ADJUSTING THE FLIGHTING ASSEMBLY

If the upper and lower augers do not properly separate during the unfolding sequence, the upper flighting may need adjusting. Before making adjustment to the upper flighting, check to see if the lugs and drive dogs on the auger assemblies are locking together. If they are not locked together, check to see if dirt is in the restrictor or if a faulty check valve on the hydraulic cylinder used to raise and lower the upper auger assembly may be causing the problem. If dirt is in the restrictor, see "Removing Dirt From Restrictors On Hydraulic Cylinders" below.

Fold the upper tube assembly into the upright position. Position the upper flighting in the engaged position with the lower flighting. Locate the four-hole flange bearing on the top of the upper auger tube housing. With the upper flighting in the engaged position, check the spacing between the upper bearing and the upper tube housing. There must be an 1/8" (0,32cm) space between the base of the four-hole flange bearing and the upper tube housing. If there is NOT a space between the bearing and the upper tube housing, or if there is more than 1/8" (0,32cm) space, the upper flighting will need to be adjusted. To adjust the upper flighting, loosen the 1 1/4" hex nuts both above and below the four-hole flange bearing. Move the 1 1/4" hex nuts up or down the threaded shaft on the top of the auger flighting shaft until the bearing moves to approximately 1/8" (0,32cm) above the base of the upper tube housing. When the four-hole flange bearing is properly located, tighten both 1 1/4" hex nuts together to secure the bearing position.

If the upper and lower flighting still does not separate properly during the folding sequence, a small bevel may need to be removed from the inside of the lugs where they engage the drive dogs on the auger assemblies. Grind approximately 1/8" (0,32cm) from the corner of the lugs where they touch against the drive dogs.

Removing Dirt From The Restrictors On The Hydraulic Cylinder

WARNING

MAKE SURE THAT ALL POWER IS SHUT OFF AND THE UPPER AUGER TUBE IS IN THE DOWN POSITION BEFORE REMOVING THE RESTRICTORS

Remove restrictors from the 90 degree street elbow on the hydraulic cylinder. Remove dirt from the fitting to allow hydraulic oil to flow through the restrictor. Reattach the restrictor to the street elbow. Use teflon sealant tape or equivalent on the threads of the restrictor before reattaching.

If the restrictor continues to plug with dirt, replace the restrictor or filter the hydraulic oil in your system.

Storage Preparation

IMPORTANT: When the grain cart is not going to be used for a period of time, store the cart in a dry, protected place. Leaving your grain cart outside, open to the weather will shorten its life.

Follow the procedure below when your grain cart is placed in storage for periods up to six months.

1. Cover electronic monitor (if equipped) with plastic before washing the grain cart. Wash or clean and completely lubricate the grain cart. See the lubrication service section in this manual.
2. Remove all grain from inside the grain tank, auger tube assemblies, and at the clean-out door.
3. Check the gearbox oil and replace with new EP 80-90 gearbox lubricant or equivalent if necessary.
4. Touch up areas where paint may have worn away. Use a good quality primer paint, especially before re-applying graphite paint to the interior slopes of the grain tank.
5. Retract all hydraulic cylinders to prevent the piston rods from rusting.
6. If the grain cart is equipped with an electronic weigh system, fully charge the battery to prevent freezing. Disconnect the negative (-) ground cable at the battery to prevent possible discharge.
7. Clean the tires before storage. Inflate the tires at regular intervals.
8. Open the clean-out door at the base of the grain tank.

Removing From Storage

- Check the gearbox to make sure it has the appropriate amount of oil.
- If equipped with an electronic scale system, check the battery and make sure that it is fully charged. Reconnect the negative (-) cable.
- Inflate the tires to the correct operating pressure.
- Close the clean out door at the base of the grain tank.
- Make sure all safety shields are in the proper position.

Repair Parts List and Diagrams

When performing maintenance work, wear sturdy, rough-soled work shoes and protective equipment for eyes, hair, hands, hearing and head. Follow the Operator's Manual instructions to ensure safe and proper maintenance and repair.

Your local, authorized dealer can supply genuine replacement parts. Substitute parts may not meet original equipment specifications and may be dangerous.

⚠ WARNING

MAKE SURE ALL POWER IS SHUT OFF BEFORE PERFORMING ANY MAINTENANCE OR REPAIR WORK.

Hub & Spindle Assembly W-881

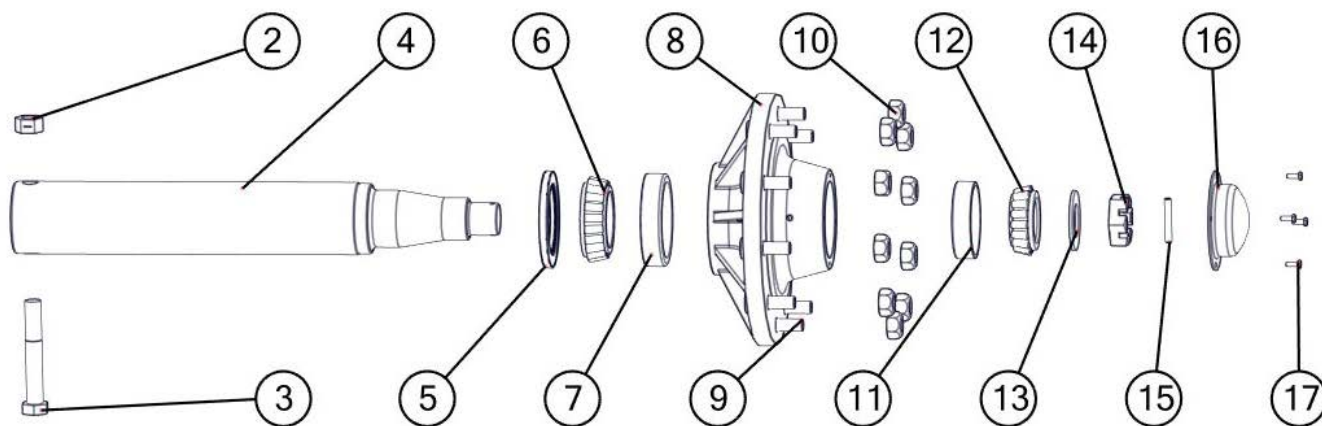

#	Description	Part. No.
1	Hub and Spindle Assembly Complete (HAS-650D)	JM0019940
1	Hub and Spindle Assembly Complete (HAS-650)	JM0022057
2	1\"-8 Gr5 Z Centerlock Hex Nut	JM0002149
3	1\" x 7\" Gr5 Z Hex Bolt (165400)	JM0016689
4	4-1/2\" Spindle x 30-1/2\" (281900)	JM0018794
4	4-1/2\" x 20-1/4\" Spindle (1144 Stress-Proof)	JM0019937
5	Seal (6\" OD - 3-3/4\" ID) for hub w/ scales (since March 2000)(750-35)	JM0021456
5	Seal (6\" OD) 1-906979 (CR-43771)	JM0018955
6	Large Bearing (910346)	JM0018849
7	Large Race (HM212049)	JM0018848
8	Hub with large bearing and small races, 3/4\" studs & nuts (13.19 bolt circle) (11.13 pilot)(W-881)	JM0020510
9	3/4\"-16 Wheel Stud (913564)	JM0018957
10	3/4\"-16 Wheel Nut (913571)	JM0018958
11	Small Race (HM212011)	JM0018854
12	Small Bearing (910347)	JM0018852
13	Spindle Washer (913635)	JM0015900
14	Large Castle Nut (912973)	JM0015899
15	Cotter Pin (905945)	JM0018956
16	Dust Cap (909921)	JM0018954
17	1/4\"-20 x 1\" Gr5 Z Hex Bolt (141G5B)	JM0002095

HUB & SPINDLE ASSEMBLY 250-10
Grain Carts with 6" Diameter Spindles

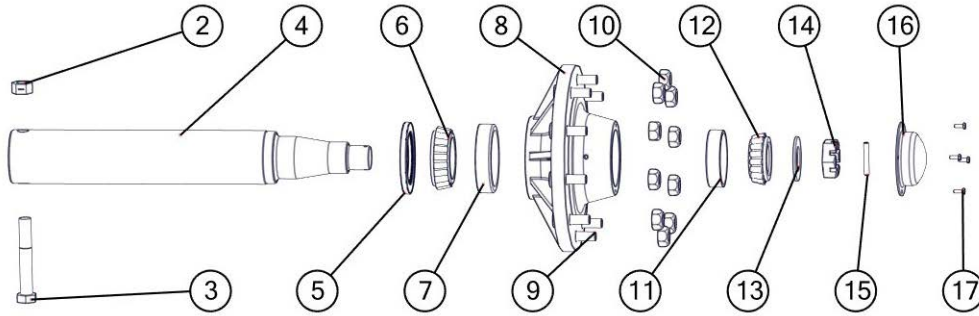

#	Description	Part. No.
1	Hub and Spindle Assembly Complete with 3/4" -16 Studs and Nuts (HSA-1075-34)	JM0025709
1	Hub and Spindle Assembly Complete with 22MM Studs and Nuts (HSA-1075-22)	JM0019927
2	1"-8 Gr5 Z Centerlock Hex Nut	JM0002149
3	1"-8 X 8" Gr5 Z Hex Bolt (165450)	JM0001487
4	6" Spindle - 29-3/4" Long (628)	JM0019102
5	Seal 55179 (Type C) for G250-10,G300-10B, Spring-assisted (CR55179)	JM0019179
6	Large Bearing (71455)	JM0019112
7	Large Race (71750)	JM0019198
8	Hub with studs & nuts (13.19 bolt circle) (11.13 pilot)	JM0019300
8	Hub with large and small races 3/4" -16 Studs & Nuts (1050 & 1075 Carts prior to 2006) (H25000-34)	JM0019927
9	Stud 22MM 1.5 x 9MM 3.55L 1.005 Knurl (22-MMS)	JM0019178
9	3/4"-16 Wheel Stud (for 1050 and 1075 carts prior to 2006)(750-35)	JM0025710
10	22 MM Lug Nut (22-MMNW)	JM0019192
10	3/4"-16 Wheel Nut (for 1050 and 1075 carts prior to 2006)(913571)	JM0018958
11	Small Race (653)	JM0019195
12	Small Bearing (663)	JM0019177
13	Large Spindle Washer (913632)	JM0019106
14	Large Castle Nut (SF-2512)	JM0019108
15	3/8" X 3-1/2" Z Roll Pin (3754)	JM0020001
16	6" Diameter Spindle Dust Cap (D-25000)	JM0019109
17	1/4"-20 X 1" Gr5 Z Hex Bolt (141G5B)	JM0002095

Power Take-Off (PTO) Shaft Assembly
1-3/4" & 1-3/8" Weasler Automatic Clutch - Black in Color

#	Description	Part. No.
1	Back Half PTO	JM0018513
1	Back Half PTO (XL)	JM0030331
2	1-3/4" Front Half PTO	JM0018514
2	1-3/4" Front Half PTO (XL)	JM0030330
2	1-3/8" Front Half PTO	JM0024367
2	1-3/8" Front Half PTO (XL)	JM0030640
3	55ECross Kit	JM0018449
4	Auto Clutch	JM0018500
5	Yoke, Tube & Sleeve	JM0018519
5	Yoke, Tube & Sleeve (XL)	JM0031647
6	Yoke & Shaft Assembly	JM0018520
6	Yoke & Shaft Assembly (XL)	JM0031648
7	1-3/4" Spring Lock Yoke	JM0018506
7	1-3/8" Spring Lock Yoke	JM0024353

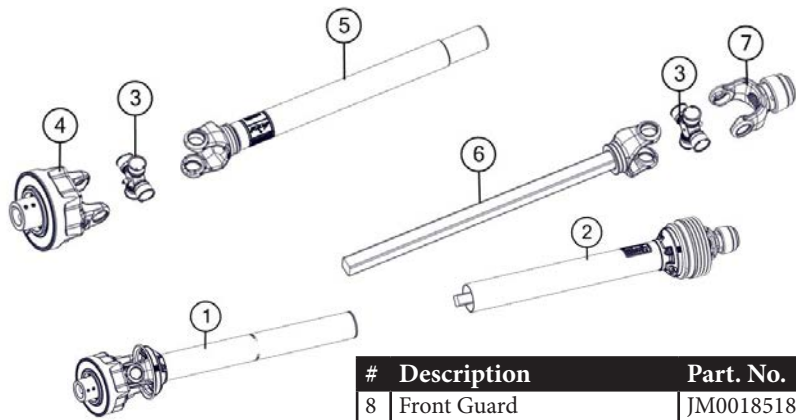

#	Description	Part. No.
8	Front Guard	JM0018518
8	Front Guard (XL)	JM0030642
8	Back Guard	JM0018517
8	Back Guard (XL)	JM0030645
9	1-3/4" PTO Complete	JM0018443
9	1-3/4" PTO Complete (XL)	JM0030332
9	1-3/8" PTO Complete	JM0024333
9	1-3/8" PTO Complete (XL)	JM0030641

Power Take-Off (PTO) Shaft Assembly
80-Series Comer Manufactured PTO - Yellow in Color
Standard 18", 20", and 22" Diameter Augers

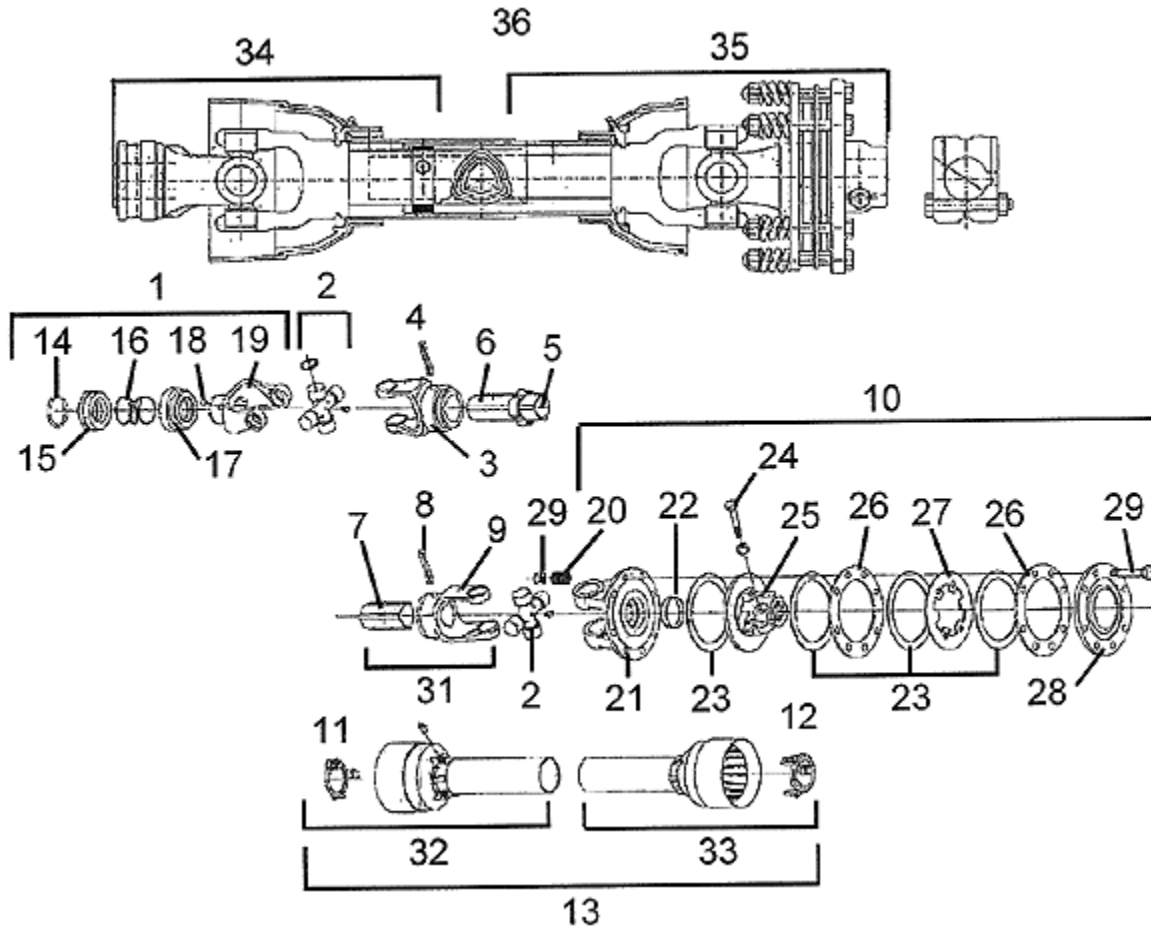

#	Description	Part. No.
1	Complete Collar Yoke, 1-3/4" (28428)	JM0025180
1	Complete Collar Yoke, 1-3/8" (28426)	JM0025181
2	Cross Journal Set (18130)	JM0025144
3	Outer Yoke (18133)	JM0025145
4	Roll Pin for Outer Tube (00243)	JM0025146
5	Bushing with Grease Nipple (18210)	JM0025147
6	Complete Outer Tube (30710)	JM0025148
7	Inner Tube (90010)	JM0025149
8	Roll Pin for Inner Tube (00271)	JM0025150
9	Inner Yoke (18134)	JM0025151
10	Complete Slip Clutch (84033)	JM0025152
11	Retain Collar for Outer Tube (19121)	JM0025153
12	Retain Collar for Inner Tube (19122)	JM0025154
13	Complete Guard (27820)	JM0025155
14	Outer Circlip (00452)	JM0025156
15	Sliding Sleeve Collar (16490)	JM0025157
16	Spring (15107)	JM0025158
17	Fixed Sleeve (16489)	JM0025159
18	Ball 5/8" (00085)	JM0025160
19	Yoke C15 (18428)	JM0025161

#	Description	Part. No.
20	Spring (14022)	JM0025162
21	Flanged Yoke (18016)	JM0025163
22	Bushing (19019)	JM0025164
23	Lining Ring (6" OD x 3-1/2" ID)	JM0025165
24	Bolt M12 x 1.25 x 65 with Nut (00502)	JM0025166
25	Clutch Support F40 (18453)	JM0025167
26	Inner Plate (19014)	JM0025168
27	Intermediate Plate (19115)	JM0025169
28	Pressure Plate (19916)	JM0025170
29	Bolt & Nut M10 x 100 (00548)	JM0025171
30	Female Tube and Yoke (80039)	JM0025172
31	Male Tube and Yoke w/Roll Pin (80529)	JM0025173
32	Half Female Guarding (67820)	JM0025174
33	Half Male Guarding (37820)	JM0025175
34	Front Half PTO, 1-3/4" (21110)	JM0025176
34	Front Half PTO, 1-3/8" (21110-138)	JM0025177
35	Back Half of PTO with Clutch (36510)	JM0025178
36	PTO Complete, 1-3/4" (CPTO-134)	JM0020024
36	PTO Complete, 1-3/8" (CPTO-138)	JM0020021
37	Tee Key for Plastic Retain Collar (PTK-2)	JM0025179

**130 Degree Gearbox Assembly for 22" Diameter Augers (Comer)
For Models 1051-22 & 1151-22 Grain Carts**

#	Description	Part. No.
1	Gearbox Complete (T-325)	JM0025120
2	2" Output Shaft with 30 Tooth Gear (M56)	JM0025121
3	Double Lip Seal (55X100)	JM0039281
4	Shim (997)	JM0025123
5	Bolt (M10X25)	JM0025124
6	Casing (T325C)	JM0025125
7	Bearing With Race (31307)	JM0025126
8	Shim (677)	JM0025127
9	Oil Fill Plug . Breather (386AS)	JM0025128
10	90 Degree Elbow (90EL)	JM0025129
11	Bearing With Race (30209)	JM0025130
12	Snap Ring (85UNI)	JM0025131
13	End Cap (T-325EC)	JM0025132
14	1-3/4" Input Shaft with 15 Tooth Gear (Z15M56)	JM0025133
15	Shim (847)	JM0025134
16	Plug (38PL)	JM0025135
17	Shim (897)	JM0025136
18	Snap Ring (90UNI)	JM0025137
19	Double Lip Seal (50X100)	JM0025138
20	Bearing with Race (30210)	JM0025139
21	Cover (T-325CO)	JM0025140
22	Bearing with Race (30211)	JM0025141
23	Snap Ring (100UNI)	JM0025142
24	Seal Guard with 8MM Bolts (SG-8MM)	JM0025143

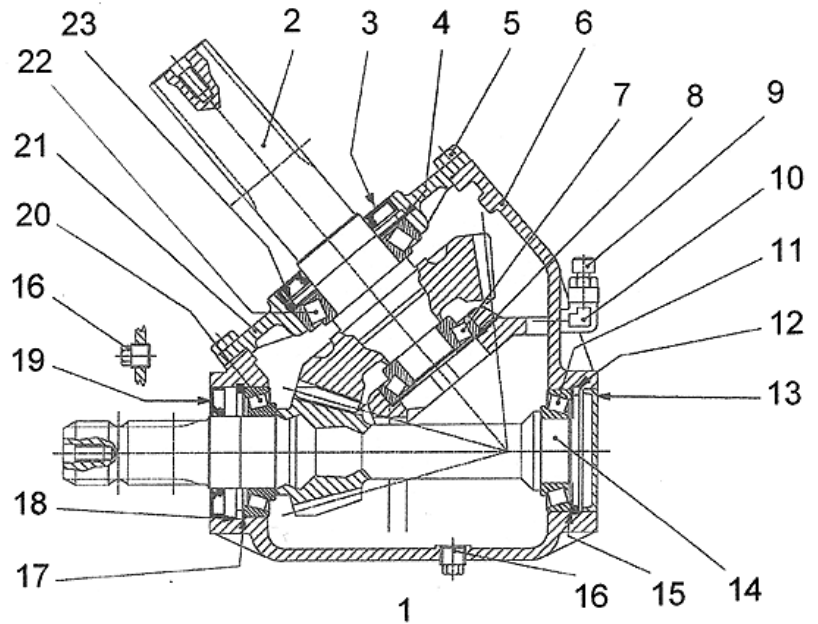

**130 Degree Gearbox Assembly for 22" Diameter Augers (since 2009) (WEASLER)
For Models 1051-22 & 1151-22 Grain Carts**

#	Description	Part. No.
1	Housing Set (70-001114)	JM0025053
2	Bearing, 32210 (71-20017)	JM0025054
3	Bearing Cone, 3780 (71-20044)	JM0025055
4	Bearing Cup, 3720 (71-20033)	JM0025056
5	1-3/4" Input Shaft & Gear Assembly (74-60123)	JM0025057
6	2" Output Shaft & Gear Assembly (74-60125)	JM0025058
7	End Cap Seal, 2" x .276" (71-40016)	JM0025060
8	Seal, 1.75" x 2.717 x .513 (71-40052)	JM0025061
9	Seal, 2 x 3.196 x .433 (71-40080)	JM0025062
10	End Cap Seal, 3.19 x .315 (71-40079)	JM0025063
11	Spacer (71-50160)	JM0025064
12	Spacer (71-50161)	JM0025065
13	Spacer (71-50172)	JM0025066
14	1/2" Bushing 1/8" Relief Plug (72-20011)	JM0025067
15	1/2" Pipe Plug (72-20007)	JM0025068
16	Cap Screw 3/8"-16 UNC x 2.52" (72-0002)	JM0025069
17	130 Degree Gearbox Complete (130-22W)	JM0018677

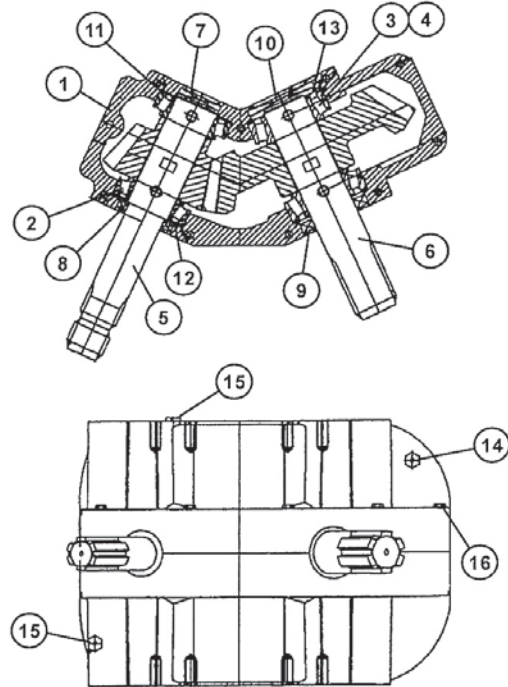

130 Degree Gearbox Assembly For 20" Diameter Augers (SUPERIOR)

#	Description	Part. No.
1	Casting, Upper Half (A0150)	JM0025088
2	Casting, Lower Half (AO149)	JM0025089
3	1-3/4" Input Shaft (A0142)	JM0025090
4	1-3/4" Output Shaft (A0143)	JM0025091
5	18 Tooth Gear (H61S18)	JM0025092
6	29 Tooth Gear (H61S29)	JM0025093
7	Shim, Arbor (H00101-01)	JM0025094
8	Bearing, Cup (414276)	JM0025077
9	Bearing, Cone (514137)	JM0025078
10	Bearing, Cup (413620)	JM0025095
11	Bearing, Cone (413687)	JM0025096
12	Seal (617285)	JM0025097
13	End Cap (400301)	JM0025076
14	Bolt (438225)	JM0025085
15	Plug (400300)	JM0025080
16	Bushing (4003VB)	JM0025073
17	Plug, Vent (2003PR)	JM0025081
18	Plug (200300)	JM0025075
19	130 Degree Gearbox Complete (H130-9)	JM0017840

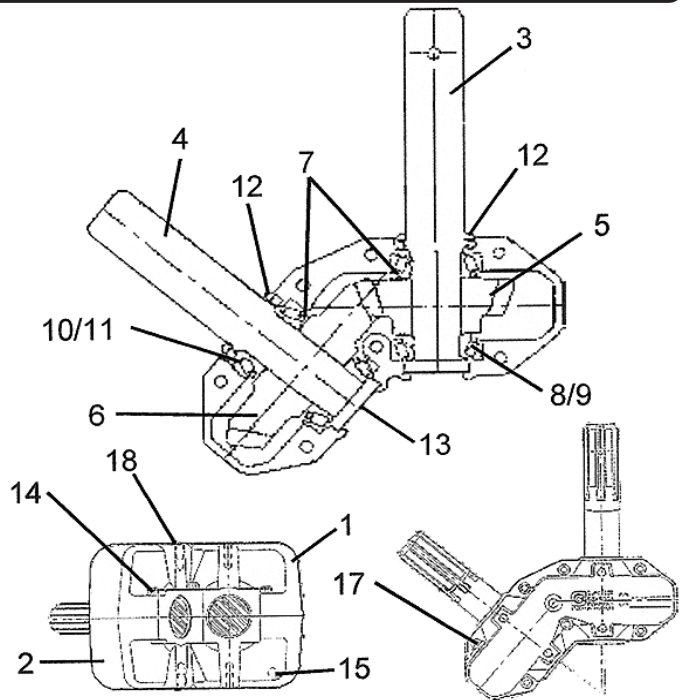

Drive Line Assembly

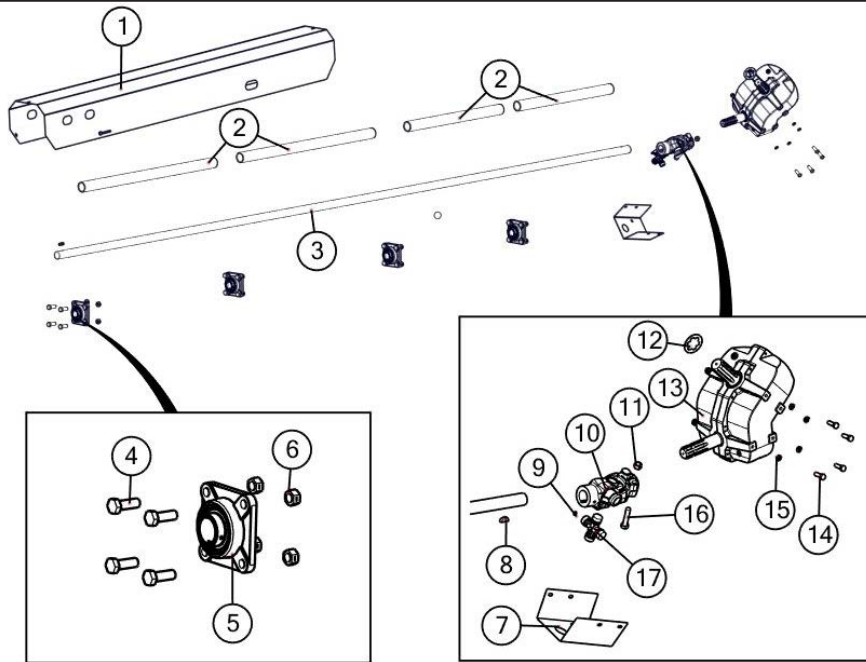

#	Description	Part. No.
1	Driveline Shield, 1050, 1051, 1130, 1131, 1150, 1151, 1250, 1251	JM0012517
2	40" Driveline Cover PVC	JM0027151
3	150" Driveline, 1050, 1051, 1130, 1131, 1150, 1151, 1250, 1251, March 2006 & later, Serial # 2200 and higher	JM0021345
3	156" Driveline, 1050, 1051, 1150, 1151, Prior to March 2006	JM0026233
4	5/8"-11 x 1-3/4" Gr5 Z Hex Bolt	JM0016681
5	1-3/4" Flange Bearing 4 Hole, 750-18, 875-18	JM0018774
6	5/8"-11 Gr5 Z Centerlock Hex Nut	JM0002146
7	Knuckle Guard	JM0012698

#	Description	Part. No.
8	Driveline Key 3/8" x 1-1/2"	JM0018772
9	3/8"-16 x 1/2" Set Screw (SS-3812)	JM0019044
10	U-Joint Assembly, 44 Series	JM0017957
11	5/8"-11 Gr5 Z Centerlock Hex Nut	JM0002146
12	Gearbox Washer	JM0000083
13	Gearbox Assembly (See Pages 24 through 26)	-----
14	1/2"-13 x 1-1/2" Gr5 Z Hex Bolt	JM0002100
15	1/2" Zinc Finish Lock Washer	JM0019021
16	5/8"-11 x 3" Gr5 Z Hex Bolt	JM0002105
17	Cross Kit 44R, CK-44R	JM0017958

Hitch Assembly

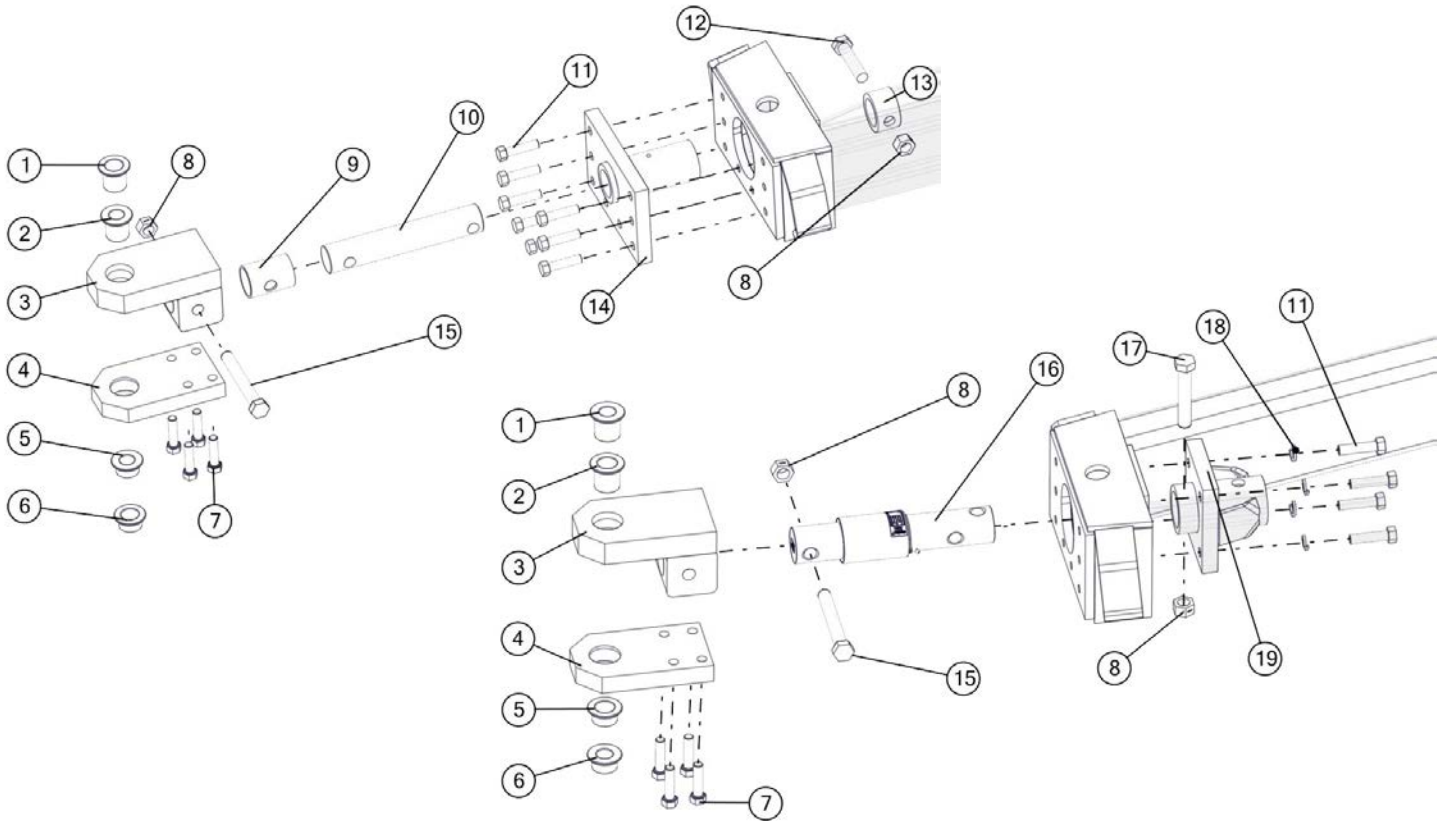

#	Description	Part. No.
1	1-1/2" Pin adapter for Grain Cart Clevis Hitch Tang	JM0014203
2	1-1/4" Pin adapter for Grain Cart Spade Hitch	JM0019032
3	Hitch Weldment	JM0017978
4	Clevis Hitch Tang	JM0017976
5	1-1/4" Pin adapter for Grain Cart Clevis Hitch Tang	JM0019031
6	1-1/2" Pin adapter for Grain Cart Clevis Hitch Tang	JM0014206
7	3/4"-16 x 3" Fine Thread Hex Bolt	JM0002107
8	1"-8 Gr5 Z Centerlock Hex Nut	JM0002149
9	2-1/2" Hitch Spindle Sleeve	JM0018258
10	2-7/8" Hitch Spindle, 1000-20 through 1501-22, Non-Scale	JM0025787
11	3/4"-16 x 3" Gr8 YZ Hex Bolt (343HB)	JM0018542
12	1"-8 x 4-1/2" Gr5 Z Hex Bolt (1412G5B)	JM0016687
13	2-7/8" Hitch Spindle Collar	JM0025785
14	Hitch Spool Plate 2-7/8" (HSPS-2)	JM0025783
15	1"-8 x 7-1/2" Gr8 YZ Hex Bolt (165410)	JM0017944
16	Weigh-Tronix - 2-7/8" Weigh Bar, 1050 through 1151, All Duals, 3 Point Scale System (278WB)	JM0019969
16	Digi-Star - 2-7/8" Weigh Bar, 1050 through 1151, 5 Point Scale System (278WB-T)	JM0000355
17	1"-8 x 5-1/2" Gr5 Z Hex Bolt (1512G5B)	JM0002110
18	3/4" Zinc Finish Lock Washer	JM0018544
19	Weigh Bar Receiver Weldment Scales 2-7/8" (WBW-278)	JM0000019

22" Upper & Lower Auger Assembly

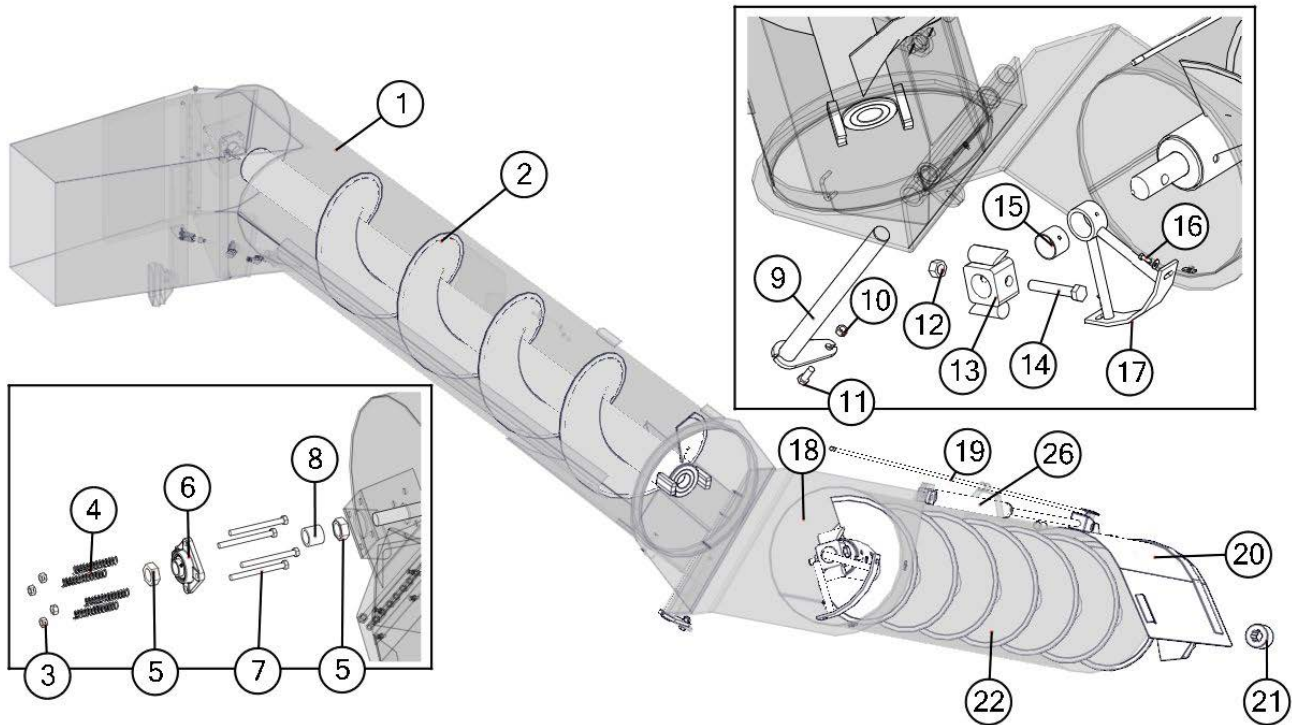

#	Description	Part. No.
1	22" Upper Auger Tube Assembly 130", 1050-22, 1051-22, 1150-22, 1151-22, 1325-22, 1326-22	JM0018304*
2	22" Upper Flighting (leaned) welded to 6" x 121" pipe with 9" shaft (UF-22GS)	JM0019702
3	1/2"-13 Gr5 Z Centerlock Hex Nut	JM0001511
4	Compression Spring (CMSUAA-4)	JM0018559
5	1-1/4"-12 PN Gr5 Hex Jam Nut	JM0001606
6	1-1/4" Flange Bearing, 4 hole (GRAF-206)	JM0018560
7	1/2"-13 x 5-1/2" Gr5 Z Hex Bolt	JM0001498
8	1-1/2" Spacer	JM0016792
9	22" Hinge Pin Weldment	JM0025101
10	5/8"-11 Gr5 Z Centerlock Hex Nut	JM0002146
11	5/8"-11 x 1-3/4" Gr5 Z Hex Bolt	JM0016681
12	1"-8 Gr5 Z Centerlock Hex Nut	JM0002149
13	22" Drive Dog Weldment 1050-22, 1051-22, 1150-22, 1151-22, 1325-22, 1326-22 (DDW-21222)	JM0002919
14	1"-8 x 6" Gr5 Z Hex Bolt	JM0002111
15	2-1/2" ID Bronze Bushing (BB-212)	JM0016841
16	3/8"-16 x 1" Gr8 Z Hex Bolt	JM0001485
17	22" Hanger Bushing Assembly (HBA-22)	JM0019656
18	Lower Auger Liner 115" with 22" Diameter Auger (LAL-22-2)	JM0034028
19	Indicator Rod 22"	JM0019396
20	Auger Gate Cover (See Grain Cart Assembly)	JM0017850
21	3-3/4" OD x 3" Spline Coupler (SC-334X3)	JM0009701
22	22" Lower Flighting (leaned) welded to 6" x 146 1/4" pipe with Flush-Mount Coupler (on Models 1050-22, 1051-22, 1150-22, 1151-22 since March 2006; Model 1050-22S Serial # 2200 to 2999 and 3060 and higher and Model 1050-22D Serial # 2200 and higher)	JM0021424
22	22" Lower Flighting (leaned) welded to 6" x 148 1/4" pipe with Extended Coupler (Model 1050-22S serial # 3005 to 3059 and Model 1050-22D serial # 1005 to 2199)	JM0026577
22	22" Lower Flighting (leaned) welded to 6" x 142 1/4" pipe with Extended Coupler (Model 1050-22S serial # 3000 to 3004 and Model 1050-22D serial # 1000 to 1003) (6 degree)	JM0026578
26	2" x 36" Hydraulic Cylinder (JD236)	JM0018523
26	Seal Kit for 2" x 36" Hydraulic Cylinder (JD472)	JM0026544

20" Upper & Lower Auger Assembly

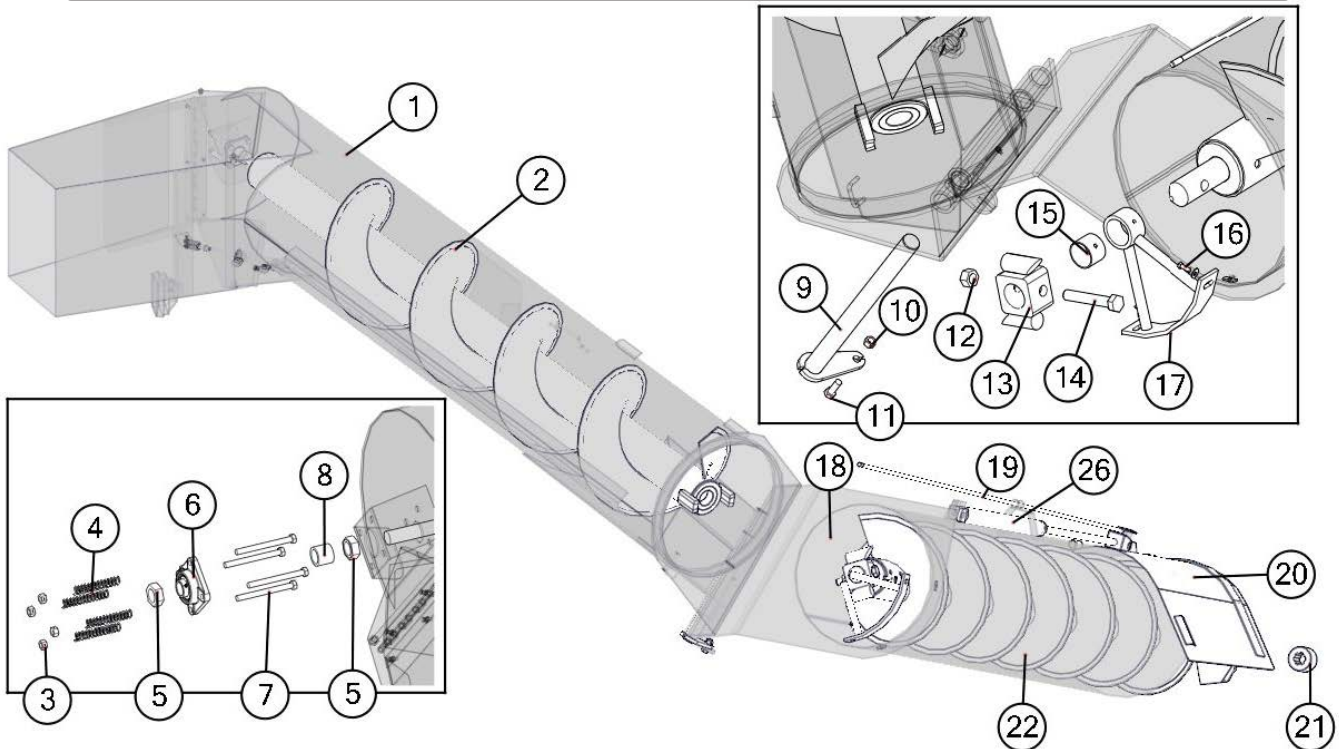

#	Description	Part. No.
1	20" Upper Auger Tube Assembly	JM0018369*
2	20" Upper Flighting welded to 4-1/2" x 120" pipe with 9" shaft (UF-20)	JM0021323
3	1/2"-13 Gr5 Z Centerlock Hex Nut	JM0001511
4	Compression Spring (CMSUAA-4)	JM0018559
5	1-1/4"-12 PN Gr5 Hex Jam Nut	JM0001606
6	1-1/4" Flange Bearing, 4 hole (GRAF-206)	JM0018560
7	1/2"-13 x 5-1/2" Gr5 Z Hex Bolt	JM0001498
8	1-1/2" Spacer	JM0016792
9	Pin Weldment 20"	JM0021236
10	5/8"-11 Gr5 Z Centerlock Hex Nut	JM0002146
11	5/8"-11 x 1.75 Gr5 Z Hex Bolt	JM0016681
12	1"-8 Gr5 Z Centerlock Hex Nut	JM0002149
13	Drive Dog Weldment, 1000-20, 1050-20, 1150-20, 1325-20 (DDW21220)	JM0000093
14	1"-8 X 6" Gr5 Z Hex Bolt	JM0002111
15	2-1/2" ID Bronze Bushing (BB-212)	JM0016841
16	3/8"-16 x 1" Gr8 Z Hex Bolt	JM0001485
17	Hanger Bushing Assembly 20" (HBA-20)	JM0019655
18	Lower Auger Liner 20" (LAL-20)	JM0026559
19	Indicator Rod, 1000-20, 1050-18, 1050-20, 1075-18R, 1150-20, 1325-20 (GI-12-6B)	JM0021282
20	Auger Gate Cover (See Grain Cart Assembly)	JM0021210
21	2-1/2" OD x 3" Spline Coupler (SC-25X3)	JM0016883
22	20" Lower Flighting welded to 4-1/2" x 147-1/2" pipe, 1000-20, 1050-20, 1150-20 (LF-20)	JM0021325
26	2" x 36" Hydraulic Cylinder (JD236)	JM0018523
26	Seal Kit for 2" x 36" Hydraulic Cylinder (JD472)	JM0026544

22" Upper Extended Auger Side Shooter Assembly 16" XL

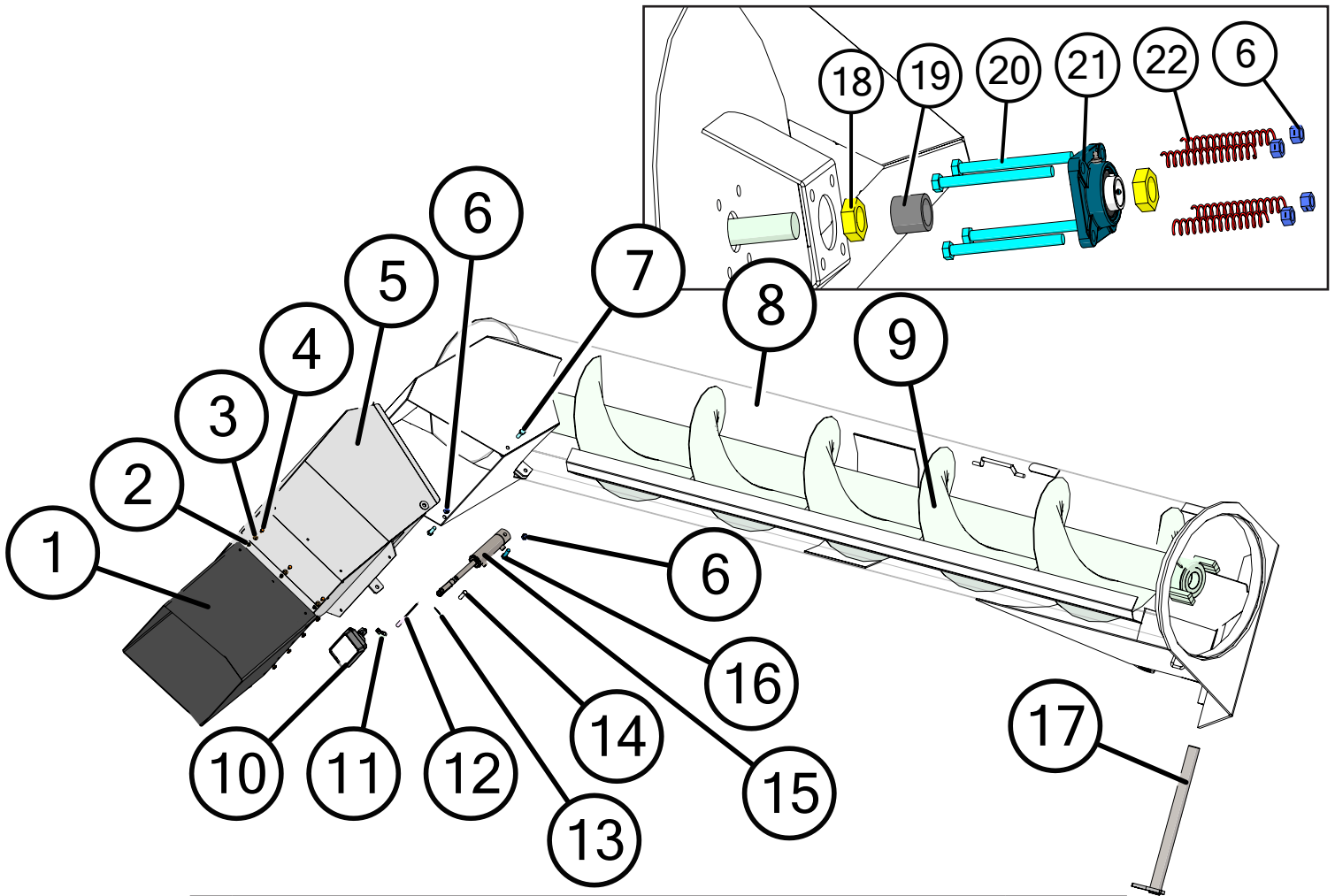

Description	Part No.
1 22" Rubber Tip Spout Addition	JM0014129
2 1/4"-20 Gr2 Z Centerlock Hex Nut	JM0001505
3 1/4" USS Flat Washer	JM0003090
4 1/4"-20 x 1/2" Gr5 Z Hex Bolt	JM0001481
5 22" Side Shooter Tip Spout	JM0017838
6 1/2"-13 Gr5 Z Centerlock Hex Nut	JM0001511
7 1/2"-13 x 1-1/2" Gr5 Z Hex Bolt	JM0002100
8 22" Side Shooter Upper Auger XL 16 inch Weldment	JM0018404
9 22" Longer Upper Flighting (leaned) welded to 6" x 121" pipe with 21" shaft (LUA-22-F)	JM0019696
10 LED Field Light with Bullet Connector	JM0050949
11 3/8" Wire Loom	JM0020450
12 Mercury Switch	JM0017896
13 1/2" x 1-1/2" Cotter Pin	JM0016381
14 1/2" x 1-3/4" Pin	JM0018264
15 1-3/4" x 4" Hydraulic Cylinder	JM0018564
16 1/2"-13 x 2-1/4" Gr5 Z Hex Bolt	JM0016677
17 22" Hinge Pin Weldment	JM0025101
18 1-1/4"-12 PN Gr5 Hex Jam Nut	JM0001606
19 Top Auger Collar 1-1/2" Long (1-3/4" OD)	JM0016920
20 1/2"-13 x 5-1/2" Gr5 Z Hex Bolt	JM0001498
21 1-1/4" Flange Bearing, 4 hole (GRAF-206)	JM0018560
22 Compression Spring (CMSUAA-4)	JM0018559

20" Upper Extended Auger Side Shooter Assembly 16" XL

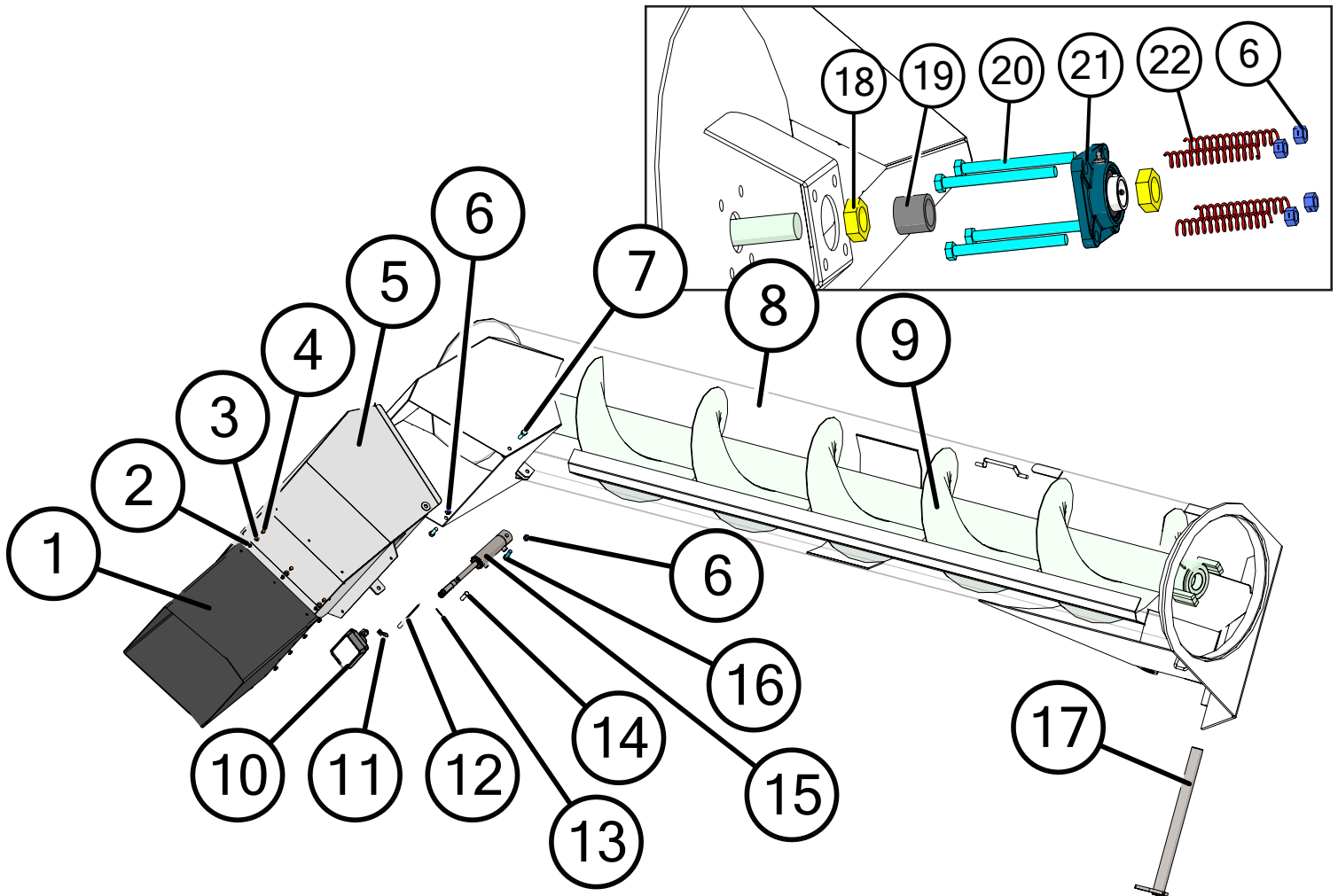

	Description	Part No.
1	20" Rubber Tip Spout Addition	JM0014420
2	1/4"-20 Gr2 Z Centerlock Hex Nut	JM0001505
3	1/4" USS Flat Washer	JM0003090
4	1/4"-20 x 1/2" Gr5 Z Hex Bolt	JM0001481
5	20" Side Shooter Tip Spout	JM0000781
6	1/2"-13 Gr5 Z Centerlock Hex Nut	JM0001511
7	1/2"-13 x 1-1/2" Gr5 Z Hex Bolt	JM0002100
8	20" Side Shooter Upper Auger XL 16 inch Tube Weldment	JM0001332
9	20" Longer Upper Flighting welded to 4-1/2" x 120" pipe with 21" shaft (LUA-20-F)	JM0021321
10	LED Field Light with Bullet Connector	JM0050949
11	3/8" Wire Loom	JM0020450
12	Mercury Switch	JM0017896
13	1/2" x 1-1/2" Cotter Pin	JM0016381
14	1/2" x 1-3/4" Pin	JM0018264
15	1-3/4" x 4" Hydraulic Cylinder	JM0018564
16	1/2"-13 x 2-1/4" Gr5 Z Hex Bolt	JM0016677
17	Pin Weldment 20"	JM0021236
18	1-1/4"-12 PN Gr5 Hex Jam Nut	JM0001606
19	Top Auger Collar 1-1/2" Long (1-3/4" OD)	JM0016920
20	1/2"-13 x 5-1/2" Gr5 Z Hex Bolt	JM0001498
21	1-1/4" Flange Bearing, 4 hole (GRAF-206)	JM0018560
22	Compression Spring (CMSUAA-4)	JM0018559

20" & 22" Slider Auger Assembly

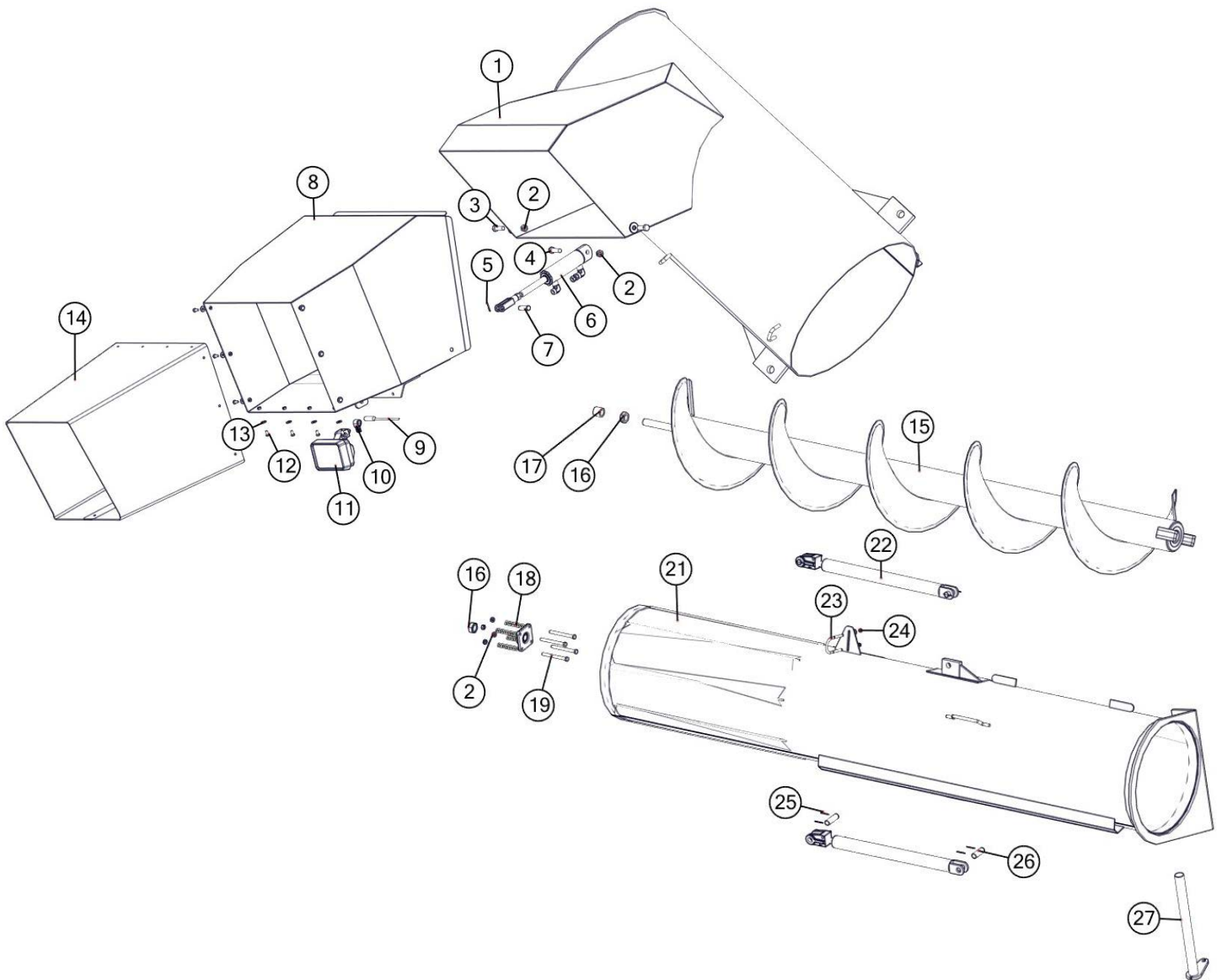

#	Description	Part. No.
1	20" Side Shooter Slider Weldment	JM0000785
1	22" Side Shooter Slider Weldment	JM0017839
2	1/2"-13 Gr5 Z Centerlock Hex Nut	JM0001511
3	1/2"-13 x 1-1/2" Gr5 Z Hex Bolt	JM0002100
4	1/2"-13 x 2-1/4" Gr5 Z Hex Bolt	JM0016677
5	1/2" x 1-1/2" Cotter Pin	JM0016381
6	1-3/4" x 4" Hydraulic Cylinder	JM0018564
7	1/2" x 1-3/4" Pin	JM0018264
8	20" Side Shooter Tip Spout	JM0000781
8	22" Side Shooter Tip Spout	JM0017838
9	Mercury Switch	JM0017896
10	3/8" Wire Loom	JM0020450
11	Field Light	JM0001881
12	1/4"-20 x 1/2" Gr5 Z Hex Bolt	JM0001481
13	1/4" USS Flat Washer	JM0003090
14	20" Rubber Tip Spout Addition	JM0014420
14	22" Rubber Tip Spout Addition	JM0014129

#	Description	Part. No.
15	20" Slider Upper Auger Flighting	JM0021319
15	22" Slider Upper Auger Flighting	JM0019700
16	1-1/4"-12 PN Gr5 Hex Jam Nut	JM0001606
17	Bearing Spacer	JM0016792
18	Top Bearing Springs	JM0018559
19	1/2"-13 x 5-1/2" Gr5 Z Hex Bolt	JM0001498
20	1-1/4" Bearing	JM0018560
21	20" Slider Top Tube Weldment	JM0018300*
21	22" Slider Top Tube Weldment	JM0018374*
22	Slider Cylinder	JM0018210
23	3/8" Round U-Bolt	JM0018627
24	3/8"-16 Gr5 Z Centerlock Hex Nut	JM0001512
25	1" x 3" Cotter Pin	JM0003064
26	1" x 3" Clevis Pin	JM0003065
27	20" Auger Hinge Pin Weldment	JM0021236
27	22" Auger Hinge Pin Weldment	JM0025493

Hydraulic Flow Control Spout For Sliders

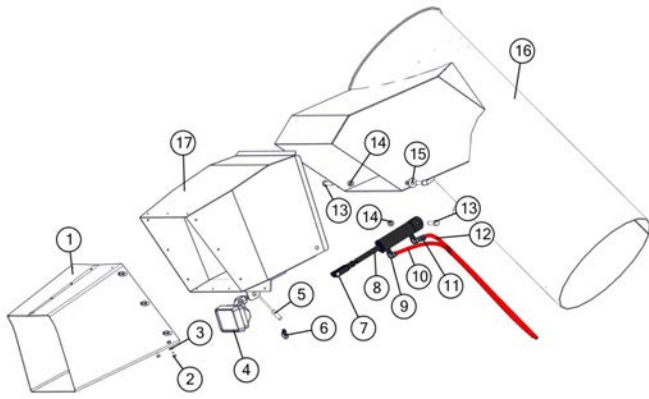

Side Shooter Slider Flow Control Spout

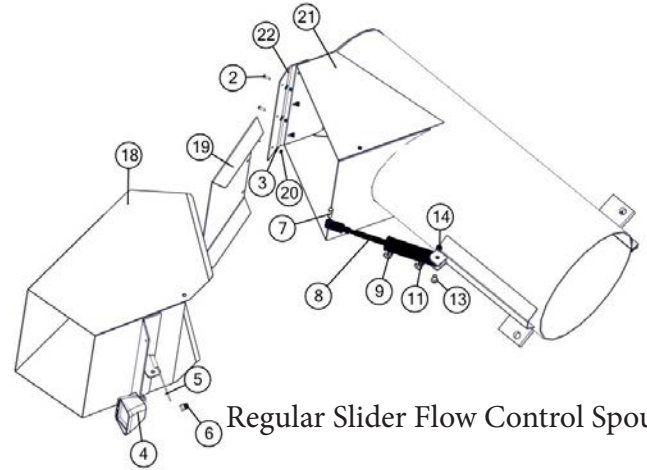

Regular Slider Flow Control Spout

#	Description	Part. No.	#	Description	Part. No.
1	20" Rubber Tip Spout Addition	JM0014420	15	1/2" USS Flat Washer	JM0003082
1	22" Rubber Tip Spout Addition	JM0014129	16	20" Side Shooter Slider Sock	JM0000785
2	1/4"-20 x 1/2" Gr5 Z Hex Bolt	JM0001481	16	22" Side Shooter Slider Sock	JM0017839
3	1/4" USS Flat Washer	JM0003090	17	20" Side Shooter Tip Spout	JM0000781
4	Field Light Assembly	JM0001881	17	22" Side Shooter Tip Spout	JM0017896
5	Mercury Switch	JM0017896	18	20" Regular Slider Tip Spout	JM0026658
6	3/8" Wire Loom	JM0020450	18	22" Regular Slider Tip Spout	JM0026659
7	1/2" x 1-3/4" Pin	JM0018264	19	Baffle Plate for 20" Slider	JM0026660
8	1-3/4" x 4" Hydraulic Cylinder with Rod Clevis and Butt Tab	JM0018564	19	Baffle Plate for 22" Slider	JM0026661
9	1/4" male NPT x 1/4" female NPT rigid; 90 degree elbow	JM0020115	20	1/4"-20 Gr5 Z Centerlock Hex Nut	JM0001505
10	Hydraulic Hose 1/4" x 370"	JM0024908	21	20" Regular Slider Sock	JM0026662
11	1/4" male NPT swivel with .032 orifice	JM0020113	21	22" Regular Slider Sock	JM0026663
12	Hydraulic Hose 1/4" x 370"	JM0024908	22	Hinge for 20" Slider	JM0026664
13	1/2"-13 x 2-1/4" Gr5 Z Hex Bolt	JM0016677	22	Hinge for 22" Slider	JM0026665
14	1/2"-13 Gr5 Z Centerlock Hex Nut	JM0001511	23	Seal Kit for Hydraulic Cylinder	JM0024892

Hydraulic Slider Assembly

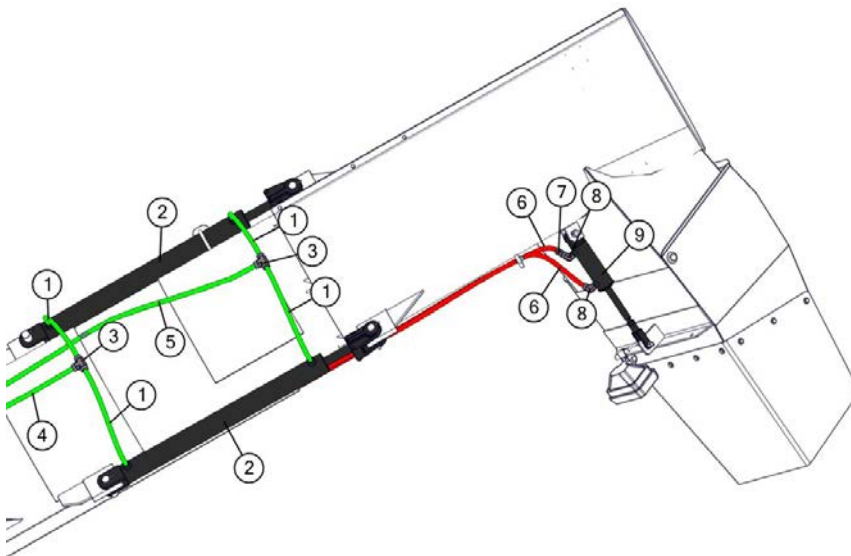

#	Description	Part. No.
1	Hydraulic Hose 1/2" x 16"	JM0024923
2	2" x 24" Stroke Hydraulic Cylinder	JM0018210
3	3/8" male NPT x 1/2" female NPT x 1/2" female NPT; Street T	JM0018266
4	Hydraulic Hose 1/2" x 63"	JM0024922
5	Hydraulic Hose 1/2" x 105"	JM0024924
6	Hydraulic Hose 1/4" x 370"	JM0024908
7	1/4" male NPT swivel with .032 orifice	JM0020113
8	1/4" male NPT x 1/4" female NPT rigid; 90 degree elbow	JM0020115
9	1-3/4" x 4" Hydraulic Cylinder	JM0018564

Lift Cylinder

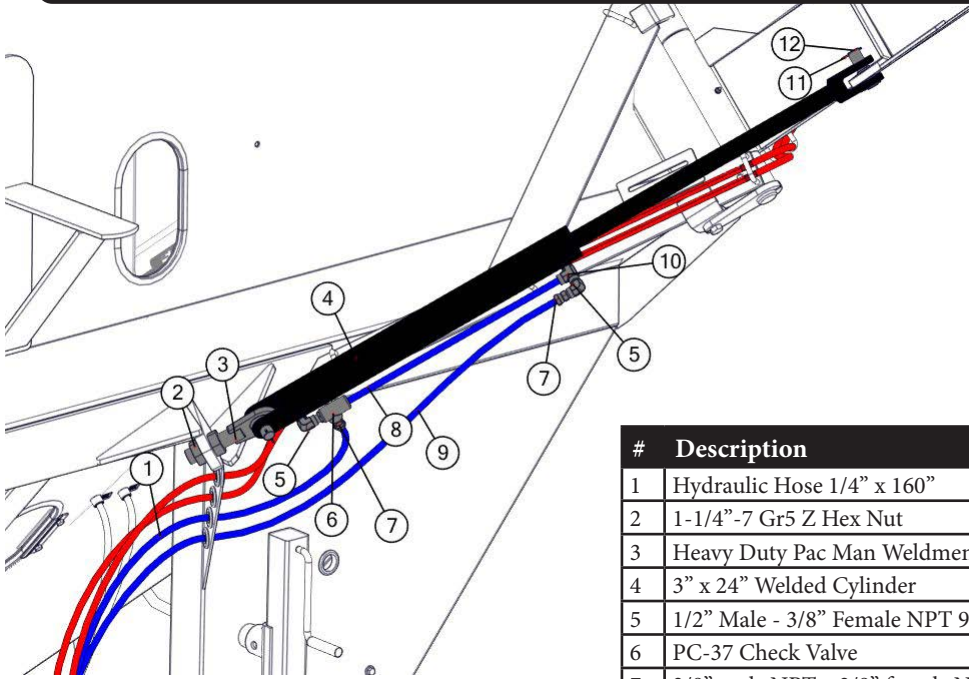

#	Description	Part. No.
1	Hydraulic Hose 1/4" x 160"	JM0024898
2	1-1/4"-7 Gr5 Z Hex Nut	JM0001700
3	Heavy Duty Pac Man Weldment	JM0021417
4	3" x 24" Welded Cylinder	JM0019644
5	1/2" Male - 3/8" Female NPT 90 degree Street Elbow	JM0010292
6	PC-37 Check Valve	JM0018233
7	3/8" male NPT x 3/8" female NPT swivel; WITH .062 orifice	JM0018362
8	Hydraulic Hose 1/4" x 21"	JM0024896
9	Hydraulic Hose 1/4" x 176"	JM0024899
10	3/8" male NPT x 3/8" female NPT x 3/8" female NPT; Street T	JM0018266
11	Cotter Pin	JM0003064
12	1" X 3.40" Clevis Pin	JM0003065

Flow Control Spout

#	Description	Part. No.
1	1/2"-13 x 2" Gr5 Z Hex Bolt	JM0001593
2	1/2"-13 Gr5 Z Centerlock Hex Nut	JM0001511
3	1/4"-20 x 5/8" Gr5 Z Hex Bolt	JM0001479
4	20" Hinge Plate (20" diameter auger)	JM0018583
4	22" Hinge Plate (22" diameter auger)	JM0018582
5	1/4" USS Flat Washer	JM0003090
6	1/4"-20 Gr5 Z Centerlock Hex Nut	JM0001505
7	1/2" x 1-3/4" Pin	JM0018264
8	1/4" x 370" Hydraulic Hose (1050, 1051, 1150, 1151)	JM0024908
9	1/4" male NPT swivel with .032 orifice	JM0020113
10	1/4" male NPT X 1/4" female NPT rigid; 90 degree elbow	JM0020115
11	1/2"-13 x 2" Gr5 Z Hex Bolt	JM0001593
12	20" Baffle Plate (20" diameter auger)	JM0009692
12	22" Baffle Plate (old style) (tapered) (22" diameter auger)	JM0026697
12	22" Baffle Plate (new style) (rectangular) (22" diameter auger)	JM0010977
13	20" Flow Control Spout Housing (20" diameter auger)	JM0018282
13	22" Flow Control Spout Housing (22" diameter auger)	JM0018284
14	Mercury Switch	JM0017896
15	Field Assembly Light	JM0001881
16	3/8" Wire Loom	JM0020450

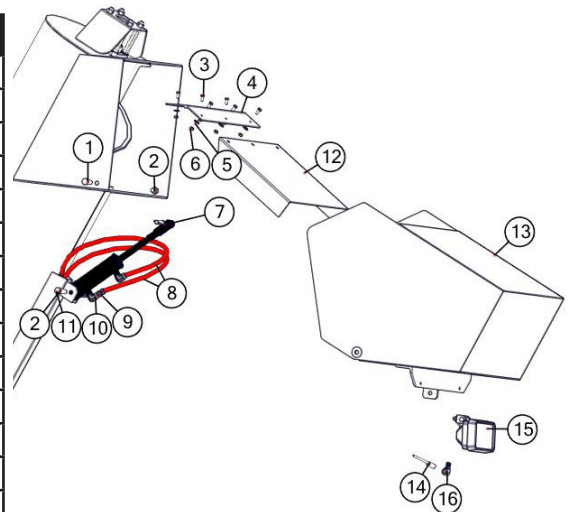

Sideboards

1050

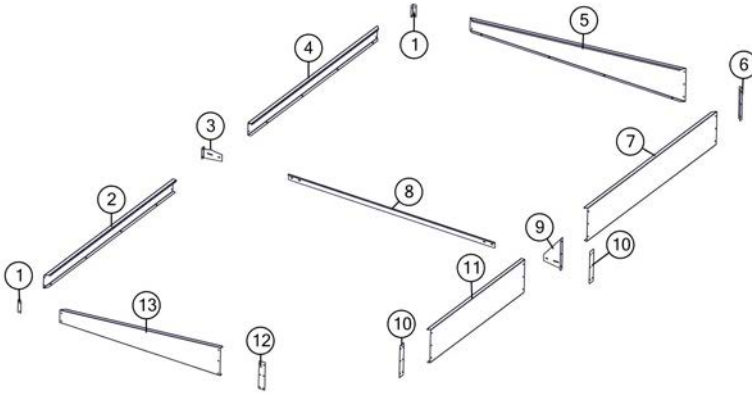

#	Description	Part. No.
1	Low Sideboard Corner	JM0021398
2	1050 GS Low Sideboard (Front)	JM0011029
3	1050 GS Low Sideboard Brace	JM0010921
4	1050 GS Low Sideboard (Back)	JM0011030
5	1050 GS Back Endboard	JM0011025
6	1050 GS Sideboard Corner	JM0010989
7	1050 GS Back Half High Sideboard	JM0011031
8	Sideboard Brace	JM0020624
9	1050 GS High Sideboard Brace	JM0010920
10	1050 GS High Sideboard Splice	JM0010965
11	1050 GS Front Half High Sideboard	JM0011034
12	1050 GS Front Endboard Splice	JM0010966
13	1050 GS Front Endboard	JM0011028

1150

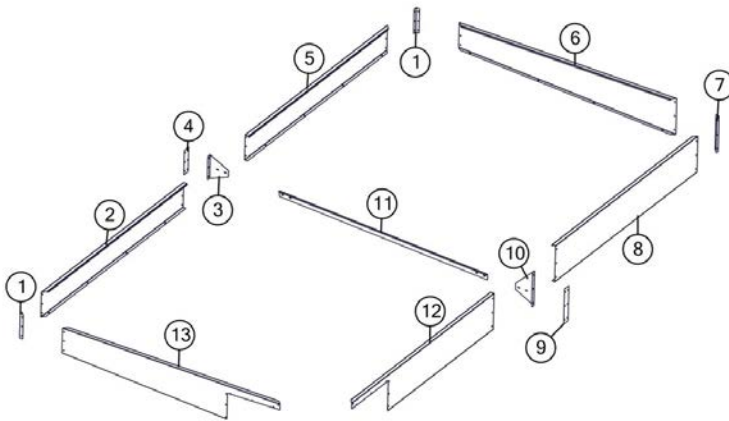

#	Description	Part. No.
1	1150 GS Low Sideboard Corner	JM0015092
2	1150 GS Low Sideboard (Right)	JM0015086
3	1150 GS Low Sideboard Brace	JM0015083
4	1150 GS Low Sideboard Splice	JM0015093
5	1150 GS Low Sideboard (Right)	JM0015087
6	1150 GS Back Endboard	JM0015089
7	1150 GS High Sideboard Corner	JM0015090
8	1150 GS Back Half High Sideboard	JM0015085
9	1150 GS High Sideboard Splice	JM0015091
10	1150 GS High Sideboard Brace	JM0015095
11	Sideboard Brace	JM0020624
12	1150 GS Front Half High Sideboard	JM0015084
13	1150 GS Front Endboard	JM0015088

Miscellaneous

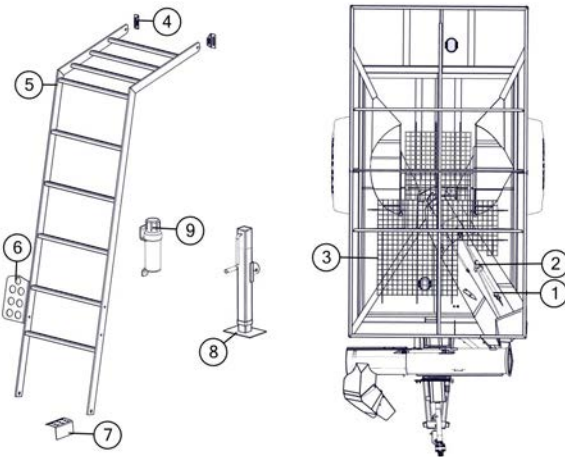

#	Description	Part. No.
1	1/4" x 43" Hydraulic Hose	JM0024904
2	1/2" x 43" Hydraulic Hose	JM0024906
3	Steel Grate	JM0017930
4	Universal Ladder Bracket	JM0016922
5	4 Rung Ladder Platform	JM0018805
6	Hydraulic Hose Holder	JM0012711
7	Frame Rail Step	JM0019030
8	Jack Stand Assembly 7,000 LB	JM0010191
9	Manual Canister	JM0010115
10	40k Lb Safety Chain	JM0029261

To order an upgraded 10K jack you will need to order JM0020936, 2 U-bolts JM0024199, and 4 centerlock nuts JM0002146.

WEIGH SCALE SYSTEMS
Digi-Star 5-Point Scale System
For Single Wheel Applications with Bolt-on Axles

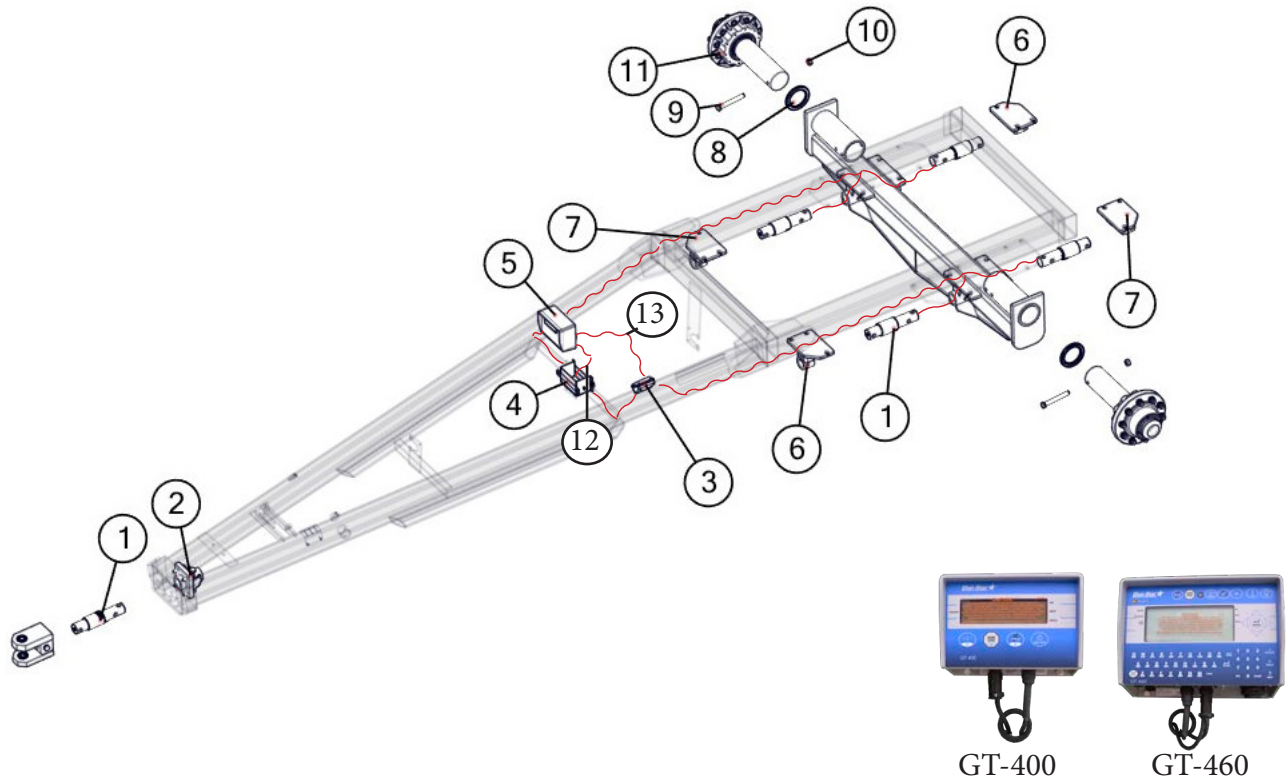

#	Description	Part. No.
1	2-7/8" Weigh Bar, 1" Pin Hole (278WB-T1)	JM0000355
2	Weigh Bar Receiver Weldment Scales 2-7/8" (WBW-278)	JM0000019
3	5 Point Junction Box (JB-5)	JM0019038
4	Battery Box with Strap (BB-2)	JM0000365
5	GT400 Indicator with Serial Port EZ-150, EZ-2000, EZ-400 (GT400)	JM0019040
5	GT 460 Indicator "Upgrade" includes serial port, downloader USB port and alpha-numeric key pad (GT-460)	JM0015453
6	2-7/8" Weigh Bar Weldment, Rear Right, Front Left, Digi-Star	JM0018226
7	2-7/8" Weigh Bar Weldment, Rear Left, Front Right, Digi-Star	JM0018228
8	Seal for Hub (37605SA)	JM0021456
9	1"-8 x 8" Gr5 Z Hex Bolt	JM0001487
10	1"-8 Gr5 Z Centerlock Hex Nut	JM0002149
11	Hub Assembly	-----
12	Power Cord to Battery, Digi-Star (PC-1)	JM0025812
13	30' Standard Cable for J-Box to Indicator (141837)	JM0025820
14	10' Long Extension Cord to Mount Indicator in Cab (ECI-1)	JM0025815
15	20' Long Extension Cord to Mount Indicator in Cab (ECI-2)	JM0025816
16	Optional "Y" Cable to Connect both Printer and Downloader (403037)	JM0025817
17	Flashdrive memory stick-programmed (114991)	JM0025819

WEIGH SCALE SYSTEMS
Digi-Star 5-Point Scale System Hardware
Hardware for Single Wheel and Track System Bolt-on Axles

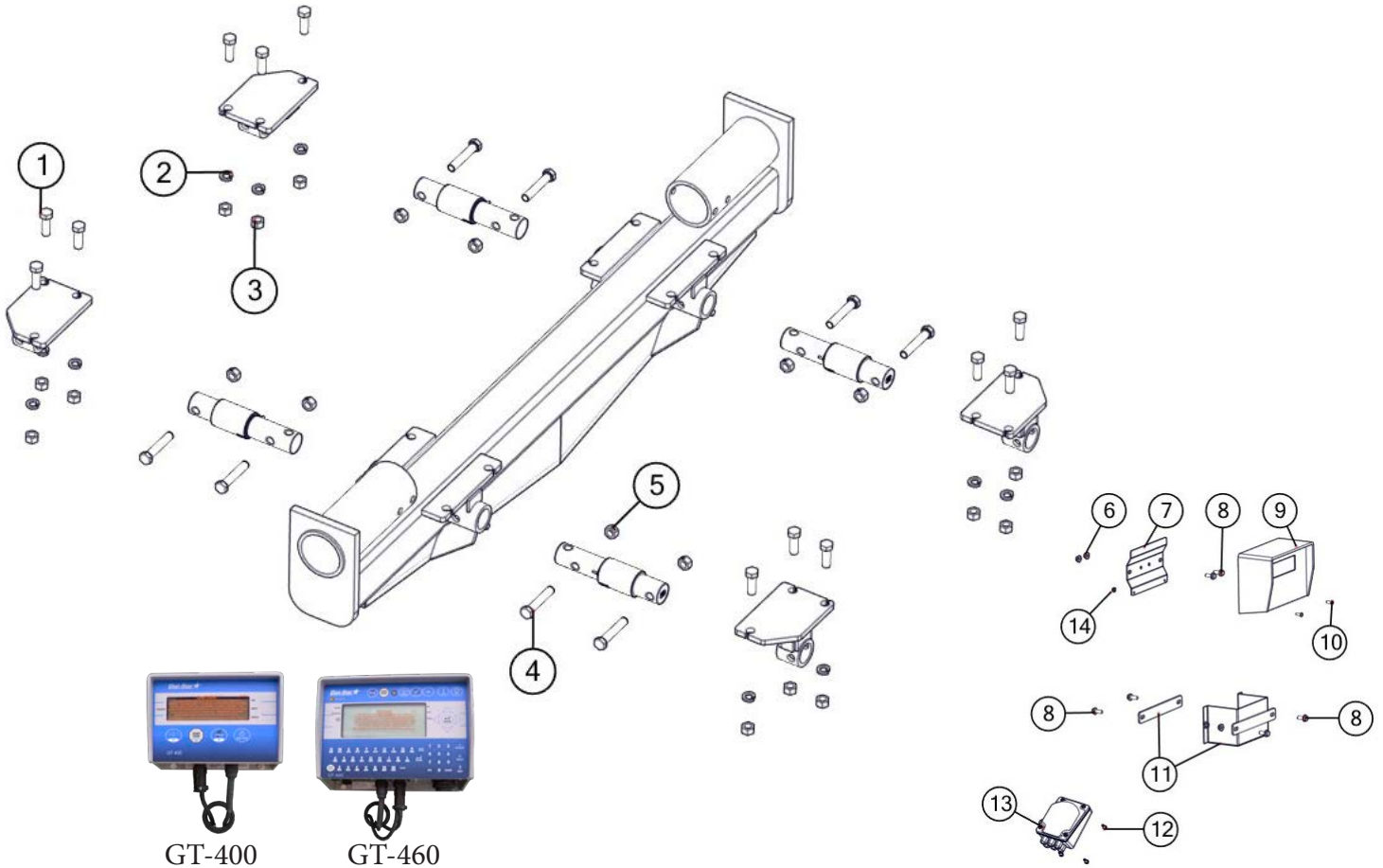

#	Description	Part. No.
1	1"-8 x 3" Gr5 Z Hex Bolt	JM0016686
2	1" Zinc Finish Lock Washer	JM0019203
3	1"-8 Gr5 Z Hex Nut	JM0002127
4	1"-8 x 5-1/2" Gr5 Z Hex Bolt	JM0002110
5	1"-8 Gr5 Z Centerlock Hex Nut	JM0002149
6	3/8"-16 Gr5 Z SF Hex Nut	JM0002152
7	Indicator Mounting Bracket, GT460 (MBI-1)	JM0019648
7	Indicator Mounting Bracket, GT400 (MBI-1S)	JM0000361
8	3/8"-16 x 1" Gr5 Z SF Hex Bolt	JM0002092
9	GT400 Indicator with Serial Port EZ-150, EZ-2000, EZ-400 (GT400)	JM0019040
9	GT 460 Indicator "Upgrade" includes serial port, downloader USB port and alpha-numeric key pad (GT-460)	JM0015453
10	1/4"-20 x 3/4" Gr5 Z Hex Bolt	JM0001507
11	Battery Box with Strap (BB-2)	JM0000365
12	1/4" x 3/4" Self Tapping Screw	JM0001570
13	5 Point Junction Box (JB-5)	JM0019038
14	1/4"-20 Gr5 Z SF Hex Nut	JM0001630

WEIGH SCALE SYSTEMS
Digi-Star & Weigh Tronix Scale System
Walking-Tandem Duals

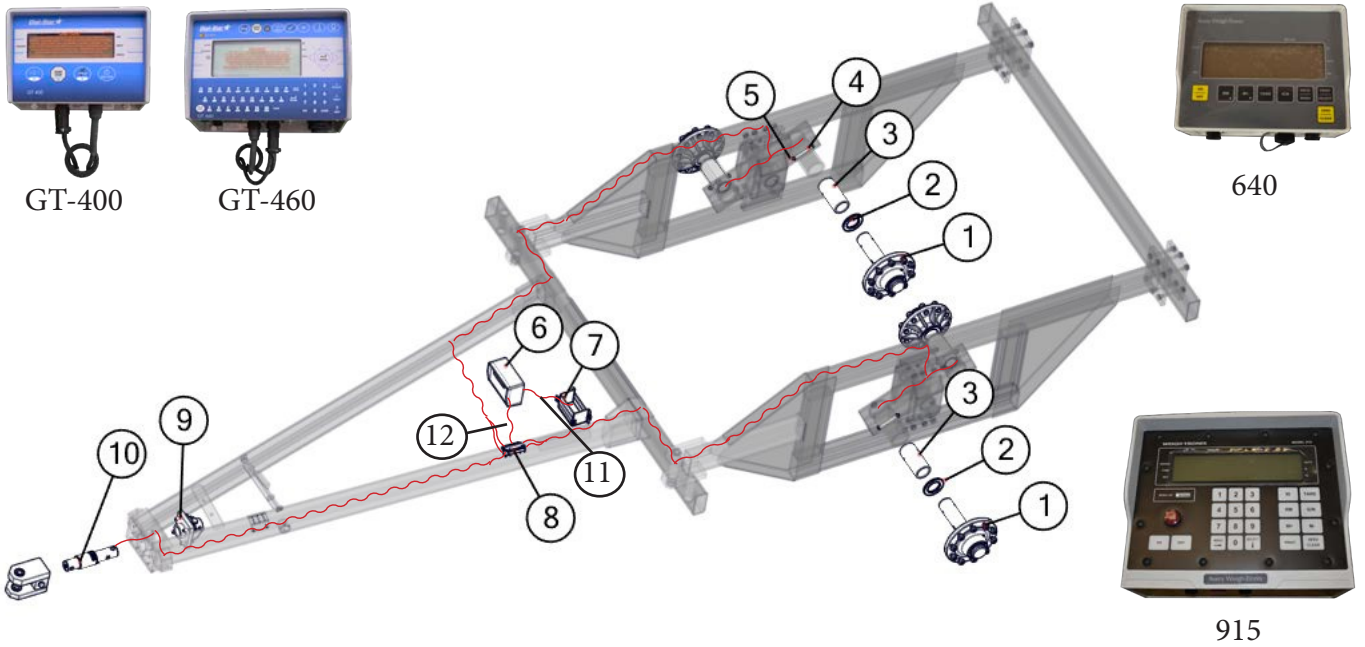

For Models 1050 & 1150 Grain Carts
Digi-Star Scale System

1	3-3/4" Weigh Spindle, Digi Star (375WS)	JM0021451
2	Seal for Hub (37605SA)	JM0021456
3	4-1/2" OD Adapter Pipe Tubing (ATP-375-GS)	JM0021453
4	5/8"-11 x 6-1/2" Gr5 Zinc Hex Bolt	JM0019979
5	5/8"-11 Gr5 Z Centerlock Hex Nut	JM0002146
6	GT400 Indicator with Serial Port EZ-150, EZ-2000, EZ-400 (GT400)	JM0019040
6	GT 460 Indicator "Upgrade" includes serial port, downloader USB port and alpha-numeric key pad (GT-460)	JM0015453
7	Battery Box with Strap (BB-2)	JM0000365
8	5 Point Junction Box (JB-5)	JM0019038
9	Weigh Bar Receiver Weldment Scales 2-7/8" (WBW-278)	JM0000019
10	Digi-Star - 2-7/8" Weigh Bar, 1000-20 through 1501-22, 5 Point Scale System (278WB-T)	JM0000355
11	Power Cord to Battery, Digi Star (PC-1)	JM0025812
12	30' Standard Cable for J-Box to Indicator (141837)	JM0025820
13	Indicator Mounting Bracket, GT460 (MBI-1)	JM0019648
14	Indicator Mounting Bracket, GT400 (MBI-1S)	JM0000361
15	10' Long Extension Cord to Mount Indicator in Cab (ECI-1)	JM0025815
16	20' Long Extension Cord to Mount Indicator in Cab (ECI-2)	JM0025816
17	Optional "Y" Cable to Connect both Printer and Downloader (403037)	JM0025817
18	Flashdrive memory stick-programmed (114991)	JM0025819

WALKING TANDEM DUAL WHEEL ASSEMBLY

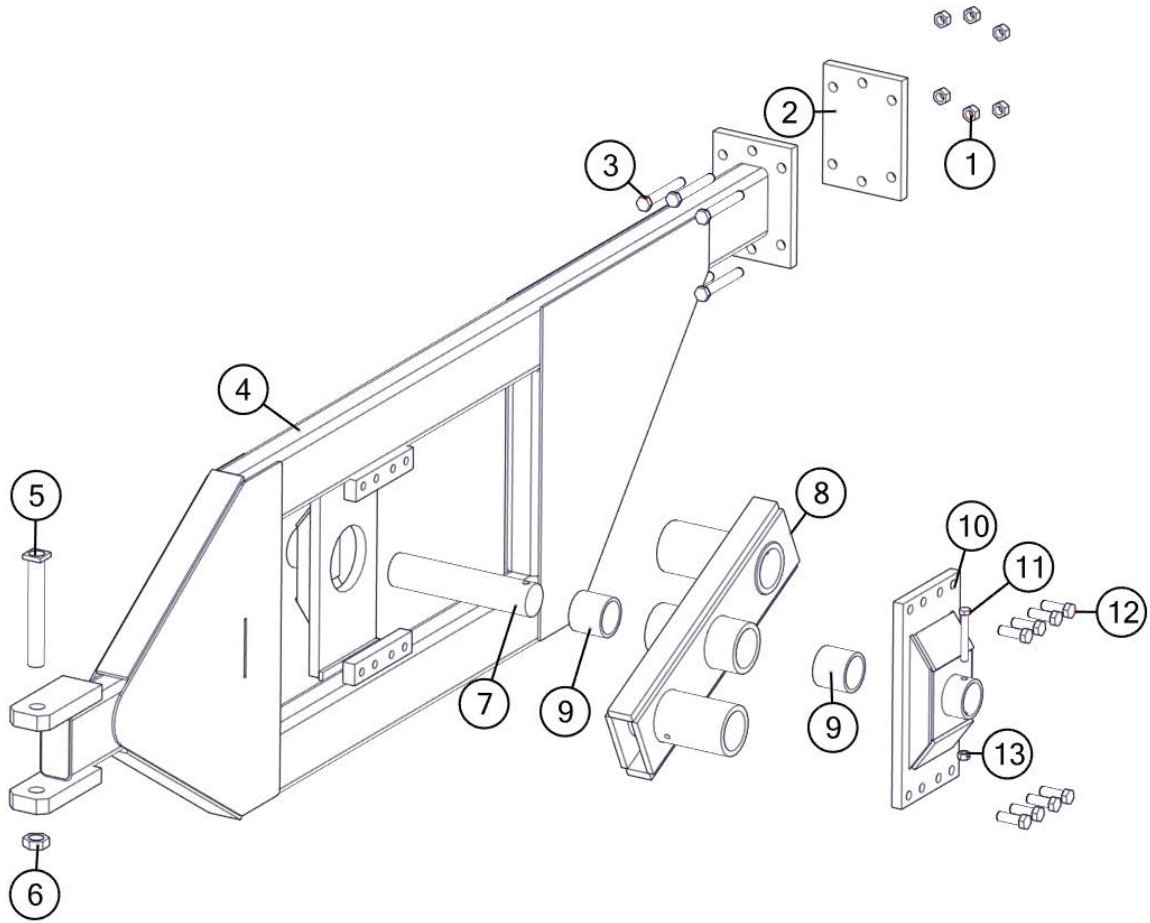

#	Description	Part. No.
1	1"-14 Gr8 YZ Hex Nut (1HNG8)	JM0019926
2	1-1/4" x 8" x 14" Clamp Plate (114814CP)	JM0010145
3	1"-14 x 7-1/2" Gr8 YZ Hex Bolt (1712G8HB)	JM0019925
4	Frame Weldment (Left)(FW-1L)	JM0019922*
4	Frame Weldment (Right)(FW-1R)	JM0010082*
5	1-3/4" x 13-1/2" Bolt (1341312HB)	JM0019981
6	1-3/4"-12 Z Gr5 Hex Jam Nut (134JN)	JM0009752
7	3-3/4" Dia. Pivot Pin (334PP)	JM0019928
8	Pivot Beam Weldment (left)(PBW-1L)	JM0010170*
8	Pivot Beam Weldment (right)(PBW-1R)	JM0010170*
9	3 3/4"ID x 4 1/2"OD Bronze Bushing (BB-334)	JM0010570
10	Pivot Center Weldment (PCW-1)	JM0010076*
11	3/4" x 5 1/2" Grade 5 Bolt (34512G5HB)	JM0015522
12	1"-14 x 3" Grade 8 Bolt (13G8B)	JM0019924
13	3/4" Lock Nut (34-LN)	JM0002147

Door Wheel Assembly (2015 & Older)

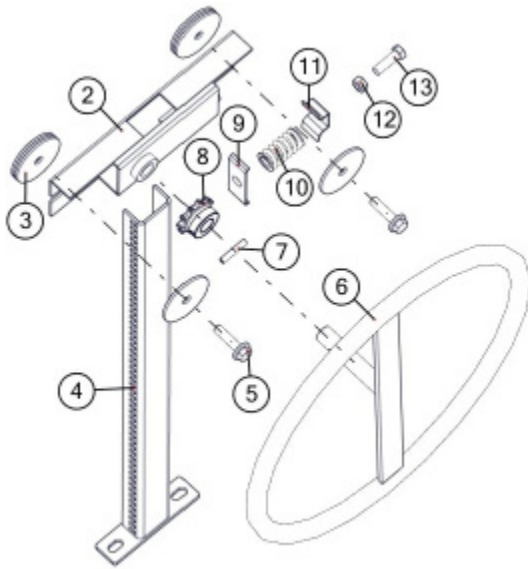

#	Description	Part. No.
1	Complete Door Wheel Assembly (20-1/4")(CWA250)	JM0018884
1	Complete Door Wheel Assembly (28")(CWA750)	JM0018879
2	Welded Guide Assembly (WGA-1034)	JM0018864
3	2-1/2" USS Flat Washer (12-W-212)	JM0018982
4	Track Assembly (20-1/4")(TA-2014)	JM0018861
4	Track Assembly (28")(TA-28)	JM0018860
5	3/8-16 x 1-1/2" Gr5 Z SF Hex Bolt (161200)	JM0001633
6	Wheel Pin & Strap Assembly (WPS-250)	JM0018871
7	1-3/8" Roll Pin (138RP)	JM0009896
8	11 Tooth Sprocket (11T40)	JM0018872
9	Galvanized Clip (GL-250)	JM0002850
10	Spring (DS-250)	JM0001688
11	Metal Clip (MC-250)	JM0002851
12	3/8"-16 Gr5 Z Hex Nut (161850)	JM0001707
13	3/8"-16 x 1-1/4" Gr5 Z Hex Bolt (161160)	JM0016675

Door Wheel Assembly (2016 & Newer)

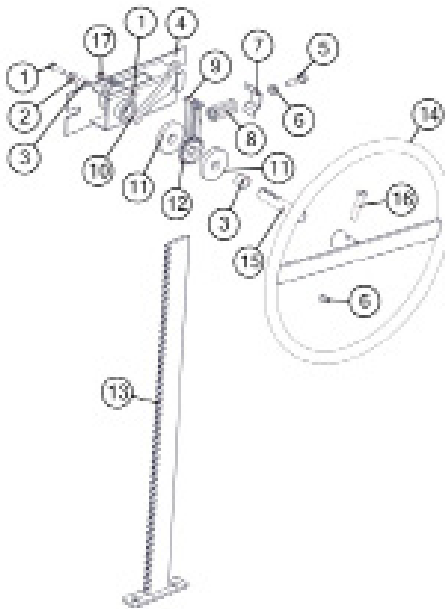

#	Description	Part. No.
1	1/4"-20 x 1" Gr5 Z Hex Bolt (141G5B)	JM0002095
2	1/4" USS Flat Washer (14-W)	JM0003090
3	.754 ID x .874 OD x .625 LG Bronze Bushing (BB-34)	JM0009455
4	Nylon Guided Rack Housing Weldment	JM0030635
5	3/8"-16 x 1-1/4" Gr5 Z Hex Bolt (161160)	JM0016675
6	3/8"-16 Gr5 Z Hex Nut	JM0001707
7	Rack Track Guide (Scrubber Plate) (MC-250)	JM0002851
8	Small Compression Spring (DS-250)	JM0001688
9	Nylon Track Guide	JM0029354
10	Flip Lock	JM0029459
11	Keyway Washer	JM0029454
12	15 Tooth Sprocket - 3/4" Bore w/ Key	JM0029455
13	Nylon Guided Rack Track 20-1/4" Weldment	JM0030651
13	Nylon Guided Rack Track 27-1/2" Weldment	JM0030634
14	Rack Wheel Weldment	JM0028898
15	Stub Shaft - 3/4" x 4-1/8" with Threaded End	JM0029440
16	Complete Nylon Door Wheel Assembly (20-1/4")	JM0030652
16	Complete Nylon Door Wheel Assembly (27-1/2")	JM0029460

Inspection Windows

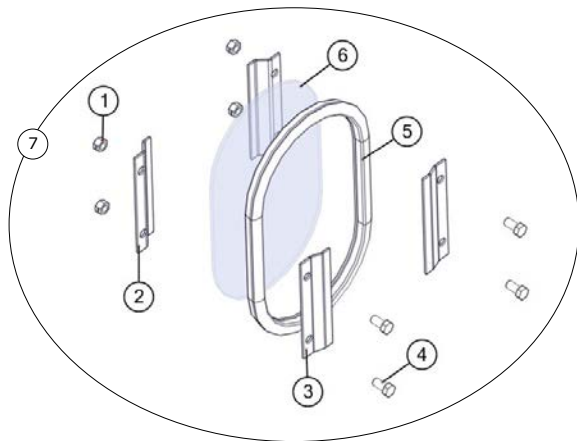

#	Description	Part. No.
1	3/8"-16 Gr5 Z Centerlock Hex Nut (161900)	JM0001512
2	Inside Window Brace (WB-4)	JM0000253
3	Outside Window Brace (WB-4B)	JM0000256
4	3/8-16 x 3/4" Gr5 Z Hex Bolt (161000)	JM0001663
5	Oval Window Grommet (112500)	JM0002454
6	Oval Window (IW-71212)	JM0002455
7	Inspection Window Kit (IWK-1)	JM0025752

Light Kit Assembly

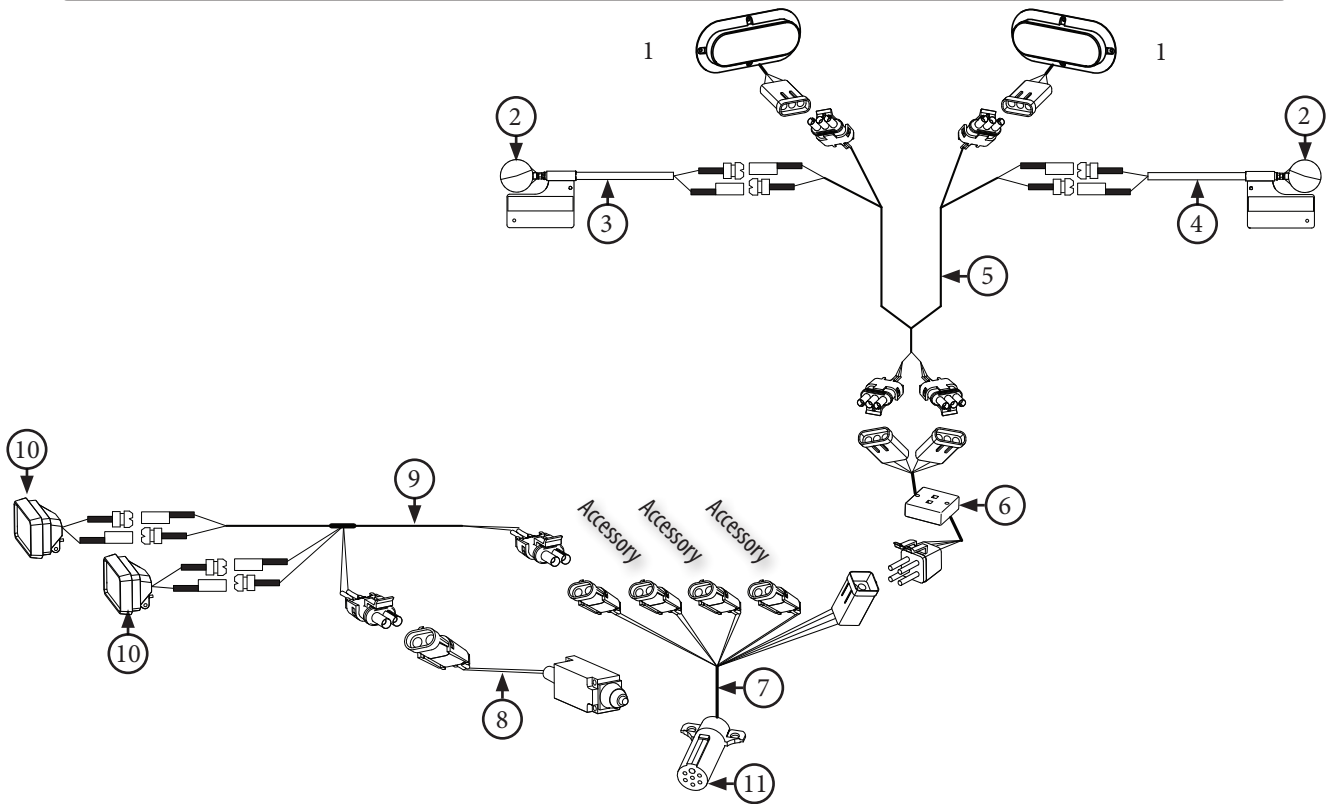

#	Description	Part. No.
1	Red Light (LED)	JM0034389
2	Amber Light Only	JM0018819
3	Extendable Amber Light Assembly (Left Side)	JM0018817
4	Extendable Amber Light Assembly (Right Side)	JM0018826
5	Wiring Harness for Rear Lights (Each)	JM0020437
6	Light Enhancer	JM0010566
7	Main Wiring Harness with 7-Prong Connector End	JM0020439
8	Limit Switch (for field light)	JM0036040
9	Field Light Wire	JM0020438
10	Field Light (LED, Grain Cart)(Bullet Lead Ends)	JM0000881
11	7-Prong Connector End Only	JM0010528

Roll Tarp Assembly

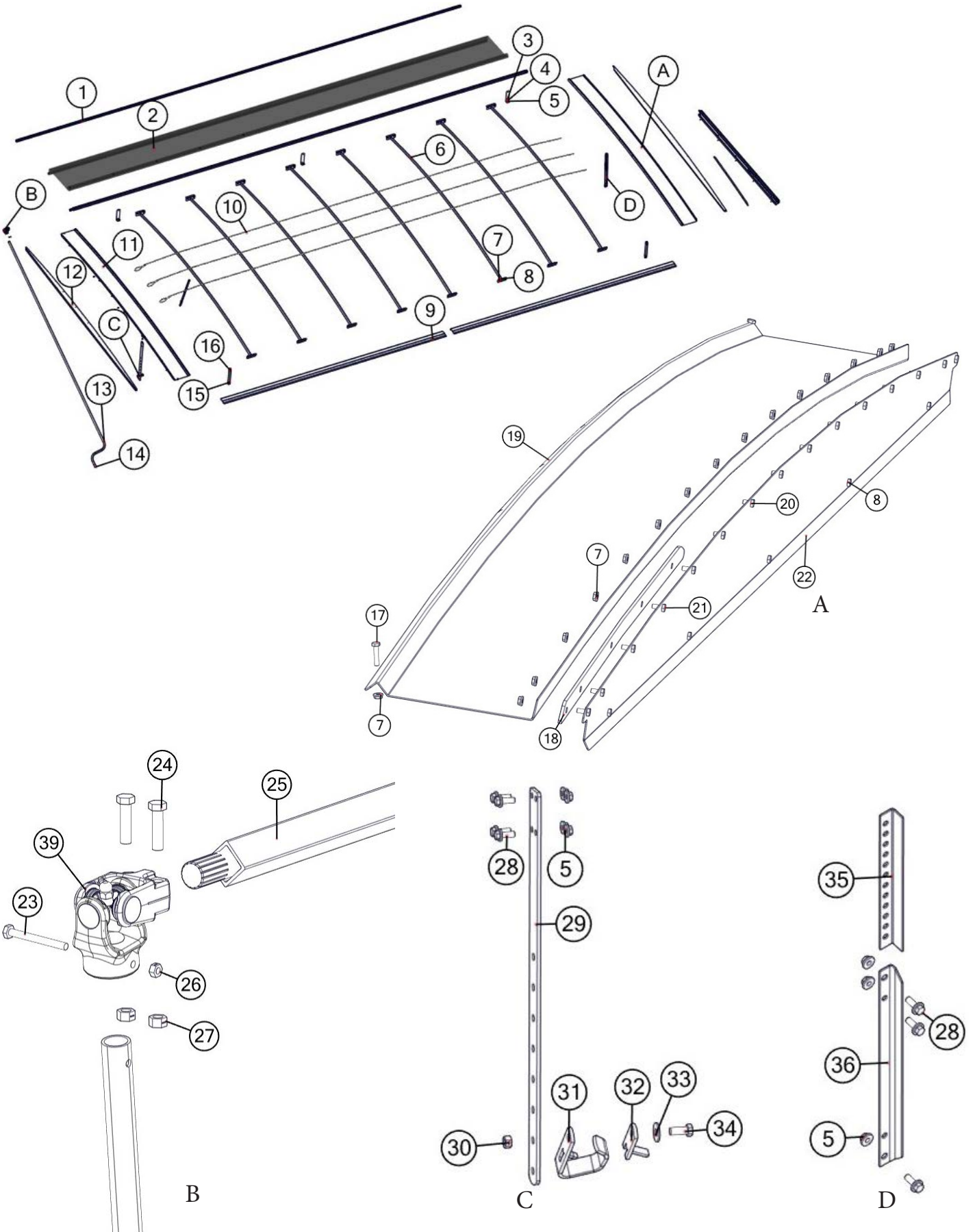

Roll Tarp Assembly

#	Description	Part. No.	#	Description	Part. No.
1	1" Square Tie-Down Tube (1050 through 1151)	JM0021331	20	1/4"-20 x 1/2" Gr5 Z Hex Bolt	JM0001481
2	Tarp with Rivets (1050 through 1151)	JM0021336	21	1/4"-20 x 5/8" Gr5 Z Hex Bolt	JM0001479
3	Tarp Stop Bracket	JM0000187	22	Front End Cap Plate (1050 through 1151)	JM0000194
4	3/8"-16 x 2" Gr5 Z Hex Bolt	JM0001510	23	1/4"-20 x 2-1/2" Gr5 Z Hex Bolt	JM0001506
5	3/8"-16 Gr5 Z SF Hex Nut	JM0002152	24	3/8"-16 x 1-1/2" Gr5 Z Hex Bolt	JM0001659
6	Arched Tarp Bows (1050 through 1151)	JM0000157	25	1 1/4" Square Roll Tube (1050 through 1151)	JM0021334
7	1/4"-20 Gr5 Z SF Hex Nut	JM0001630	26	1/4"-20 Gr5 Z Centerlock Hex Nut	JM0001505
8	1/4"-20 x 3/4" Gr5 Z Hex Bolt	JM0001507	27	3/8"-16 Gr5 Z Centerlock Hex Nut	JM0001512
9	Tightening Lip (1050 through 1151) Front	JM0013654	28	3/8"-16 x 1" Gr5 Z SF Hex Bolt	JM0002092
9	Tightening Lip (1050 through 1151) Rear	JM0013653	29	Crank Holder	JM0000164
10	3/16" Cable (1050 through 1151)	JM0021408	30	1/2"-13 Gr5 Z Centerlock Hex Nut	JM0001511
11	Rear Arched End Cap (1050 through 1151)	JM0000172	31	Roll Tarp - Handle Hanger PP	JM0002967
12	Rear End Cap Plate (1050 through 1151)	JM0000169	32	Roll Tarp - Handle Hanger Rubber Flap	JM0002551
13	Crank with Splined U-Joint (1050 through 1151)	JM0019888	33	1/2" USS Flat Washer	JM0003082
14	Yellow Cap	JM0018963	34	1/2"-13 x 1-1/4" Gr5 Z Hex Bolt	JM0001513
15	Tarp Standoff	JM0001889	35	Upper Adjustable Bow Support 13"	JM0021404
16	1/4" x 1-1/2" Self Tapping Screw	JM0001571	36	Lower Adjustable Bow Support 27" (1050, 1151)	JM0021403
17	1/4"-20 x 1-1/4" Gr5 Z Hex Bolt	JM0016673	37	3/8"-16 Gr5 Z J-Bolt	JM0001519
18	Tarp Nylon Riser	JM0000196	38	Cable Clamp-Small	JM0001514
19	Front Arched End Cap (1050 through 1151)	JM0000195			

Spring Return Assembly

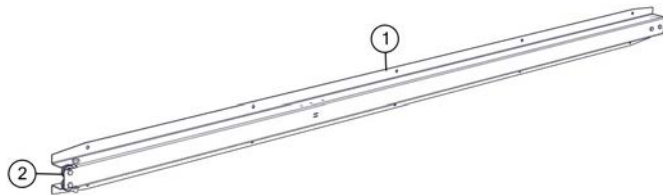

#	Description	Part. No.
1	Spring Return Assembly	JM0012965
2	Spring Return Cable	JM0012981

Auto-Log Kit

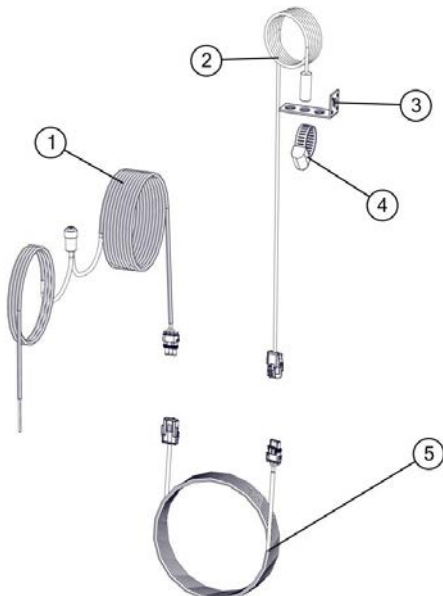

#	Description	Part. No.
1	Auto-Logger 25' Wire Bundle	JM0015445
2	Rotation Counter Sensor Wire bundle	JM0015447
3	Rotation Counter Mounting Bracket	JM0015448
4	Steel Sensor Target Screw Clamp	JM0015450
5	Rotation Counter Sensor Extension Wire Bundle	JM0015452

Service / Maintenance Record

Date	Description	Notes

For any service instructions, visit our website at www.jm-inc.com