

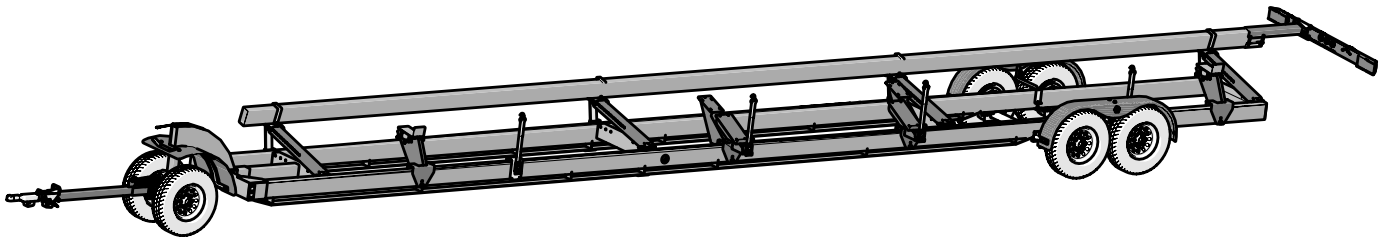

# Operator's Manual

**TRAIL-BLAZER**  
HEADER TRANSPORT



Rev. 5.4.2023

J&M Manufacturing Co, Inc

284 Railroad Street - P.O. Box 547 | Fort Recovery, OH 45846 | Ph: (419) 375-2376 | Fax: (419) 375-2708

[www.jm-inc.com](http://www.jm-inc.com)



# Table Of Contents

To the Dealer .....	4
General Information .....	5
Safety Rules .....	6
Dimensions & Specifications.....	7
Decals .....	8
Bolt Torque Specifications .....	9
Stud and Wheel Nut Torque Specifications .....	9
Operations/Maintenance.....	10
Torsion Dolly.....	12
TB-7000 Dolly Hubs .....	13
TB-7000 Rear Axles.....	14
Header Mounts .....	16
Tie-Down.....	17
Lifting Arms & Props .....	17
Front Fender.....	18
Fender.....	19
Upper Bar.....	20
Wire Conduit.....	20
Lights and Wiring on Pivoting Lightbar- Ag, No Brakes.....	22
Lights and Wiring on Pivoting Lightbar- Ag, with Brakes.....	23
Lights and Wiring on Pivoting Lightbar- Highway, Brakes .....	24



# To the Dealer

## TO THE DEALER

Read manual instructions and safety rules. Make sure all items on the Dealer's Pre-Delivery and Delivery Check Lists are completed before releasing equipment to the owner.

The dealer must complete the Warranty Registration found on the Dealer Portal website located at dealer.jm-inc.com and return it to J&M Mfg. Co., Inc. at the address indicated on the form. Warranty claims will be denied if the Warranty Registration has not been submitted.

### EXPRESS WARRANTY:

J&M Mfg. Co. Inc. warrants against defects in construction or materials for a period of ONE year. We reserve the right to inspect and decide whether material or construction was faulty or whether abuse or accident voids our guarantee.

Warranty service must be performed by a dealer or service center authorized by J&M Mfg. Co., Inc. to sell and/or service the type of product involved, which will use only new or remanufactured parts or components furnished by J&M Mfg. Co., Inc. Warranty service will be performed without charge to the purchaser for parts or labor based on the Warranty Labor Times schedule. Under no circumstance will allowable labor times extend beyond the maximum hours indicated in the Warranty Labor Times schedule for each warranty procedure. The purchaser will be responsible, however, for any service call and/or transportation of the product to and from the dealer or service center's place of business, for any premium charged for overtime labor requested by the purchaser, and for any service and/or maintenance not directly related to any defect covered under the warranty. Costs associated with equipment rental, product down time, or product disposal are not warrantable and will not be accepted under any circumstance.

Each warranty term begins on the date of product delivery to the purchaser. Under no circumstance will warranty be approved unless (i) the product warranty registration card has been properly completed and submitted to the equipment manufacturer, and (ii) a warranty authorization number has been issued by the equipment manufacturer. This Warranty is effective only if the warranty registration card is returned within 30 days of purchase.

This warranty does not cover a component which fails, malfunctions or is damaged as a result of (i) improper modification or repair, (ii) accident, abuse or improper use, (iii) improper or insufficient maintenance, or (iv) normal wear or tear. This warranty does not cover products that are previously owned and extends solely to the original purchaser of the product. Should the original purchaser sell or otherwise transfer this product to a third party, this warranty does not transfer to the third party purchaser in any way. J&M Mfg. Co., Inc. makes no Warranty, express or implied, with respect to tires or other parts or accessories not manufactured by J&M Mfg. Co., Inc. Warranties for these items, if any, are provided separately by their respective manufacturers.

THIS WARRANTY IS EXPRESSLY IN LIEU OF ALL OTHER WARRANTIES OR CONDITIONS, EXPRESS, IMPLIED OR STATUTORY, INCLUDING ANY IMPLIED WARRANTY OF MERCHANTABILITY OR FITNESS FOR PARTICULAR PURPOSE.

In no event shall J&M Mfg. Co., Inc. be liable for special, direct, incidental or consequential damages of any kind. The exclusive remedy under this Warranty shall be repair or replacement of the defective component at J&M Mfg. Co., Inc.'s option. This is the entire agreement between J&M Mfg. Co., Inc. and the Owner about warranty and no J&M Mfg. Co., Inc. employee or dealer is authorized to make any additional warranty on behalf of J&M Mfg. Co., Inc.

The manufacturer reserves the right to make product design and material changes at any time without notice. They shall not incur any obligation or liability to incorporate such changes and improvements in products previously sold to any customer, nor shall they be obligated or liable for the replacement of previously sold products with products or parts incorporating such changes.

### SERVICE:

The equipment you have purchased has been carefully manufactured to provide dependable and satisfactory use. Like all mechanical products, it will require cleaning and maintenance. Lubricate the unit as specified. Observe all safety information in this manual and safety signs on the equipment.

For service, your authorized J&M dealer has trained mechanics, genuine J&M service parts, and the necessary tools and equipment to handle all your needs.

Use only genuine J&M service parts. Substitute parts may void warranty and may not meet standards required for safety and satisfactory operation. Record the model number and serial number of your equipment in the spaces provided:

**Model No:** TB-6000H or TB-8000H **Serial No:** \_\_\_\_\_ **Date of Purchase:** \_\_\_\_\_

**Purchased From:** \_\_\_\_\_

Provide this information to your dealer to obtain correct repair parts.



# General Information

## TO THE OWNER:

The purpose of this manual is to assist you in operating and maintaining your header transport in a safe manner. Read it carefully. It furnishes information and instructions that will help you achieve years of dependable performance and help maintain safe operating conditions. If this machine is used by an employee or is loaned or rented, make certain that the operator(s), prior to operating:

1. Is instructed in safe and proper use.
2. Reviews and understands the manual(s) pertaining to this machine.

Throughout this manual, the term **IMPORTANT** is used to indicate that failure to observe can cause damage to equipment. The terms **CAUTION**, **WARNING** and **DANGER** are used in conjunction with the Safety-Alert Symbol, (a triangle with an exclamation mark), to indicate the degree of hazard for items of personal safety. When you see this symbol, carefully read the message that follows and be alert to the possibility of personal injury or death.



This Safety-Alert symbol indicates a hazard and means **ATTENTION! BECOME ALERT! YOUR SAFETY IS INVOLVED!**



**DANGER**

Indicates an imminently hazardous situation that, if not avoided, will result in death or serious injury.



**WARNING**

Indicates a potentially hazardous situation that, if not avoided, could result in death or serious injury, and includes hazards that are exposed when guards are removed.



**CAUTION**

Indicates a potentially hazardous situation that, if not avoided, may result in minor or moderate injury.

**IMPORTANT**

Indicates that failure to observe can cause damage to equipment.

**NOTE**

Indicates helpful information.

## SAFETY RULES:

 **ATTENTION! BECOME ALERT! YOUR SAFETY IS INVOLVED!** 

Safety is a primary concern in the design and manufacture of our products. Unfortunately, our efforts to provide safe equipment can be erased by an operator's single careless act. In addition, hazard control and accident prevention are dependent upon the awareness, concern, judgment, and proper training of personnel involved in the operation, transport, maintenance and storage of equipment.

Make certain that the operator(s), prior to operating is instructed in safe and proper use and reviews and understands the manual(s) pertaining to this machine. Also make certain that the operator(s) reviews and understands the operator's manual of the tow vehicle prior to hooking up or operating the SpeedTender.

Read this manual before you operate this machine. If you do not understand any part of this manual, or need more information, contact the J&M or your authorized dealer.

**Safety Rules Continued on Next Page**

# Safety Rules

1. Understand that your safety and the safety of other persons are measured by how you service and operate this machine. Know the positions and functions of all controls before you try to operate them. Check all controls in a safe area before starting your work.
2. The safety information given in this manual does not replace safety codes, federal, state, or local laws. Ensure your machine has the proper equipment as designated by local laws and regulations.
3. A frequent cause of personal injury or death is from persons falling off equipment and being run over. Do not permit persons to ride on this machine.
4. Secure safety chain to towing vehicle before transporting. Do not transport without safety chains being attached to tow vehicle.  
**IMPORTANT: USE ONLY 2-5/16" BALL HITCH TO TRANSPORT UNIT.**
5. Use good judgment when transporting on a highway. Always maintain complete control. Regulate speed to road conditions.  
**WARNING: BE SURE ALL LIGHTS ARE WORKING PROPERLY BEFORE HIGHWAY TRAVEL.**
6. Travel speeds should be such that complete control and machine stability is maintained at all times.
7. Where possible, avoid operating near ditches, embankments and holes. Reduce speed when turning, crossing slopes and rough, slick or muddy surfaces.
8. Make sure that the header is fastened securely to the transport before moving.
9. Make sure that everyone is clear of equipment before applying power or moving the machine. NEVER position yourself under or near header when mounting on header transport.
10. Never adjust, service, clean or lubricate the header transport until all power is shut off.
11. Ensure the implement is fastened securely to the towing unit.
12. Before unhooking the implement from the towing unit, properly block the wheels to prevent the implement from moving.
13. Never overload the header transport. Overloading the header transport is dangerous and can cause extensive damage.
14. Use caution when transporting. Be alert of the transport unit's overall width when approaching obstacles, such as post signs and poles, along the road. Check the transport width of the unit to ensure clearance before entering bridges.
15. COMPLY WITH ALL SAFETY WARNINGS AND CAUTIONS IN THIS MANUAL AND IN THE COMBINE OPERATOR'S MANUAL.

# Dimensions & Specifications

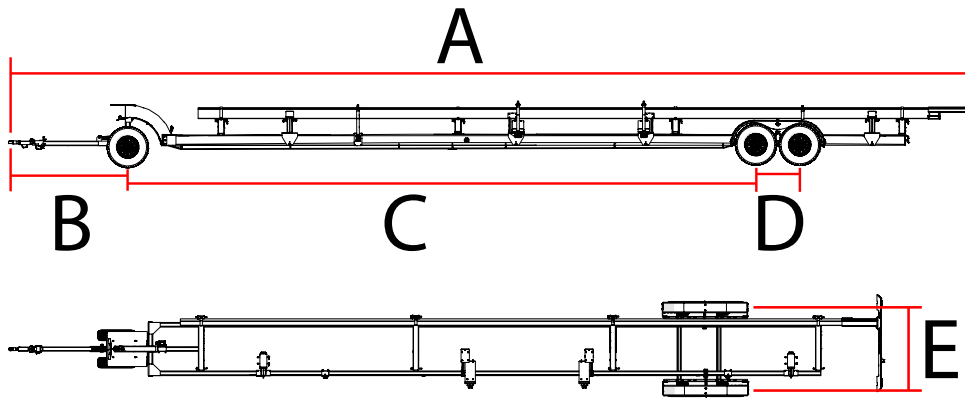

	TB-7000A-HD-48	TB-7000A-HD-52	TB-7000H-HD-48	TB-7000H-HD-52
A	63'-3"	64'-6"	63'-3"	64'-6"
B	6'-0"			
C	40'-7"			
D	2'-10"			
E	6'-0"			

	TB-7000A-HD-48	TB-7000A-HD-52	TB-7000H-HD-48	TB-7000H-HD-52
Weight	6,620 lbs.	6,770 lbs.	6,620 lbs.	6,770 lbs.
Capacity (Net)	19,516 lbs.	19,366 lbs.	17,140 lbs.	16,990 lbs.
Spindle Size Front	(2) 2-1/4" Diameter			
Spindle Size Back	(4) 2-1/2" Diameter			
Wheel Size	16" x 6" - 8 Bolt			
Tire Size	235/85R16F			
Steel Upper Bar	4" x 8" x 3/16" Steel Tubing			
Upper Bar Length	48'	52"	48'	52"
Arched Main Frame	4" x 8" x 3/8" Tubing			
Rear Electric Brakes	Optional	Optional	Standard	Standard
Deluxe Light Package	√	√	√	√

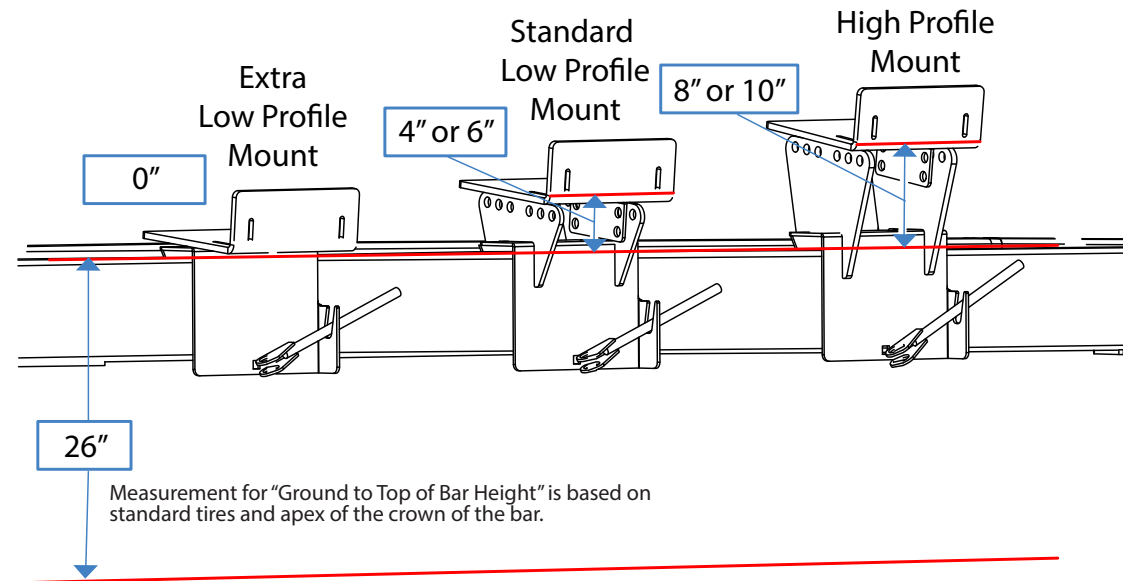

# Decals

**⚠ ATTENTION! BECOME ALERT! YOUR SAFETY IS INVOLVED! ⚠**  
 Replace Immediately If Damaged or Missing

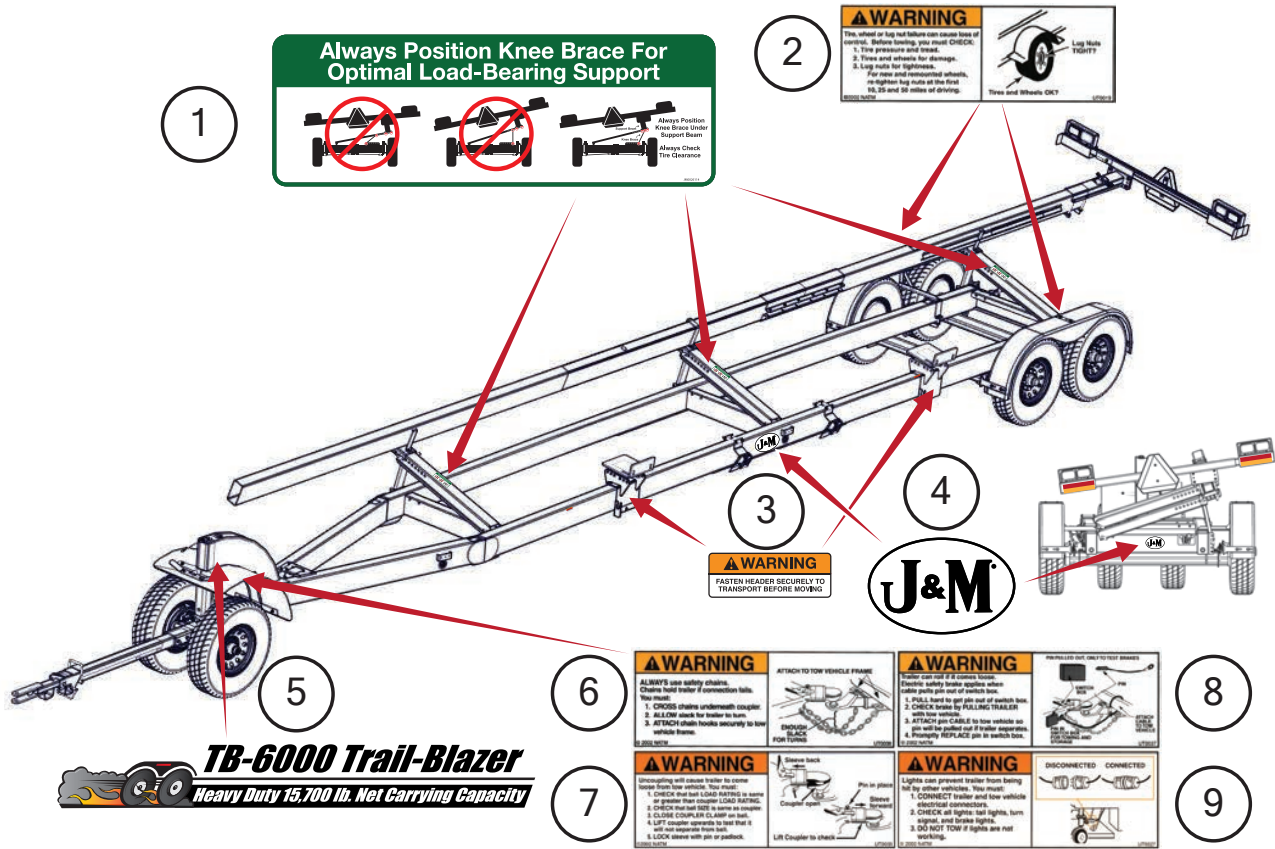

**TB-6000 Trail-Blazer**  
 Heavy Duty 15,700 lb. Net Carrying Capacity

Description	Part No.
1 HT - Knee Brace Set Up Decal	JM0026114
2 Warning, Tire Wheel or Lug Nut Failure Decal	JM0014996
3 Warning - Fasten Header Securely To Transport Before Moving Decal	JM0039381
4 J&M Oval Decal (Small) 3-5/8" x 5-1/4"	JM0015150
5 TB-6000 Decal	JM0040063
6 Warning, Always Use Safety Chains Decal	JM0014995
7 Warning, Uncoupling Will Cause Trailer Decal	JM0058889
8 Warning, Trailer Can Roll Decal	JM0014997
9 Warning, Lights Can Prevent Decal	JM0058890





# Bolt Torque Specifications

Always tighten hardware to these values unless a different torque or tightening procedure is listed for specific application. Fasteners must always be replaced with the same grade as specified in the manual parts list. Always use the proper tool for tightening hardware. Make sure fastener threads are clean and you start thread engagement properly. **Use these values when tightening all bolts and nuts with the exception of wheel nuts.**

## SAE Fasteners

Coarse Thread Series				
Diameter and Pitch (Inches)	Grade 5		Grade 8	
	Dry	Oiled	Dry	Oiled
1/4"-20	8 ft-lbs	6 ft-lbs	12 ft-lbs	9 ft-lbs
5/16"-18	17	13	25	18
3/8"-16	31	23	44	33
7/16"-14	49	37	70	52
1/2"-13	75	57	106	80
9/16"-12	109	82	154	115
5/8"-11	150	113	212	159
3/4"-10	267	200	376	282
7/8"-9	429	322	606	455
1"-8	644	483	909	681
Fine Thread Series				
Diameter and Pitch (Inches)	Grade 5		Grade 8	
	Dry	Oiled	Dry	Oiled
1/4"-28	10 ft-lbs	7 ft-lbs	14 ft-lbs	10 ft-lbs
5/16"-24	19	15	27	20
3/8"-24	35	26	49	37
7/16"-20	55	41	78	58
1/2"-20	85	64	120	90
9/16"-18	121	91	171	128
5/8"-18	170	127	240	180
3/4"-16	297	223	420	315
7/8"-14	474	355	669	502

## Stud and Wheel Nut Torque Specifications

Always tighten hardware to these values unless a different torque or tightening procedure is listed for specific application. Fasteners must always be replaced with the same grade as specified in the manual parts list. Always use the proper tool for tightening hardware. Make sure fastener threads are clean and you start thread engagement properly. **Use these values when tightening all studs and wheel nuts.**

Stud	Tightening Torque
1/2"-20	120 ft-lbs
9/16"-18	170 ft-lbs
5/8"-18	350 ft-lbs
3/4"-16	400 ft-lbs
20mm	475 ft-lbs
22mm	640 ft-lbs

**TIGHTENING WHEEL NUTS:** Torque 9/16"-18 lug nuts on wheels to 170 ft-lbs during initial operation of the header wagon. Check for proper torque after every 10 hours of use. Failure to do so may damage wheel nut seats. Once seats are damaged it will become impossible to keep nuts tight.

# Operations/Maintenance

 **DANGER: BE CERTAIN THAT ALL POWER IS SHUT OFF BEFORE SERVICING THE HEADER TRANSPORT.**

## **Before the Header Transport is Put into Service:**

- Has the Slow-Moving Vehicle sign been properly positioned at the rear of the header transport?
- Have all danger, warning, caution and important signs on the equipment been read and understood? If employees or others use or are near this equipment, make sure that they also have read and understood all danger, warning, caution and important signs on the equipment and have also read the operator's manual.
- Are all braces, bolts, nuts, studs and lug nuts properly fastened?
- Has the header transport been properly fastened to the towing unit? Use a good quality hitch pin with clip and safety chains.
- Are the rear amber extremity lights properly positioned? Extend lights within 16" of the left and right extremities of the header.

## **Safety Chain User Instructions**

- Secure the safety chain by looping it around the tongue support located on the underside of the hitch tongue and connect to the towing machine's attaching bar.
- Do not allow more slack than necessary for articulation.
- Do not use an intermediate support as the attaching point.
- Store the safety chain by securing it around the tongue.
- Replace the safety chain if one or more links or end fittings are broken, stretched or otherwise damaged or deformed.

 **WARNING: Check safety chains for broken, stretched or damaged link or end fittings. Replace chains if found to be damaged. Do not weld safety chains.**

## **Operating Instructions/Maintenance**

- Adjust the brackets on the header transport to best fit your make and model header.  
**Note: When mounting the header, NEVER position yourself under or near the header. Securely fasten the header to the header transport.**
- Do not exceed the load and size limits of the unit.
- Keep the tires properly inflated. Both under inflation and over inflation can greatly reduce tire life. Inflate 235-85 R16 tires to 80 psi.
- Inspect bracing and welds periodically and repair immediately, if needed. Failure to repair could cause extensive damage and greatly reduce the life of the unit.
- Repack the bearings in the hub assembly once a year or as needed. Use a good quality LS EP2 severe duty, high shock load, lithium-based grease.
- Grease the ball using the zerk on the front gooseneck assembly every 8 hours or as needed.
- Check the wheel nuts often and keep them properly tightened.

## **Braking System Requirements**

- Stopping distance increases with speed and weight of towed loads and on slopes. Towed loads with or without brakes that are too heavy for the tractor or are towed too fast can cause loss of control. Consider the total weight of the equipment and its load.  
**Note: Observe these recommended maximum road speeds, or local speed limits which may be lower.**
- If towed equipment does not have brakes, do not travel more than 20 mph (32 km/h) and do not tow loads more than 1.5 times the tractor weight.
- If towed equipment does have brakes, do not travel more than 25 mph (40 km/h) and do not tow loads more than 4.5 times the tractor weight.
- Ensure the load does not exceed the recommended weight ratio. Use additional caution when towing loads under adverse surface conditions, when turning, and on inclines.

 **DANGER: Tow loads safely.**





# Torsion Dolly

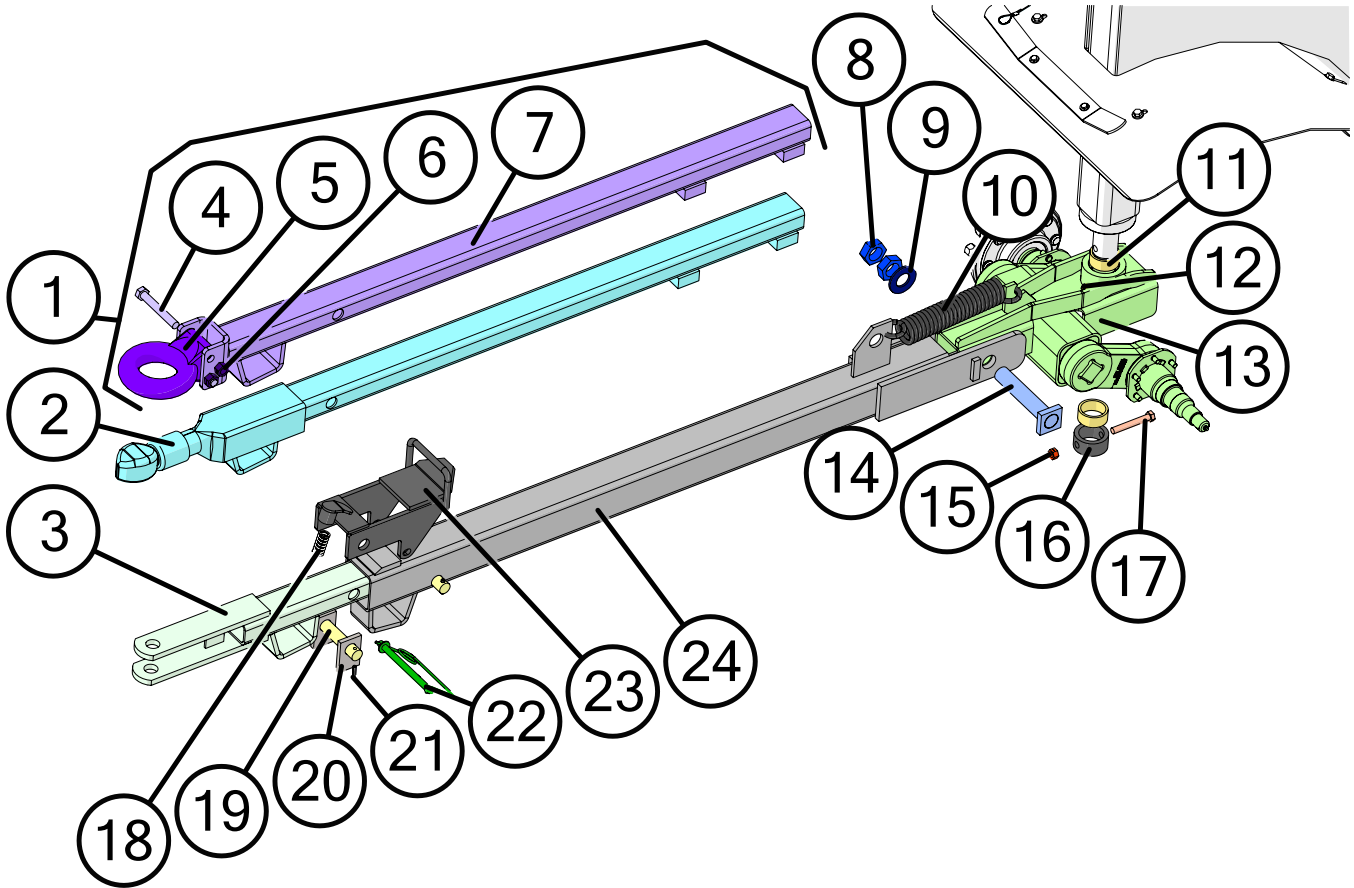

Description	Part No.
1 Trail-Blazer Inner Tongue Pintle Hitch Assembly	JM0075569
2 Torsion Flex Trail-Blazer Inner Tongue Ball Hitch	JM0028697
3 Torsion Flex Trail-Blazer Inner Tongue Clevis	JM0030636
4 .625-11 x 4.5 G8 Zinc Finish hex bolt	JM0075570
5 Lunette Eye (30,000# 3" Forged Eye)	JM0015884
6 5/8"-11 Gr2 Z Centerlock Hex Nut	JM0002146
7 Trail-Blazer Inner Tongue Pintle Hitch Weldment	JM0075567
8 1-1/4"-12 PN Gr2 Hex Jam Nut	JM0001606
9 1-1/4" ID x 2-1/2" OD x 1/8" Z Flat Washer	JM0020322
10 Large Tongue Spring 3/8" x 2" x 12-1/2" (GDP) TS-615H	JM0014200
11 2" ID x 2-3/8" OD x 1" LG Bronze Bushing (EB-2)	JM0027653
12 1/8" NPT Male x 11/16" Straight Grease Fitting	JM0009756
13 Trail Blazer Front Torsion Axle Fixed Spool	JM0060638
14 6-1/2" x 1-1/4" King Pin Weldment (TB-1082)	JM0003036
15 1/2"-13 Gr2 Z Centerlock Hex Nut	JM0001511
16 Trail-Blazer Kingpin Locking Ring	JM0068859
17 1/2"-13 x 3-1/2" Gr5 Z Hex Bolt	JM0009914
18 Compression Spring (1" x 1-3/4") for Door Assembly & Tongue Latch	JM0001688
19 1" x 5-3/4" Flapper Pivot Shaft (LS-610)	JM0027732
20 Spacer Blocks, 2-1/2", 6-15 Ton (SB-212)	JM0003032
21 1/4" x 1-3/8" Roll Pin	JM0009896
22 1/2" x 7" Lynch Pin	JM0030476
23 Flapper Weldment (10T)	JM0030414
24 Trail-Blazer - Outer Hitch Tongue Weldment	JM0061239

# TB-7000 Dolly Hubs

## Torsion Dolly - No Brakes

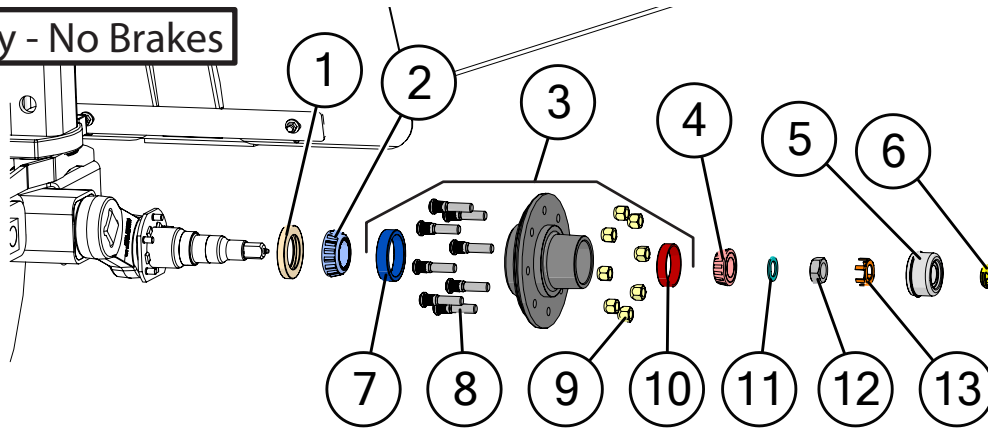

## Torsion Dolly - Brakes

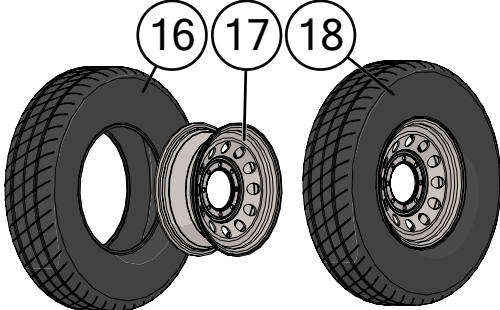
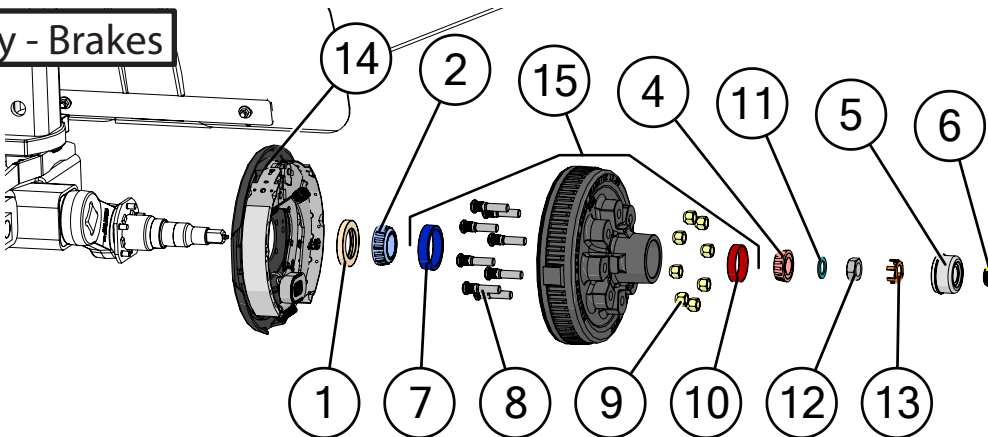

	Description	Part No.
1	2-1/4" ID Grease Seal (010-036-00)	JM0035951
2	Tapered Bearing Cone 25580, 12 Ton	JM0018104
3	7k Idler Hub with Studs, Nuts & Races	JM0058743
4	14125A Roller Bearing	JM0039542
5	Dust Cap for EZ Grease	JM0035957
6	E-Z Lube Rubber Plug	JM0035958
7	Cup, Large Inner, 12 Ton, 25520	JM0018102
8	9/16" x 2-1/2" Stud Silver (WB-41L)	JM0037503
9	9/16"-18 Conical Lugnut (4WS) (ST)	JM0008525
10	Bearing Cup for Superior Gearbox (14-20") (414276)	JM0025077
11	Spindle washer	JM0060784
12	Special 1" Jam Nut for 5.2k, 7k Axles	JM0035955
13	Spring Steel Retaining Clip	JM0051458
14	7K Brake Drum Assembly Left Hand	JM0035973
14	7K Brake Drum Assembly Right Hand	JM0035974
15	7K Hub/Drum w/ Races, Studs, and Lug Nuts	JM0041461
16	235-85-R16 Tire Load Range (F)	JM0016649
17	Wheel Rim, 8 Hole, 16" x 6" (16x6-8)	JM0003233
18	Wheel & Tire (235-85-R16 F Series Tire and 16x6-8 Hole Wheel Rim)	JM0016650

# TB-7000 Rear Axles

## Rear Axle No Brakes

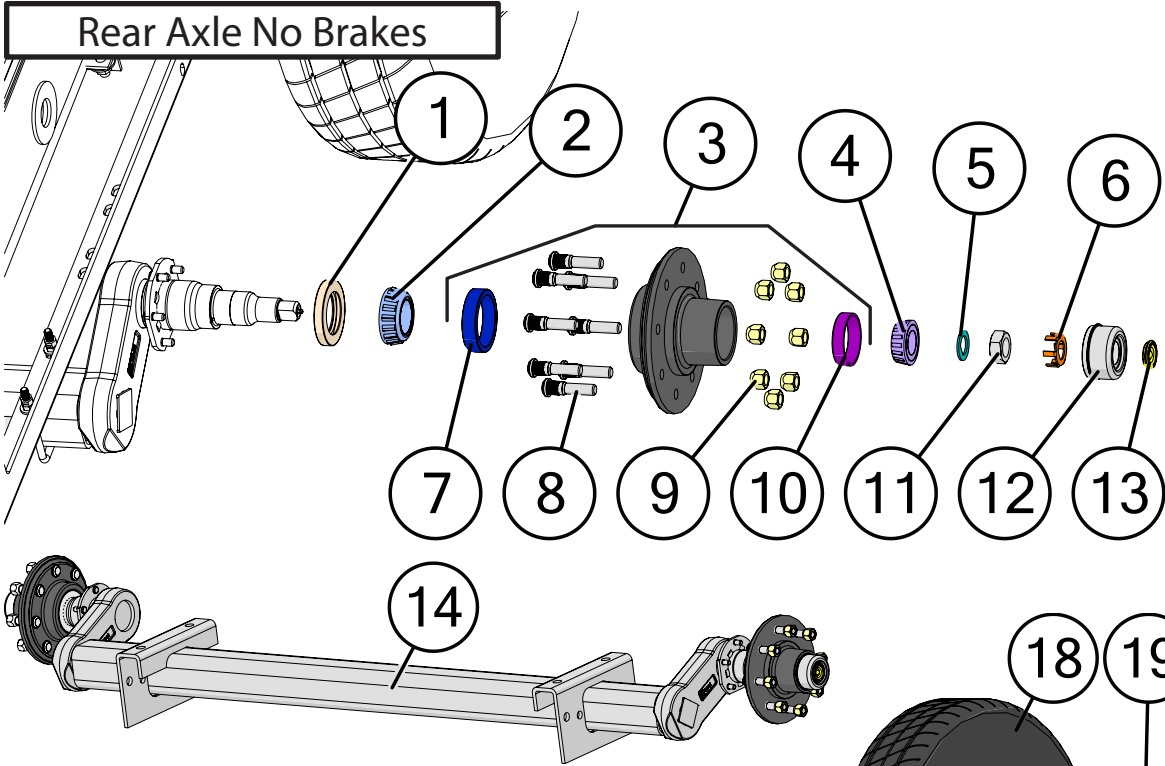

## Rear Axle with Brakes

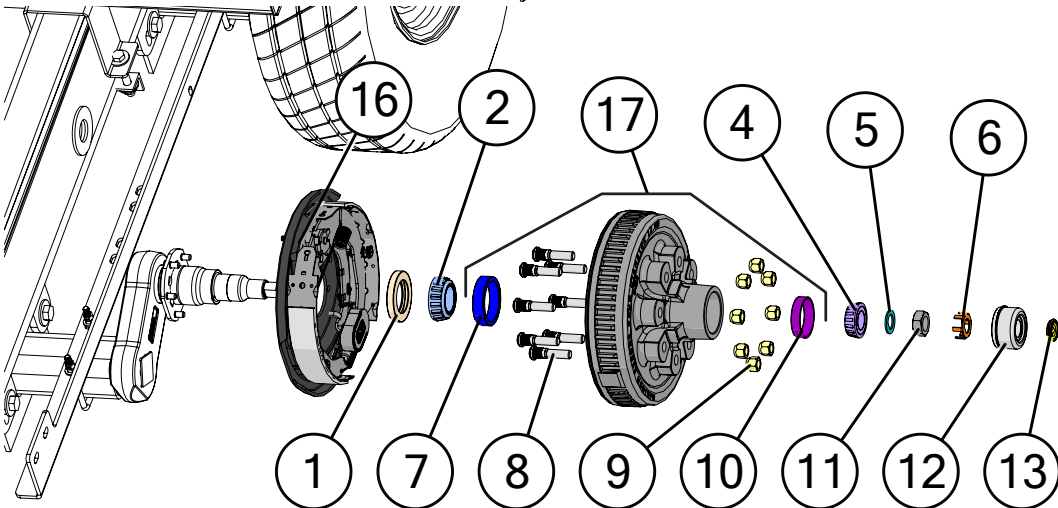
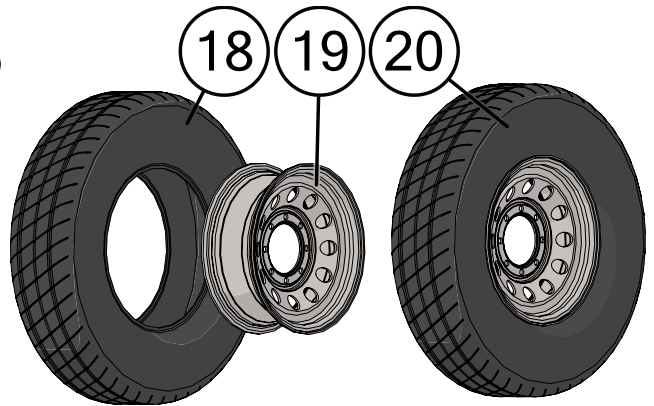
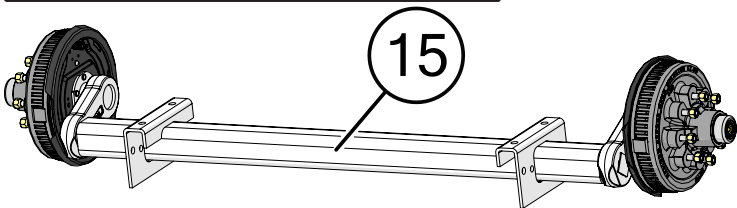

# TB-7000 Rear Axles

	Description	Part No.
1	2-1/4" ID Grease Seal (010-036-00)	JM0035951
2	Tapered Bearing Cone 25580, 12 Ton	JM0018104
3	7k Idler Hub with Studs, Nuts & Races	JM0058743
4	14125A Roller Bearing	JM0039542
5	Spindle washer	JM0060784
6	Spring Steel Retaining Clip	JM0051458
7	Cup, Large Inner, 12 Ton, 25520	JM0018102
8	9/16" x 2-1/2" Stud Silver (WB-41L)	JM0037503
9	9/16"-18 Conical Lugnut (4WS) (ST)	JM0008525
10	Bearing Cup for Superior Gearbox (14-20") (414276)	JM0025077
11	Special 1" Jam Nut for 5.2k, 7k Axles	JM0035955
12	Dust Cap for EZ Grease	JM0035957
13	E-Z Lube Rubber Plug	JM0035958
14	7K Torsion Axle (OB 43.75) Without Brakes	JM0077935
15	7K Torsion Axle (OB 43.75)	JM0074636
16	7K Brake Drum Assembly Left Hand	JM0035973
16	7K Brake Drum Assembly Right Hand	JM0035974
17	7K Hub/Drum w/ Races, Studs, and Lug Nuts	JM0041461
18	235-85-R16 Tire Load Range (F)	JM0016649
19	Wheel Rim, 8 Hole, 16" x 6" (16x6-8)	JM0003233
20	Wheel & Tire (235-85-R16 F Series Tire and 16x6-8 Hole Wheel Rim)	JM0016650



# Header Mounts

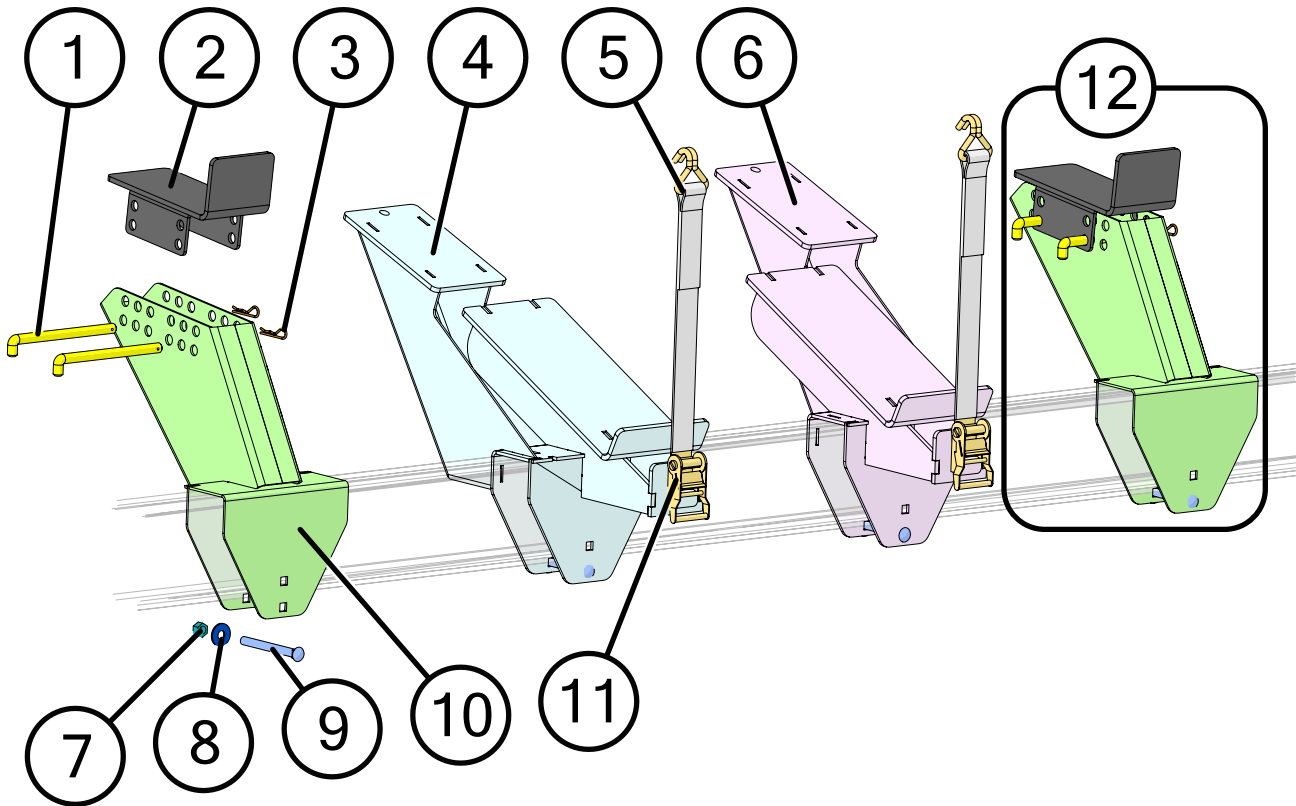

	Description	Part No.
1	3/4" L Pin (10-9/32" Length)	JM0003076
2	Narrow Upper Header Wagon Mount	JM0074195
3	3/16" x 2-1/2" Hair Clip Pin (316HP)	JM0001657
4	Trail Blazer JD HDR Front Center Mount	JM0073723
5	2" Wide x 60" Tie Down Strap with Double J Hook Sewn In (TDS-1)	JM0029979
6	Trail Blazer JD HDR Rear Center Mount Weldment	JM0073746
7	5/8"-11 Gr2 Z Hex Nut	JM0001522
8	5/8" USS Flat Washer	JM0003073
9	5/8"-11 x 6-1/2" Gr5 Z Carriage Bolt	JM0001651
10	Trail Blazer JD HDR Wing Mount Base Assembly	JM0058605
11	2" Tie-Down Ratchet (10,000 lb) (RA-1)	JM0003084
12	Trail Blazer JD HDR Wing Mount Assembly	JM0058606



# Tie-Down

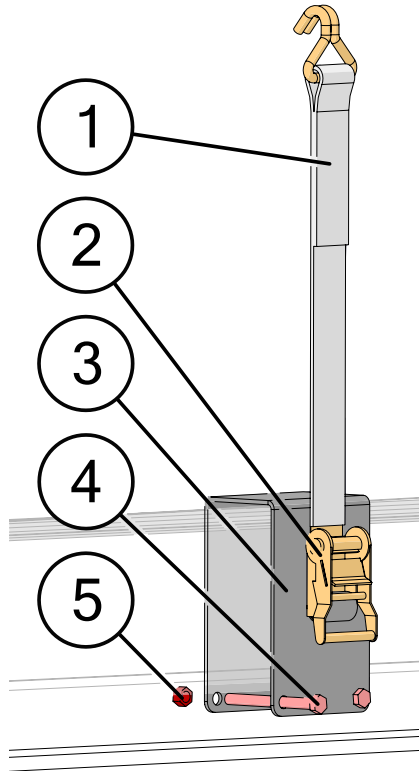

	Description	Part No.
1	2" Wide x 60" Tie Down Strap with Double J Hook Sewn In (TDS-1)	JM0029979
2	2" Tie-Down Ratchet (10,000 lb) (RA-1)	JM0003084
3	Tie-Down Bracket 4" x 8"	JM0058789
4	1/2"-13 x 5-1/2" Gr5 Z Hex Bolt	JM0001498
5	1/2"-13 Gr2 Z Centerlock Hex Nut	JM0001511

# Lifting Arms & Props

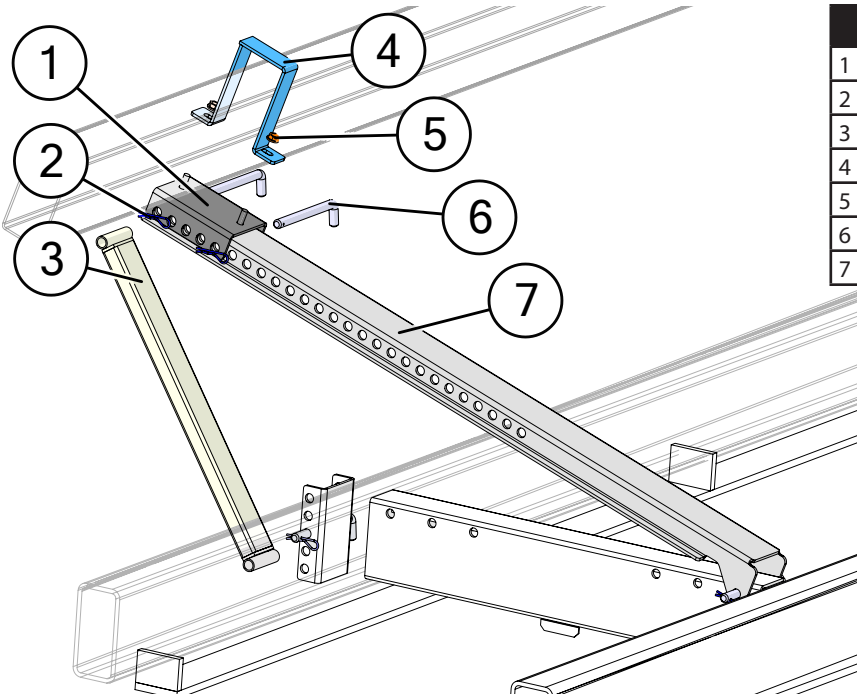

	Description	Part No.
1	Upper Bar Slide Mount (UBSM-3)	JM0015133
2	3/16" x 2-1/2" Hair Clip Pin (316HP)	JM0001657
3	Trail Blazer JD HDR IT Prop Arm Weldment	JM0073789
4	Upper Bar Clamp (4x8) (UBC-3)	JM0003081
5	1/2"-13 Gr5 Z SF Hex Nut	JM0002153
6	3/4" x 8" Z L Pin (Header Wagon, c450)	JM0029738
7	Lifting Arm - 60" Hole Spread (4WS)	JM0003078

# Front Fender

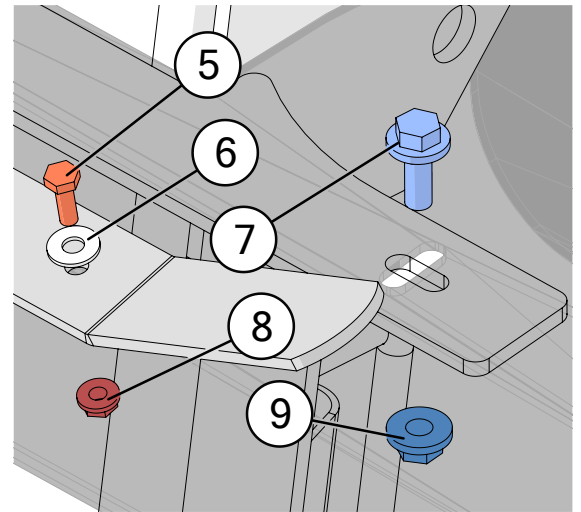
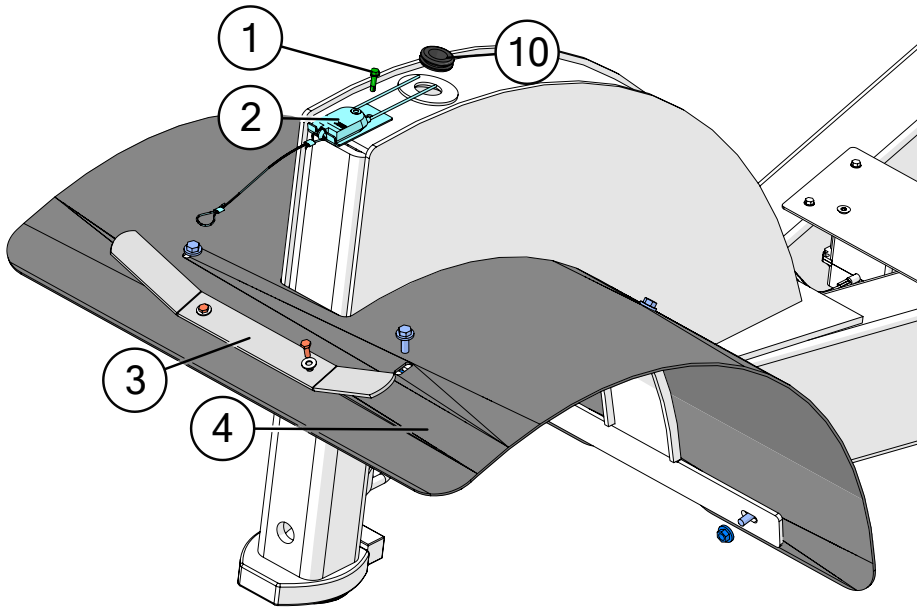

	Description	Part No.
1	1/4" x 1" Self Tapping Screw	JM0001716
2	Breakaway Switch with Cable (BAS-1)	JM0001843
3	Wire Harness Storage Bracket (WHB-1)	JM0001438
4	Trail-Blazer Front Fender	JM0010085
5	1/4"-20 x 3/4" Gr5 Z Hex Bolt	JM0001507
6	1/4" ID, 3/4" OD Z Flat Washer	JM0003090
7	3/8"-16 x 1" Gr5 Z SF Hex Bolt	JM0002092
8	1/4"-20 Gr5 Z SF Hex Nut	JM0001630
9	3/8"-16 Gr5 Z SF Hex Nut	JM0002152
10	1" ID x 3/16" GW x 1-3/8" GD Grommet	JM0016784

# Fender

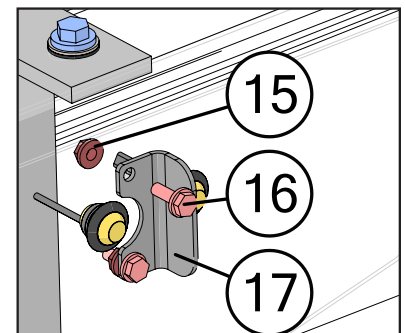
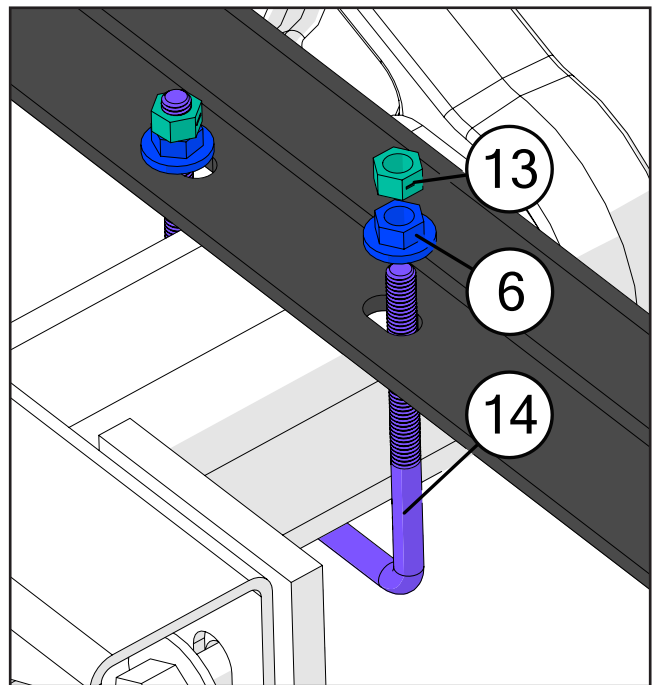
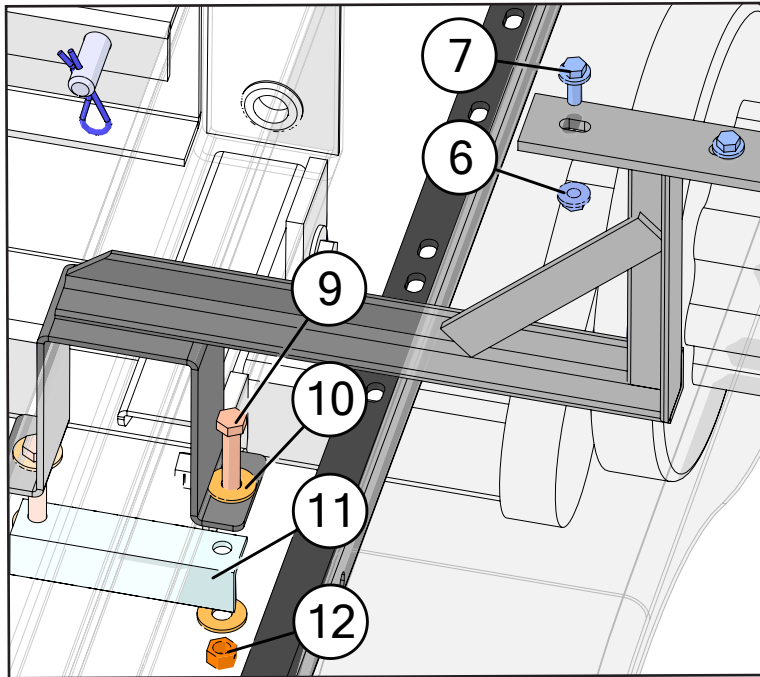
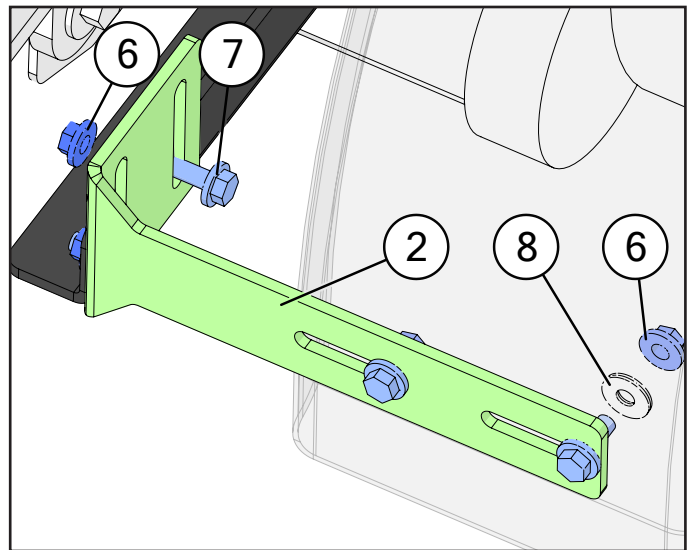
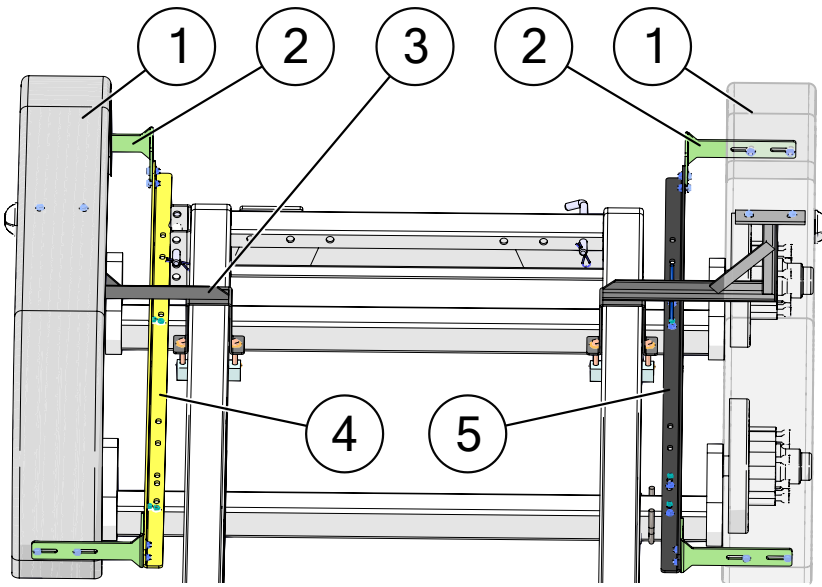

Parts found on highway version

Description	Part No.
1 2-Wheel Fender (72-1/2" Length) (WF-1)	JM0030412
2 High Speed Header Transport Fender Bracket	JM0018610
3 Trail-Blazer Center Fender Support Bracket Weldment (FSA-2-16)	JM0030407
4 72" Fender Bar Right	JM0017948
5 72" Fender Bar Left	JM0017924
6 3/8"-16 Gr5 Z SF Hex Nut	JM0002152
7 3/8"-16 x 1" Gr5 Z SF Hex Bolt	JM0002092
8 3/8" Rubber/Metal Flat Washer	JM0030416
9 1/2"-13 x 3-1/2" Gr5 Z Hex Bolt	JM0009914
10 1/2" ID, 1-3/8" OD Z Flat Washer	JM0003082
11 Header Transport Light Bar Angle Iron Support (AIS-2)	JM0001440
12 1/2"-13 Gr2 Z Centerlock Hex Nut	JM0001511
13 3/8"-16 Gr2 Z Centerlock Hex Nut	JM0001512
14 3/8"-16 x 4" Inside Width x 5" Length Square U-Bolt	JM0080422
15 1/4"-20 Gr5 Z SF Hex Nut	JM0001630
16 1/4"-20 x 3/4" Gr5 Z SF Hex Bolt	JM0001642
17 TrailBlazer Highway Side Marker Light Divider	JM0078465

## Upper Bar

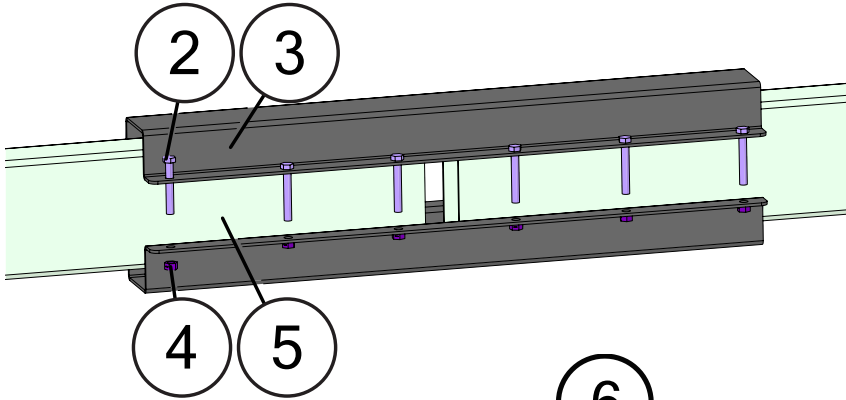
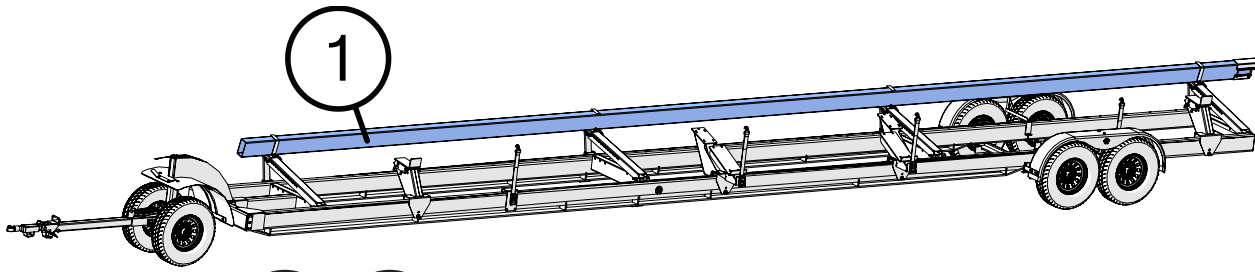

Description	Part No.
1 4" x 8" x 48' Upper Bar	JM0058688
2 1/2"-13 x 3-1/2" Gr5 Z Hex Bolt	JM0009914
3 Splice Clamp for 48' Top Tube	JM0012934
4 1/2"-13 Gr2 Z Centerlock Hex Nut	JM0001511
5 4" x 8" x 26' Top Bar	JM0061230
6 4" x 8" x 52' Upper Bar Assembly	JM0061231

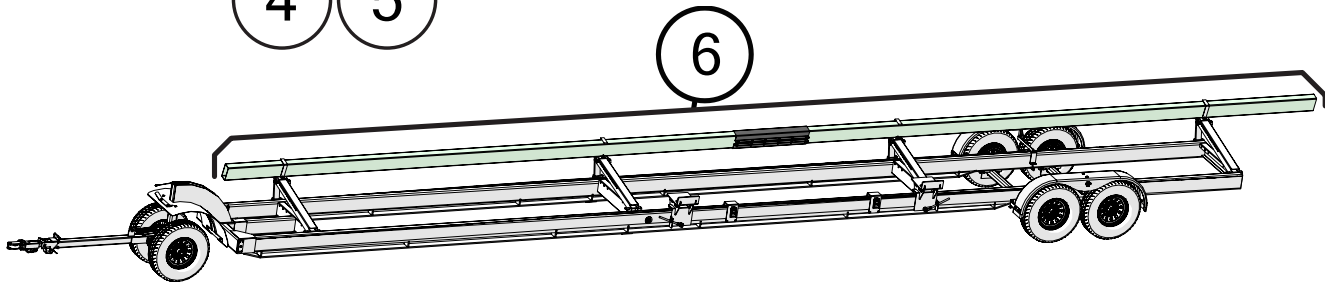

## Wire Conduit

On 52' Upper Bar

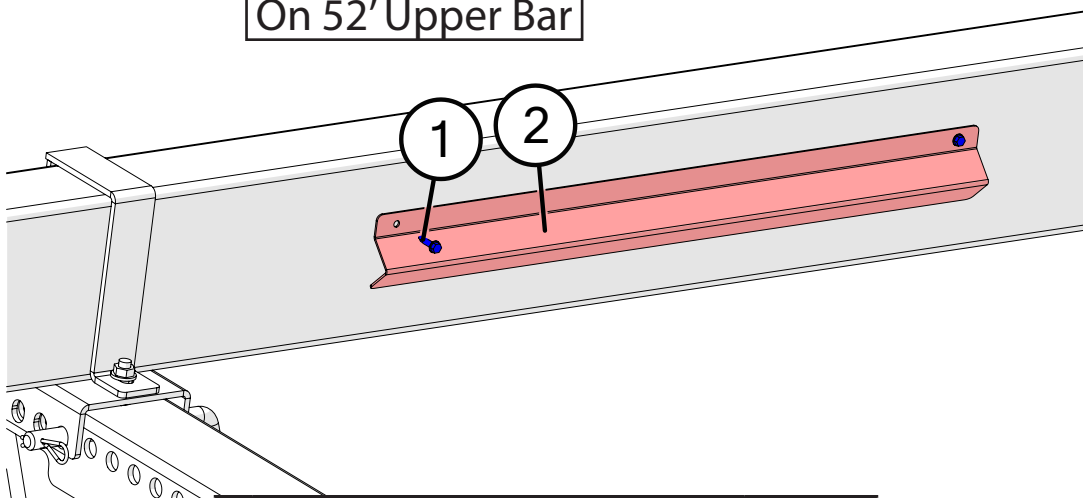

Description	Part No.
1 1/4" x 1" Self Tapping Screw	JM0001716
2 High Speed Header Conduit 30" (32', 38', & 48')	JM0018621

## Highway Upper Bar Extension and Pivoting Lightbar

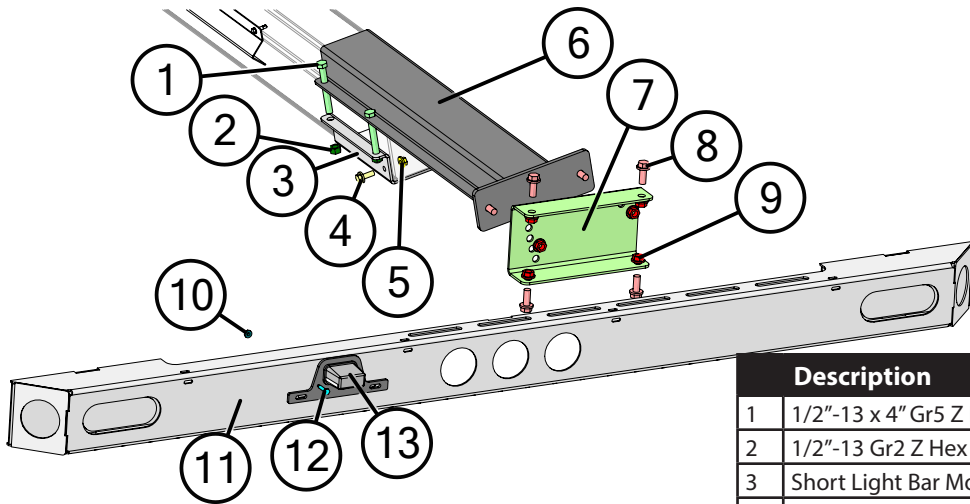

	Description	Part No.
1	1/2"-13 x 4" Gr5 Z Hex Bolt	JM0048014
2	1/2"-13 Gr2 Z Hex Nut	JM0002124
3	Short Light Bar Mount Clamp	JM0061627
4	3/8"-16 x 1" Gr5 Z SF Hex Bolt	JM0002092
5	3/8"-16 Gr5 Z SF Hex Nut	JM0002152
6	Header Transport Light Mount Extension Bracket (2 Hole)	JM0061609
7	Header Transport Light Mount Adapter Bracket	JM0061613
8	1/2"-13 x 1-1/4" Gr5 Z SF Hex Bolt	JM0010002
9	1/2"-13 Gr5 Z SF Hex Nut	JM0002153
10	1/4"-20 Gr5 Z SF Hex Nut	JM0001630
11	Highspeed Header Transport Lightbar Weldment	JM0068907
12	1/4"-20 x 1" Gr5 Z Hex Bolt	JM0002095
13	License Plate Holder and Light	JM0016084

## Ag Upper Bar Extension and Pivoting Lightbar

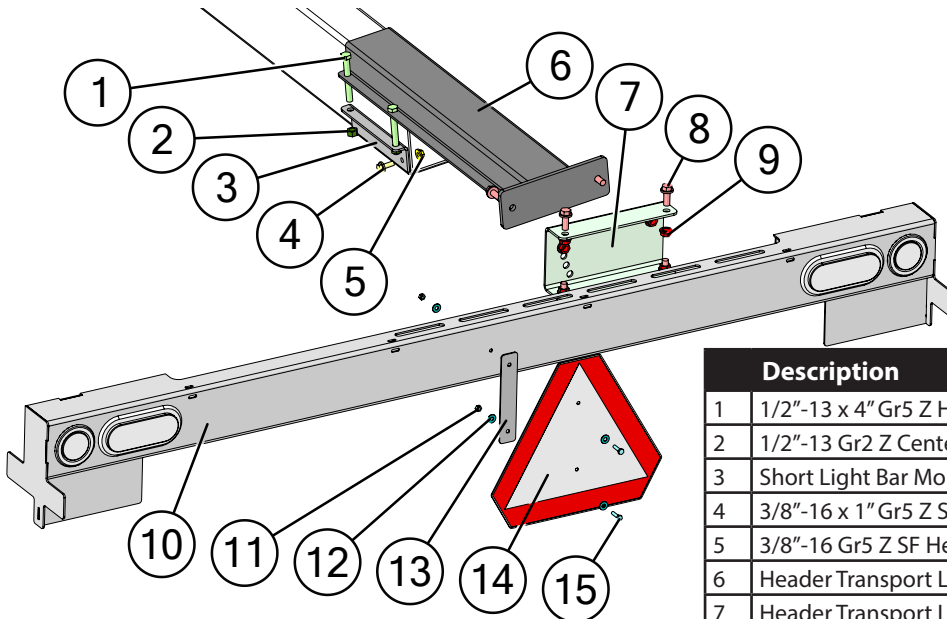

	Description	Part No.
1	1/2"-13 x 4" Gr5 Z Hex Bolt	JM0048014
2	1/2"-13 Gr2 Z Centerlock Hex Nut	JM0001511
3	Short Light Bar Mount Clamp	JM0061627
4	3/8"-16 x 1" Gr5 Z SF Hex Bolt	JM0002092
5	3/8"-16 Gr5 Z SF Hex Nut	JM0002152
6	Header Transport Light Mount Extension Bracket (2 Hole)	JM0061609
7	Header Transport Light Mount Adapter Bracket	JM0061613
8	1/2"-13 x 1-1/4" Gr5 Z SF Hex Bolt	JM0010002
9	1/2"-13 Gr5 Z SF Hex Nut	JM0002153
10	Ag Pivoting Lightbar Weldment (HT)	JM0061619
11	1/4"-20 Gr2 Z Centerlock Hex Nut	JM0001505
12	1/4" ID, 3/4" OD Z Flat Washer	JM0003090
13	Slow Moving Vehicle Sign Bracket	JM0001645
14	Slow Moving Vehicle Sign	JM0001616
15	1/4"-20 x 1" Gr5 Z Hex Bolt	JM0002095

# Lights and Wiring on Pivoting Lightbar- Ag, No Brakes

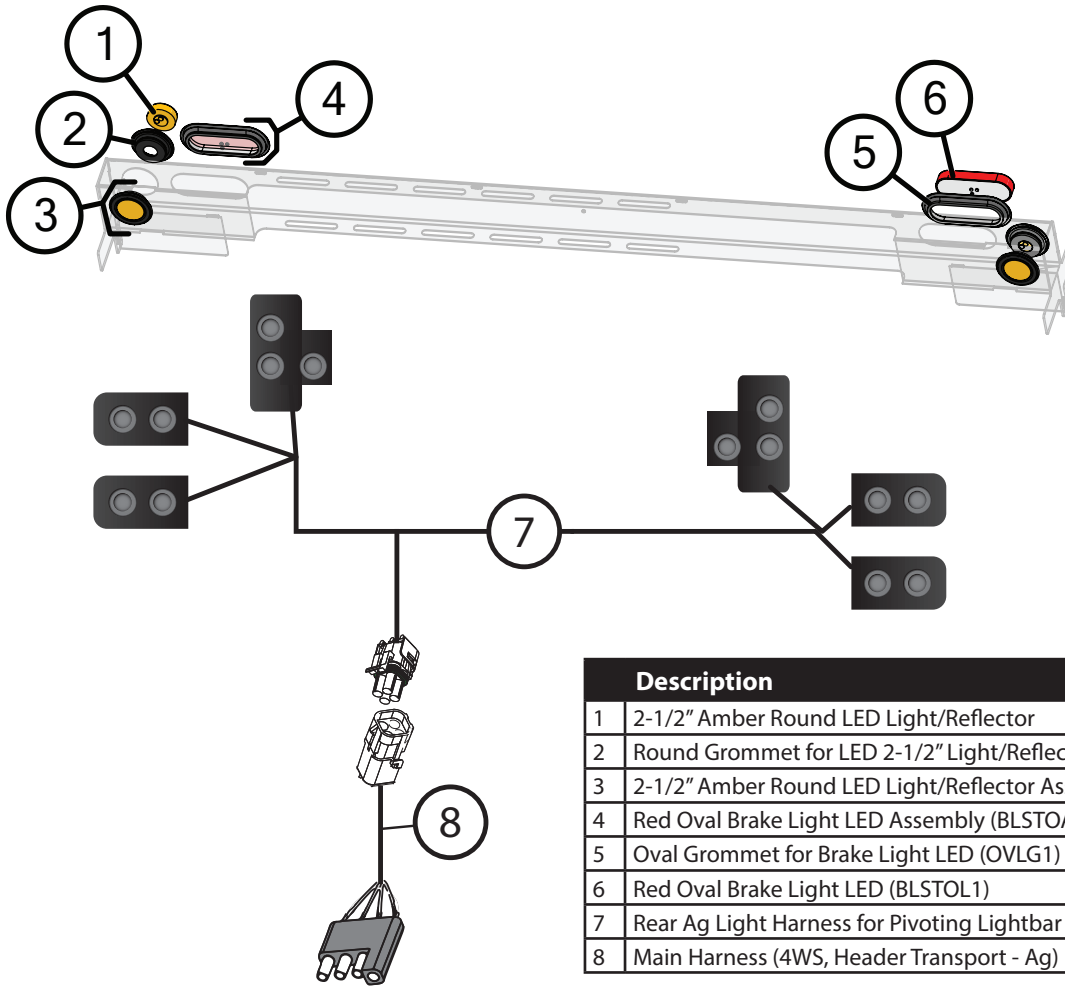

	Description	Part No.
1	2-1/2" Amber Round LED Light/Reflector	JM0001895
2	Round Grommet for LED 2-1/2" Light/Reflector	JM0001902
3	2-1/2" Amber Round LED Light/Reflector Assembly (ARLA1)	JM0001908
4	Red Oval Brake Light LED Assembly (BLSTOA1)	JM0001903
5	Oval Grommet for Brake Light LED (OVLG1)	JM0001897
6	Red Oval Brake Light LED (BLSTOL1)	JM0007114
7	Rear Ag Light Harness for Pivoting Lightbar	JM0081274
8	Main Harness (4WS, Header Transport - Ag)	JM0007436

# Lights and Wiring on Pivoting Lightbar- Ag, with Brakes

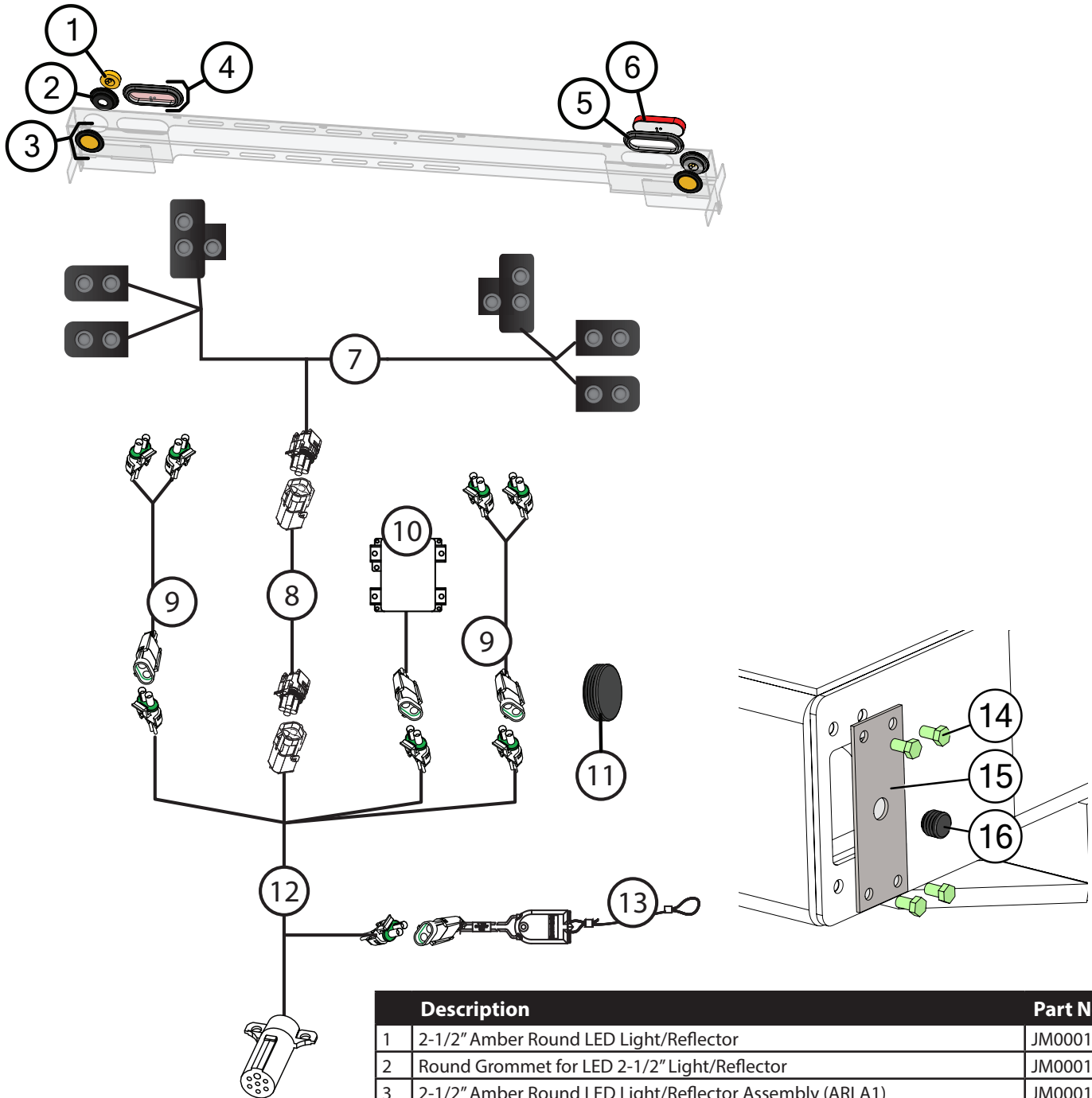

	Description	Part No.
1	2-1/2" Amber Round LED Light/Reflector	JM0001895
2	Round Grommet for LED 2-1/2" Light/Reflector	JM0001902
3	2-1/2" Amber Round LED Light/Reflector Assembly (ARLA1)	JM0001908
4	Red Oval Brake Light LED Assembly (BLSTOA1)	JM0001903
5	Oval Grommet for Brake Light LED (OVLG1)	JM0001897
6	Red Oval Brake Light LED (BLSTOL1)	JM0007114
7	Rear Ag Light Harness for Pivoting Lightbar	JM0081274
8	Trail Blazer Rear Light Harness Extension (Brown, Green, Yellow, and White)	JM0030439
9	Trail-Blazer Main Brake Harness (Blue and White)	JM0030435
10	Break Away Battery Box Assembly (HSBB1)	JM0001833
11	Plastic Plug for 2.25 Hole	JM0073453
12	Main Trail-Blazer Highway Wiring Harness with 7-Way Trailer Connector	JM0007436
13	Breakaway Switch with Cable (BAS-1)	JM0001843
14	3/8"-16 x 5/8" Gr5 Z Hex Bolt	JM0026641
15	Trail-Blazer Main Frame Side Access Plate	JM0061082
16	Plastic Plug for 0.75 Hole	JM0074187



# Lights and Wiring on Pivoting Lightbar- Highway, Brakes

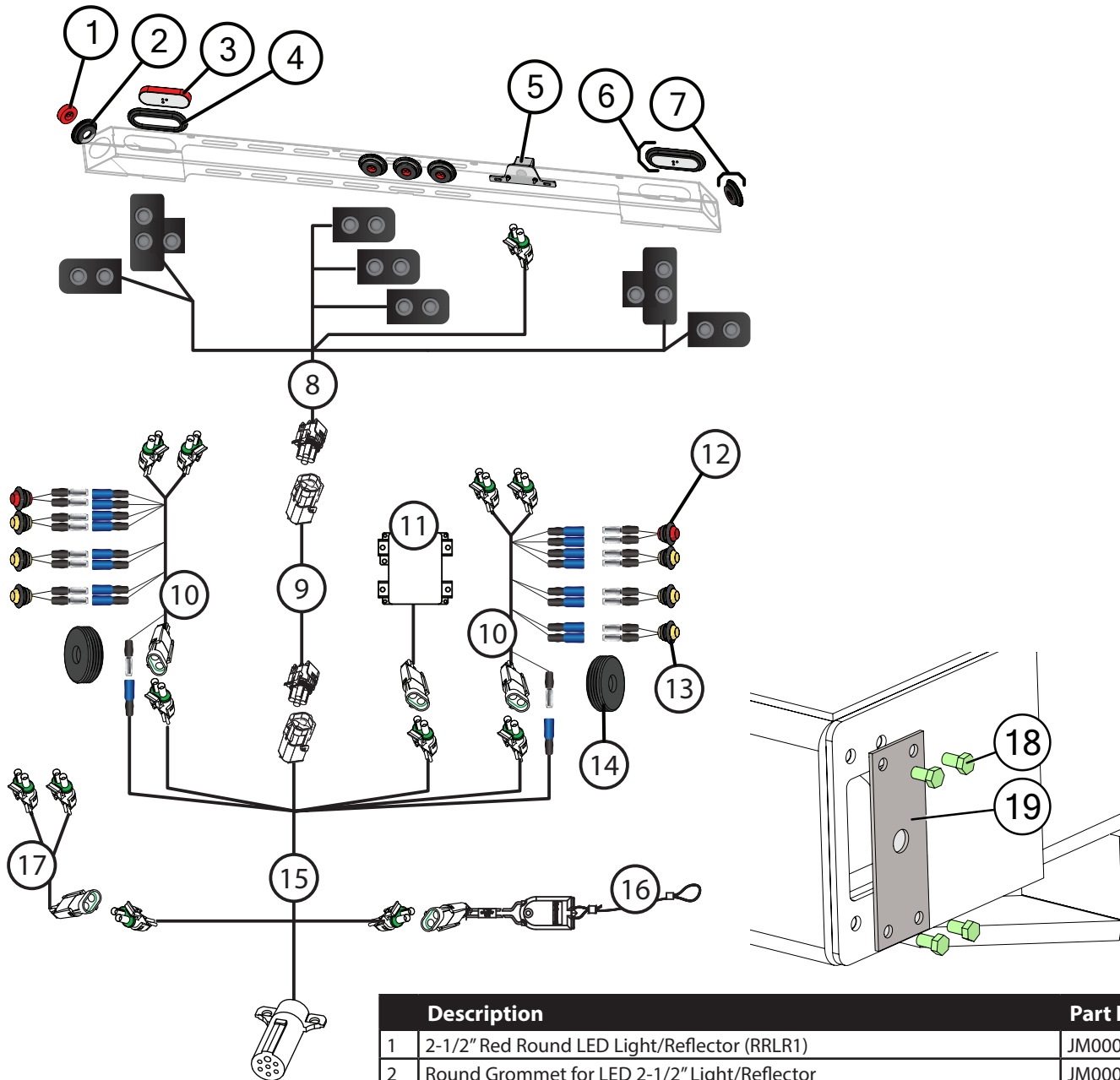

Description	Part No.
1 2-1/2" Red Round LED Light/Reflector (RRLR1)	JM0001901
2 Round Grommet for LED 2-1/2" Light/Reflector	JM0001902
3 Red Oval Brake Light LED (BLSTOL1)	JM0007114
4 Oval Grommet for Brake Light LED (OVLG1)	JM0001897
5 License Plate Holder and Light	JM0016084
6 Red Oval Brake Light LED Assembly (BLSTOA1)	JM0001903
7 2-1/2" Red Round LED Light/Reflector Assembly (RRLA1)	JM0001905
8 Header Transport Light Bar Harness 2023 and Newer	JM0081268
9 Trail Blazer Rear Light Harness Extension (Brown, Green, Yellow, and White)	JM0030439
10 Hwy Main Brake-Marker Harness	JM0081390
11 Break Away Battery Box Assembly (HSBB1)	JM0001833
12 Amber Yellow Mini 3/4" Round 3 LED Side Light Marker Trailer	JM0061221
13 Plastic Plug for 2.25 Hole with 0.75 Center Hole	JM0073454
14 Red Mini 3/4" Round 3 LED Side Light Marker Trailer	JM0061222
15 Main Trail-Blazer Highway Wiring Harness with 7-Way Trailer Connector	JM0030434
16 Breakaway Switch with Cable (BAS-1)	JM0001843
17 HT Front Brake Splitter Option	JM0083349
18 3/8"-16 x 5/8" Gr5 Z Hex Bolt	JM0026641
19 Trail-Blazer Main Frame Side Access Plate	JM0061082