



# Operator's Manual



MODEL

**6018**  
**6026**

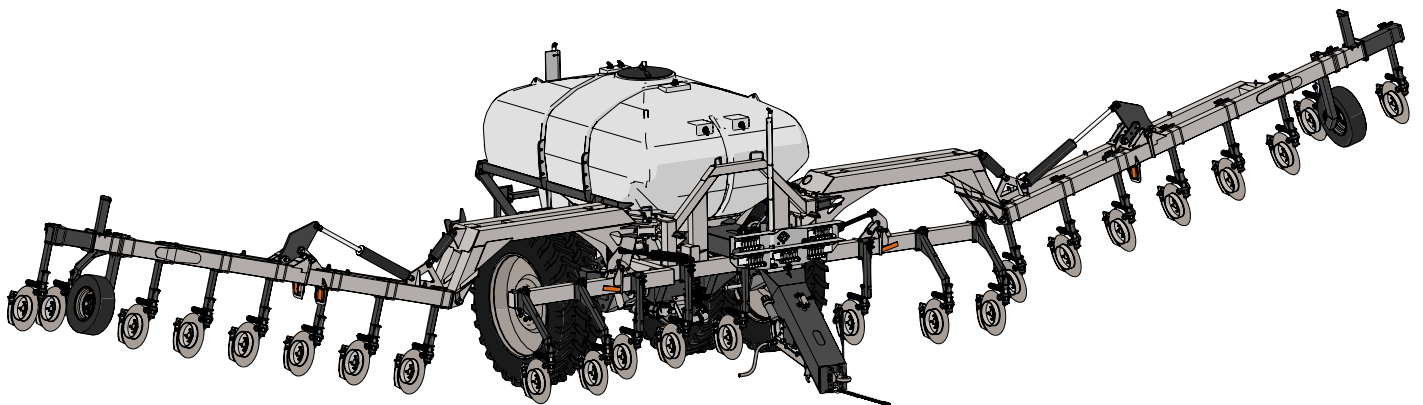
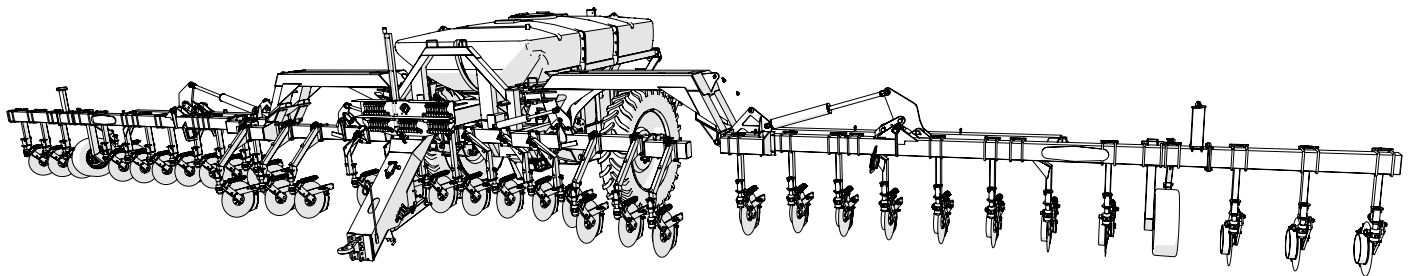

Rev. 6.17.2024

J&M Manufacturing Co, Inc

284 Railroad Street - P.O. Box 547 | Fort Recovery, OH 45846 | Ph: (419) 375-2376 | Fax: (419) 375-2708

[www.jm-inc.com](http://www.jm-inc.com)



# Table Of Contents

To The Dealer .....	4
Serial Number .....	5
General Information .....	5
Safety Rules.....	6
Bolt Torque Chart .....	7
Stud and Wheel Nut Torque Specifications .....	7
6018 Specifications .....	8
6026 Specifications .....	9
Pre-Operation Checklist.....	10
NitroGro Components .....	12
Flow Monitors .....	13
Down Pressure Relief Valve and Gauge.....	13
Strainer.....	13
Hydraulic PWM Pump .....	14
Hand Wash Tank .....	14
Agitation Valve.....	14
Coulter .....	15
Counterbalance Valve .....	15
Connecting the Hydraulic Hoses.....	15
Hitching and Unhitching the Applicator .....	16
Initial Operation .....	17
Folding & Unfolding.....	18
Adjusting the Field Depth .....	20
Operation .....	21
Raven 450 Controller Set Up.....	22
Raven ISOBUS Rate Controller Set Up.....	23
John Deere Greenstar Rate Controller PWM Setup.....	24
Transporting.....	26
Service .....	26
Storage.....	27
Removing Pump Safety Plugs .....	27
Troubleshooting .....	28
Adapter Harnesses for Various Controller Options .....	29
Flow Monitor Set Up .....	30
Changing from 60' to 40' Wing Span .....	31
Injectors - 20" Row Spacing .....	32
Injectors - 22" Row Spacing.....	34
Injectors - 30" Row Spacing.....	36
Knife - 20" Row Spacing .....	38
Knife - 22" Row Spacing .....	40
Knife - 30" Row Spacing .....	42

# To The Dealer

## TO THE DEALER

Read manual instructions and safety rules. Make sure all items on the Dealer's Pre-Delivery and Delivery Check Lists are completed before releasing equipment to the owner.

The dealer must complete the Warranty Registration found on the Dealer Portal website located at dealer.jm-inc.com and return it to J&M Mfg. Co., Inc. at the address indicated on the form. Warranty claims will be denied if the Warranty Registration has not been submitted.

## EXPRESS WARRANTY:

J&M Mfg. Co., Inc. warrants against defects in construction or materials for a period of ONE year. We reserve the right to inspect and decide whether material or construction was faulty or whether abuse or accident voids our guarantee.

Warranty service must be performed by a dealer or service center authorized by J&M Mfg. Co., Inc. to sell and/or service the type of product involved, which will use only new or remanufactured parts or components furnished by J&M Mfg. Co., Inc. Warranty service will be performed without charge to the purchaser for parts or labor based on the Warranty Labor Times schedule. Under no circumstance will allowable labor times extend beyond the maximum hours indicated in the Warranty Labor Times schedule for each warranty procedure. The purchaser will be responsible, however, for any service call and/or transportation of the product to and from the dealer or service center's place of business, for any premium charged for overtime labor requested by the purchaser, and for any service and/or maintenance not directly related to any defect covered under the warranty. Costs associated with equipment rental, product down time, or product disposal are not warrantable and will not be accepted under any circumstance.

Each warranty term begins on the date of product delivery to the purchaser. Under no circumstance will warranty be approved unless (i) the product warranty registration card has been properly completed and submitted to the equipment manufacturer, and (ii) a warranty authorization number has been issued by the equipment manufacturer. This Warranty is effective only if the warranty registration card is returned within 30 days of purchase.

This warranty does not cover a component which fails, malfunctions or is damaged as a result of (i) improper modification or repair, (ii) accident, abuse or improper use, (iii) improper or insufficient maintenance, or (iv) normal wear or tear. This warranty does not cover products that are previously owned and extends solely to the original purchaser of the product. Should the original purchaser sell or otherwise transfer this product to a third party, this warranty does not transfer to the third party purchaser in any way. J&M Mfg. Co., Inc. makes no Warranty, express or implied, with respect to tires or other parts or accessories not manufactured by J&M Mfg. Co., Inc. Warranties for these items, if any, are provided separately by their respective manufacturers.

THIS WARRANTY IS EXPRESSLY IN LIEU OF ALL OTHER WARRANTIES OR CONDITIONS, EXPRESS, IMPLIED OR STATUTORY, INCLUDING ANY IMPLIED WARRANTY OF MERCHANTABILITY OR FITNESS FOR PARTICULAR PURPOSE.

In no event shall J&M Mfg. Co., Inc. be liable for special, direct, incidental or consequential damages of any kind. The exclusive remedy under this Warranty shall be repair or replacement of the defective component at J&M Mfg. Co., Inc.'s option. This is the entire agreement between J&M Mfg. Co., Inc. and the Owner about warranty and no J&M Mfg. Co., Inc. employee or dealer is authorized to make any additional warranty on behalf of J&M Mfg. Co., Inc.

The manufacturer reserves the right to make product design and material changes at any time without notice. They shall not incur any obligation or liability to incorporate such changes and improvements in products previously sold to any customer, nor shall they be obligated or liable for the replacement of previously sold products with products or parts incorporating such changes.

## SERVICE:

The equipment you have purchased has been carefully manufactured to provide dependable and satisfactory use. Like all mechanical products, it will require cleaning and maintenance. Lubricate the unit as specified. Observe all safety information in this manual and safety signs on the equipment.

For service, your authorized J&M dealer has trained mechanics, genuine J&M service parts, and the necessary tools and equipment to handle all your needs.

Use only genuine J&M service parts. Substitute parts may void warranty and may not meet standards required for safety and satisfactory operation. Record the model number and serial number of your equipment in the spaces provided:

**Model No:** 6018 or 6026 NitroGro Applicator **Serial No:** \_\_\_\_\_ **Date of Purchase:** \_\_\_\_\_

**Purchased From:** \_\_\_\_\_

Provide this information to your dealer to obtain correct repair parts.





# Serial Number



Serial Number \_\_\_\_\_  
Model Number \_\_\_\_\_ 6018 or 6026 \_\_\_\_\_

Standard practice when ordering parts or obtaining information from your dealer requires the serial number and model number. Have numbers available before making contact.

# General Information

## TO THE OWNER:

The purpose of this manual is to assist you in operating and maintaining your applicator in a safe manner. Read it carefully. It furnishes information and instructions that will help you achieve years of dependable performance and help maintain safe operating conditions. If this machine is used by an employee or is loaned or rented, make certain that the operator(s), prior to operating:

1. Is instructed in safe and proper use.
2. Reviews and understands the manual(s) pertaining to this machine.

Throughout this manual, the term **IMPORTANT** is used to indicate that failure to observe can cause damage to equipment. The terms **CAUTION**, **WARNING** and **DANGER** are used in conjunction with the Safety-Alert Symbol, (a triangle with an exclamation mark), to indicate the degree of hazard for items of personal safety. When you see this symbol, carefully read the message that follows and be alert to the possibility of personal injury or death.



This Safety-Alert symbol indicates a hazard and means **ATTENTION! BECOME ALERT! YOUR SAFETY IS INVOLVED!**



### **DANGER**

Indicates an imminently hazardous situation that, if not avoided, will result in death or serious injury.



### **WARNING**

Indicates a potentially hazardous situation that, if not avoided, could result in death or serious injury, and includes hazards that are exposed when guards are removed.



### **CAUTION**

Indicates a potentially hazardous situation that, if not avoided, may result in minor or moderate injury.

### **IMPORTANT**

Indicates that failure to observe can cause damage to equipment.

### **NOTE**

Indicates helpful information.

# Safety Rules

## **ATTENTION! BECOME ALERT! YOUR SAFETY IS INVOLVED!**

Safety is a primary concern in the design and manufacture of our products. Unfortunately, our efforts to provide safe equipment can be erased by an operator's single careless act. In addition, hazard control and accident prevention are dependent upon the awareness, concern, judgment, and proper training of personnel involved in the operation, transport, maintenance and storage of equipment.

Make certain that the operator(s), prior to operating is instructed in safe and proper use and reviews and understands the manual(s) pertaining to this machine. Also make certain that the operator(s) reviews and understands the operator's manual of the tow vehicle prior to hooking up or operating the NitroGro Applicator.

Read this manual before you operate this machine. If you do not understand any part of this manual, or need more information, contact the manufacturer or your authorized dealer.

Note: The right and the left hand sides of the implement are determined by facing the same direction that the applicator will travel when moving forward.

## **SAFETY**

Understand that your safety and the safety of other persons is measured by how you service, and operate this machine. Know the positions and functions of all controls before you try to operate them. Make sure to check all controls in a safe area before starting your work.

The safety information given in this manual does not replace safety codes, federal, state or local laws. Make certain your machine has the proper equipment as designated by local laws and regulations.

A frequent cause of personal injury or death is from persons falling off equipment and being run over. Do not permit persons to ride on this machine.

Travel speeds should be such that complete control and machine stability is maintained at all times. Where possible, avoid operating near ditches, embankments and holes. Reduce speed when turning, crossing slopes and rough, slick or muddy surfaces.

Collision of high speed road traffic and slow moving machines can cause personal injury or death. On roads, use flasher lights according to local laws. Keep slow-moving-vehicle emblem visible. Pull over to let faster traffic pass.

Keep all safety shields in place.

Keep hands, feet, hair and clothing away from moving parts while unit is in operation.

Ensure that everyone is clear of equipment before applying power or moving the machine.

Fasten the implement securely to the tractor by using the proper hitch pin, clip and safety chains.

Do NOT exceed speeds in excess of 20 MPH. Also be sure slow moving vehicle emblem is attached to rear of transport.

Do not transport applicator with contents in the tank.

Before unhooking the implement from the towing unit, be sure to properly block the wheels to prevent the implement from moving. Be sure the jack assembly is positioned in the park position and the weight has been transferred to the jack assembly before unhooking the implement. **Do not unhook with contents in tank or toolbar in operating position.**

Avoid high pressure fluids. Escaping fluid under pressure can penetrate the skin causing serious injury. Always relieve pressure before disconnecting hydraulic lines. Wear proper hand and eye protection when searching for leaks. Use wood or cardboard instead of hands. Keep all components in good repair.

# Bolt Torque Chart

Always tighten hardware to these values unless a different torque or tightening procedure is listed for specific application. Fasteners must always be replaced with the same grade as specified in the manual parts list. Always use the proper tool for tightening hardware. Make sure fastener threads are clean and you start thread engagement properly. **Use these values when tightening all bolts and nuts with the exception of wheel nuts.**

## SAE Fasteners

Coarse Thread Series				
Diameter and Pitch (Inches)	Grade 5		Grade 8	
	Dry	Oiled	Dry	Oiled
1/4"-20	8 ft-lbs	6 ft-lbs	12 ft-lbs	9 ft-lbs
5/16"-18	17	13	25	18
3/8"-16	31	23	44	33
7/16"-14	49	37	70	52
1/2"-13	75	57	106	80
9/16"-12	109	82	154	115
5/8"-11	150	113	212	159
3/4"-10	267	200	376	282
7/8"-9	429	322	606	455
1"-8	644	483	909	681
Fine Thread Series				
Diameter and Pitch (Inches)	Dry	Oiled	Dry	Oiled
1/4"-28	10 ft-lbs	7 ft-lbs	14 ft-lbs	10 ft-lbs
5/16"-24	19	15	27	20
3/8"-24	35	26	49	37
7/16"-20	55	41	78	58
1/2"-20	85	64	120	90
9/16"-18	121	91	171	128
5/8"-18	170	127	240	180
3/4"-16	297	223	420	315
7/8"-14	474	355	669	502

## Stud and Wheel Nut Torque Specifications

Always tighten hardware to these values unless a different torque or tightening procedure is listed for specific application. Fasteners must always be replaced with the same grade as specified in the manual parts list. Always use the proper tool for tightening hardware. Make sure fastener threads are clean and you start thread engagement properly. **Use these values when tightening all studs and wheel nuts.**

Stud	Tightening Torque
1/2"-20	80 ft-lbs
9/16"-18	170 ft-lbs
5/8"-18	350 ft-lbs
3/4"-16	400 ft-lbs
20mm	475 ft-lbs
22mm	640 ft-lbs

**TIGHTENING WHEEL NUTS:** During initial operation of the NitroGro applicator, **tighten standard 3/4" wheel studs and nuts to torque 400 ft-lbs and tighten 1/2"-20 gauge wheel studs and nuts to torque 80 ft-lbs.** Check for proper torque after every 10 hours of use. Failure to do so may damage wheel nut seats. Once seats are damaged, it will become impossible to keep nuts tight.

# 6018 Specifications

SPECIFICATIONS 6000 Series Applicators		<b>6018</b>
Tank Size	1,850 Gallon	
Base Width	60'	
Ground Clearance	40"	
Row Spacing*	20", 22", 30"	
Number of Coulters	23, 25, 35, 37	
Coulter Style	Grove Engineered Products (GEP) or J&M Para-Linkage	
Fertilizer Delivery	Knife or Injection	
Wing Flex	Standard 15° Flex Up - 10° Flex Down	
Wing Kick	Standard 15° Kick Up	
Coulter Frame Tubing	5" x 7" Double Toolbar	
Hydraulic Down Pressure	Standard	
Standard PWM Hydraulic Driven Pump	Ace 155 or 750 Pump	
Transport Width	11'-9"	
Transport Height	11'-10"	
Transport Length	25'-0"	
Pin To Axle	14'-0"	
Flow Monitors	Standard - Wilger	
Depth Control Spools	Optional	
Quick Fill	3" Fill Standard	
Wash Tank	Standard 9 Gallon Wash Tank	
Empty Weight	16,000 lbs.	

\* Other Row Spacing Available Upon Request

With toolbar folded:

	Total Weight	Weight on Axle	Tongue Weight
Tank Empty	16,000 lbs	15,350 lbs	650 lbs
Tank Full	37,000 lbs	34,800 lbs	2,200 lbs

With toolbar unfolded and raised (knives not in ground):

	Total Weight	Weight on Axle	Tongue Weight
Tank Empty	16,000 lbs	11,229 lbs	4,771 lbs
Tank Full	37,000 lbs	31,245 lbs	5,755 lbs

With toolbar unfolded and down (knives in ground):

	Total Weight	Weight on Axle*	Tongue Weight*
Tank Empty	16,000 lbs	6,215 lbs	1,034 lbs
Tank Full	37,000 lbs	26,231 lbs	2,018 lbs

\*These values are estimates assuming moderate soil hardness and 25 coulters.

## Compaction (PSI)

VF380/90R46 Tire (15" Width) Standard Single Wheels	57 psi
VF520/85R42 Tire (21" Width) Optional Single Wheels	31 psi
VF320/105R46 Tire (12.5" Width) Optional Single Wheels	71 psi
VF380/90R46 Tire (15" Width) Optional Dual Wheels	17 psi
VF520/85R42 Tire (21" Width) Optional Dual Wheels	11 psi
VF320/105R46 Tire (12.5" Width) Optional Dual Wheels	20 psi
Camsso Track System (18" Width)	11.5 psi

Note: These values are estimates assuming a full tank of 32%, 25 coulters in the ground with moderate soil hardness on 30" rows.

# 6026 Specifications

SPECIFICATIONS 6000 Series Applicators		<b>6026</b>
Tank Size	2,600 Gallon	
Base Width	60'	
Ground Clearance	40"	
Row Spacing*	20", 22", 30"	
Number of Coulters	23, 25, 35, 37	
Coulter Style	Grove Engineered Products (GEP) or J&M Para-Linkage	
Fertilizer Delivery	Knife or Injection	
Wing Flex	Standard 15° Flex Up - 10° Flex Down	
Wing Kick	Standard 15° Kick Up	
Coulter Frame Tubing	5" x 7" Double Toolbar	
Hydraulic Down Pressure	Standard	
Standard PWM Hydraulic Driven Pump	Ace 155 or 750 Pump	
Transport Width	11'-9"	
Transport Height	12'-6"	
Transport Length	25'-0"	
Pin To Axle	14'-0"	
Flow Monitors	Standard - Wilger	
Depth Control Spools	Optional	
Quick Fill	3" Fill Standard	
Wash Tank	Standard 9 Gallon Wash Tank	
Empty Weight	18,000 lbs.	

\* Other Row Spacing Available Upon Request

With toolbar folded:

	Total Weight	Weight on Axle	Tongue Weight
Tank Empty	18,000 lbs	17,300 lbs	700 lbs
Tank Full	47,000 lbs	44,200 lbs	2,800 lbs

With toolbar unfolded and raised (knives not in ground):

	Total Weight	Weight on Axle	Tongue Weight
Tank Empty	18,000 lbs	13,436 lbs	4,563 lbs
Tank Full	47,000 lbs	40,773 lbs	6,226 lbs

With toolbar unfolded and down (knives in ground):

	Total Weight	Weight on Axle*	Tongue Weight*
Tank Empty	18,000 lbs	8,422 lbs	827 lbs
Tank Full	47,000 lbs	35,759 lbs	2,490 lbs

\*These values are estimates assuming moderate soil hardness and 25 coulters.

## Compaction (PSI)

VF380/90R46 Tire (15" Width) Standard Dual Wheels	25 psi
VF520/85R42 Tire (21" Width) Optional Dual Wheels	16 psi
VF320/105R46 Tire (12.5" Width) Optional Dual Wheels	29 psi
Camso Track System (18" Width)	14.8 psi

Note: These values are estimates assuming a full tank of 32%, 25 coulters in the ground with moderate soil hardness on 30" rows.

# Pre-Operation Checklist

**IMPORTANT - Before putting the applicator into operation, check the machine for damaged or worn parts and replace as necessary.**

## ***Wheel Nuts Tightened***

During initial operation, tighten standard 3/4" wheel studs and nuts to torque 400 ft-lbs and tighten 1/2"-20 studs and nuts on gauge wheels to torque 80 ft-lbs. Re-check wheel nut torque settings during initial break in period (10, 20, 50 acres), then every 10 hours of use for the first 40 hours. Continue checking wheel nut settings until nuts do not loosen. If wheel nuts loosen, they may damage wheel nut seats. Once seats are damaged, it will become impossible to keep nuts tight.

***Failure to keep the wheel nuts tight could cause considerable damage to the applicator and surrounding. It is the dealer's responsibility to torque the wheel nuts to specification before delivery. Damage caused by failure to keep wheel nuts tight is not warrantied.***

## ***Wheels and Tires***

Check the tire pressure in the transport and gauge wheel tires and make sure the tire pressure is equal for each tire. Refer to "Operation" on page 21 for tire pressure recommendations. Tighten standard 3/4" wheel studs and nuts on transport tires to torque 400 ft-lbs and tighten 1/2"-20 studs and nuts on gauge wheels to torque 80 ft-lbs. Check the wheel lug nuts before initial operation and after the unit has been operated for several hours to ensure the lug nuts remain tight.

## ***Hardware***

Ensure all hardware is properly fastened according to the "Bolt Torque Chart" on page 7. Recheck all hardware for tightness after the unit has been operated for several hours. Check that all pins and retaining rings are in good condition. Replace any pins or retaining rings that are worn, damaged or missing.

## ***Grease Points***

Check all bearings and grease fittings for proper lubrication, outlined in "Service" on page 26.

## ***Hydraulic Hoses***

Ensure hydraulic hoses are not kinked, twisted, or rubbing against sharp edges. Secure hoses to the applicator with nylon tie straps. Unfold and fold the applicator according to the fold instructions decal on the tongue of the applicator or in the operator's manual. Check for leaks on hydraulic cylinders, fittings, and hose ends (Use cardboard or wood to safely check for leaks) and tighten where necessary.

## ***Clean Tank***

Check tank for debris (like plastic shavings from assembly) and clean if necessary. Use a vacuum to remove tank debris.

## ***Indicator Balls***

Remove all indicator balls from flow monitors and install the correct indicator ball in each flow monitor for the customer's desired gallons per acre and speed. Refer to pages 32-43 to determine which indicator ball to select.

## ***Water Test***

Fill tank with 100 gallons of water and water test before use. Most rate controllers have a "self-test" mode that for this purpose. Tighten any leaking hose or fitting connections. **Do not run the fertilizer pump dry. This could cause permanent failure to the fertilizer pump and is not warrantied.**

## ***Winterization***

If applicator has ever had fluid in the tank, winterize the applicator before the temperature drops below freezing. See the operator's manual for winterizing instructions. **Failing to winterize applicator can cause severe damage to fertilizer distribution components and is not warrantied.**

## ***Defects & Scratches***

Examine paint and poly tank for scratches, cracks, gouges, and defects.



# Pre-Operation Checklist

## **Filling the Tank**

**⚠ Warning: Ensure the applicator is pinned to the tractor before filling tank. The applicator must be pinned to a tractor when any fluid is present in the tank.**

Make sure the area is clear of bystanders when filling the tank. Always wear protective clothing, gloves, and masks when handling fertilizer/chemicals. Follow the fertilizer/chemical manufacturer's instructions when filling the tank. Keep the tank lid on at all times to keep out debris.

## **Fertilizer Pump**

Raise the toolbar with wings unfolded and turn on the fertilizer pump. Check if liquid is coming out of each knife/injector. Clean or replace knives/injectors if necessary.

## **Unfolding the Wings**

It is recommended to unfold the side wings in the field. Keep all bystanders away while unfolding the wings. See "Folding & Unfolding" on page 18.

## **Safety Decals & Lights**

Check that safety decals, reflective decals, and lights are properly located. Refer to "Decals" page of the Parts Manual for proper placement. Ensure all lights function properly.

## **SMV**

Position the SMV emblem with one point of the triangle upward and as near to the rear and centered or as near to the left of center of the unit as practicable. Secure the SMV emblem two to ten feet above the ground measured from the lower edge of the emblem. Before transporting, ensure that SMV emblem is clean and visible.



# NitroGro Components

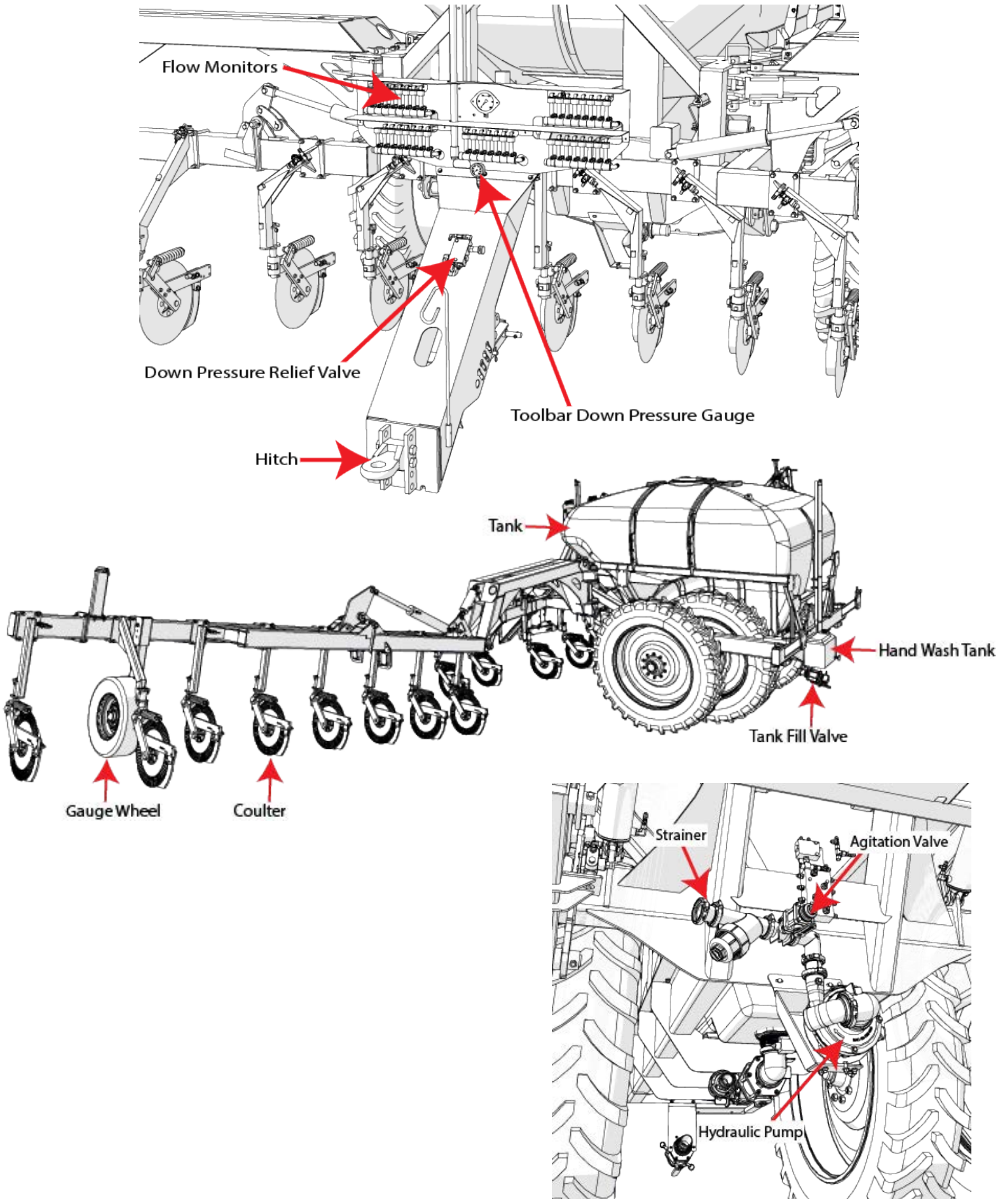



# Flow Monitors

Flow monitors allow the operator to check for blockages at each coulter with a floating ball inside the transparent inspection tube. Each coulter is connected with a separate supply hose.

**Note:** The height in each flow monitor is not necessarily an accurate portrayal of the flow in each row, merely an indication of flow.



# Down Pressure Relief Valve and Gauge

The down pressure relief valve provides adjustable hydraulic pressure to force the coulters on the wings into the ground and keep the coulters at the correct depth. While allowing the wing to flex up and down as needed to follow the contour of the ground.

- Turn clockwise to increase down pressure.
- Turn counter clockwise to decrease down pressure.

**⚠ IMPORTANT - DO NOT TO EXCEED 1,350 psi** of pressure on the down pressure gauge. It is recommended to use the least amount of pressure necessary to keep the coulters in the ground. Excessive pressure can cause premature wear on wing pivots and gauge wheels. Exceeding 1,350 psi will void the manufacturers warranty.



# Strainer

The NitroGro applicator is equipped with a strainer designed to remove dirt and debris from the fertilizer to prevent downstream clogs. **The strainer should be cleaned daily during regular operation.**



## Hydraulic PWM Pump

The standard pump for your NitroGro applicator is the Ace FMC-155-HYD-206 with PWM control. The maximum hydraulic fluid input for this pump is 7 gallons per minute. The optional, larger pump available for your applicator is the Ace FMC-750-HYD pump with PWM control. The maximum hydraulic fluid input pump for this pump is 18 gallons per minute.

**IMPORTANT - Do not exceed 7 gallons per minute hydraulic fluid input when using the Ace FMC-155-HYD-206 pump or 18 gallons per minute when using the Ace FMC-750-HYD pump.** Refer to the pump's operating manual to regulate the hydraulic flow to the pump.

**⚠ WARNING- Failure to regulate oil flow will cause motor failure and will void the manufacturer's warranty.**

The hydraulic pump is located below the tank and near the tank outlet to prevent cavitation and provide faster pump priming.

Attach the pump hydraulic hoses to the tractor so the pump operates in the lower/retract position. The pump can then be turned off in the forward "float" position. Turning the pump off in "float" instead of "neutral" allows the hydraulic system pressure to equalize and prevents the occurrence of damaging pressure spikes. Failure to do this will void the manufacturer's warranty.

Connect the return line to a low pressure return port, if available. The low pressure return port routes oil directly to the reservoir, minimizing return line pressure. Low return line pressure extends the motor seal life and increases operating efficiency. Pump failures due to high pressure return lines will void the manufacturer's warranty.

Turn the hydraulic flow of the tractor all the way down before you put the hydraulic fertilizer pump into use. The applicator pump only requires 7 GPM of hydraulic flow to make 120 GPM of fertilizer flow. If you don't turn down the tractor hydraulic flow to the pump, damage will occur. (See Set-Up Instructions in the pump manual.)

The PWM valve controls the hydraulic flow to the pump, which creates a variable rate pump. With the PWM valve, the pump controls the rate of fertilizer flow.

**⚠ WARNING - Not a suitable pump for flammable liquids.**



## Hand Wash Tank

Nine gallon capacity hand wash tank, which includes built in toolbox, makes cleaning hands after chemical spills quick and easy. At the end of the season, winterize the hand wash tank by entirely draining the water.



## Agitation Valve

If priming becomes an issue, the agitation valve may be opened to allow air to escape from the pump so it can easily be primed.

The agitation valve can also be used to evenly mix additives by running the pump with the electronic control valves closed.

With PWM, the agitation valve may be closed during operation for full pump efficiency.



# Coulter

The number of coulters is determined by the number of rows (usually one less or one more). So the number of rows will be even, and the number of coulters will be odd, since you are placing the nitrogen between the rows. For example, a 24 row unit will have either 23 or 25 coulters. A 24 row applicator with 23 coulters is considered a "one-down" unit. Similarly, a 24 row applicator with 25 coulters is considered a "one-up" unit.



# Counterbalance Valve

The counterbalance valve keeps the outside wings from creeping up. To tighten the counterbalance valve, turn the allen-head on the counterbalance valve closest to the bottom end of the hydraulic cylinder (as shown in the picture to the right) counter-clockwise in 1/2 turn increments until the wings remain locked in place during operation.



# Connecting the Hydraulic Hoses

Connect the hoses so the toolbar raises when the tractor control lever is pulled back and lowered when the control is pushed forward.

Hook up hydraulic lines as follows:

**Set #1 - Green Hoses** - Raise & Lower/ Wing Kick/ Down-pressure

**Set #2 - Black Hoses (No Tape)** - Main Fold

**Set #3 - Red Hoses** - Outside Wing and Stub Wing Fold

**Set #4 - Yellow Hoses** - Hydraulic Pump

**IMPORTANT - For the yellow hoses, hook the 3/4" return hose (pump hose without yellow tape) to a low pressure return port on the tractor.**

**If you have a 750 pump, hoses with have high flow pioneer ends.**

**Be sure to use the hose without the yellow tape to the low pressure return port on the tractor.**

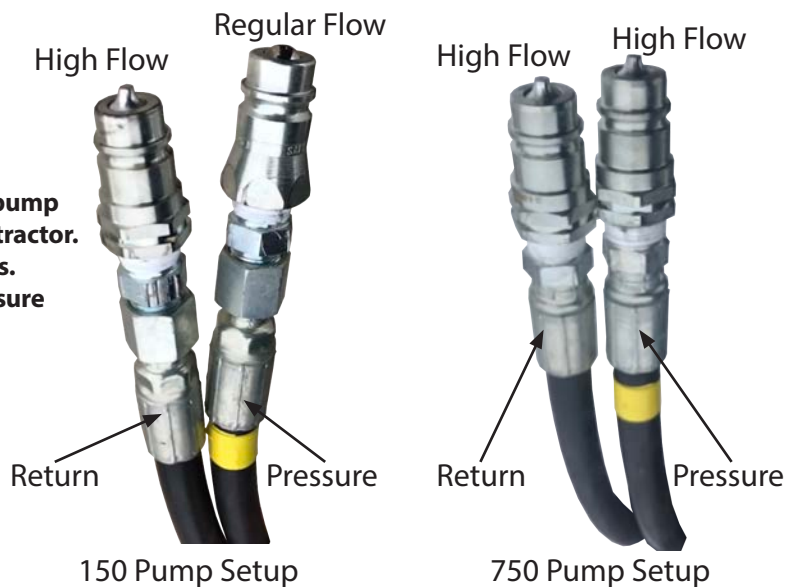

# Hitching and Unhitching the Applicator

Connect the applicator to the tow vehicle using a hitch pin and make sure a retaining pin is secured in the hitch pin. Always attach the safety chains to the applicator and the tow vehicle.

**⚠ WARNING** – Before unhooking the applicator, empty contents from tank, block wheels, unpin the jack from storage position, and lock it in the usage position. Lower the jack stand to the ground until the weight of the applicator is transferred to the jack. Keep hands and feet away from the jack stand when lowering.

Remove the hitch pin and unhook the safety chains.

**⚠ WARNING** – Always relieve hydraulic system pressure before disconnecting hoses from tractor or servicing hydraulic system. See the tractor's operating manual for proper procedures. Disconnect the hydraulic hoses. Install dust covers over the hose plugs and outlets.

When not in use, the jack handle is stored under the tongue, as pictured to the right.

When not in use, lock the stub wings in place by shutting off the hand valves located at the base of each stub wing cylinder. This will keep the stub wings from unfolding when temperatures fluctuate and cause thermal expansion in the hydraulic system.

**⚠ WARNING** – Failure to close the valves may cause damage to the applicator's surroundings.

## Adjusting the Hitch Height

If the front of the toolbar is higher than the rear, raise the hitch a set of holes on the front of the tongue. If the rear of the toolbar is higher than the front, lower the hitch a set of holes. Shims can be used under the hitch and above the tractor drawbar to adjust the level more if moving the hitch between holes is too big of an adjustment. Shims will raise the front of the toolbar up.

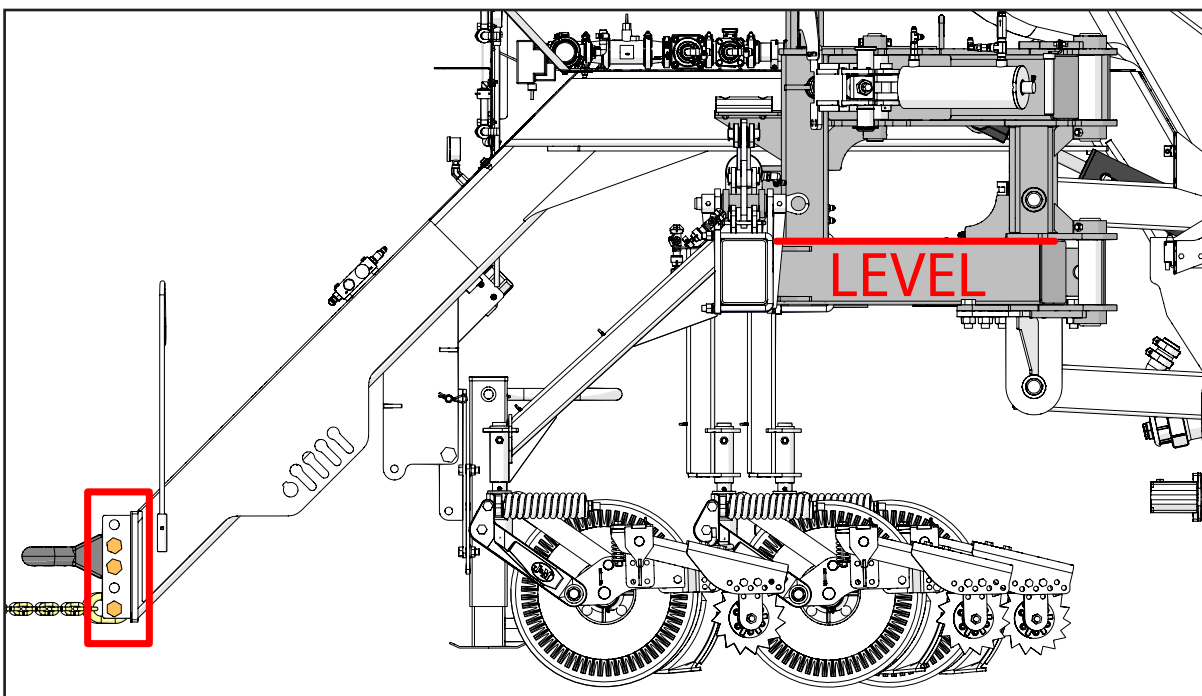
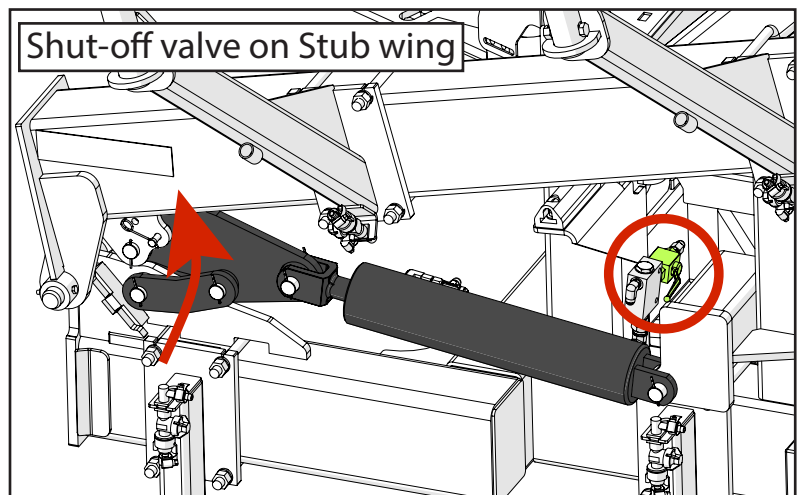
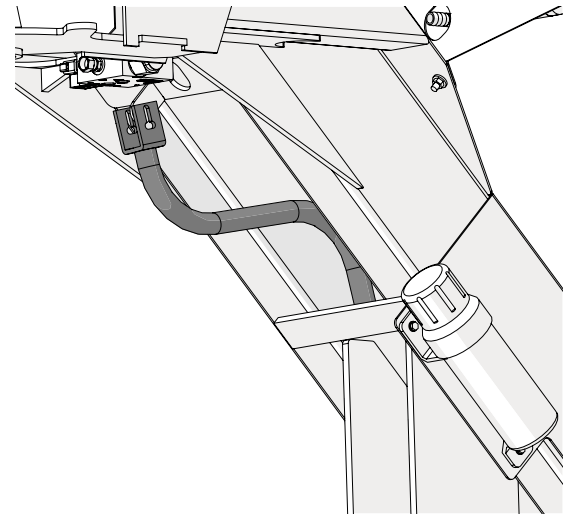



# Initial Operation

Follow these maintenance guidelines during the initial operation of your NitroGro applicator.

First 30 minutes of operation:

1. Ensure all coulters and nozzles are clean and working properly. Clean and adjust accordingly.
2. Check all hydraulic and chemical lines. Be sure none of them are kinked, pinched or leaking. Adjust lines accordingly.
3. Re-torque all of the wheel bolts.
4. Check all other fasteners and hardware. Adjust accordingly.
5. Lubricate all grease fittings.
6. Ensure that outside wings are not creeping up. If needed, adjust the counterbalance valves. Refer to "Counterbalance Valve" on page 15 for instructions.

After 4 hours of operation:

1. Ensure all coulters and nozzles are clean and working properly. Clean and adjust accordingly.
2. Check all hydraulic and chemical lines. Be sure none of them are kinked, pinched or leaking. Adjust lines accordingly.
3. Re-torque all of the wheel bolts.
4. Check all other fasteners and hardware. Adjust accordingly.

After 10 hours of operation:

1. Ensure all coulters and nozzles are clean and working properly. Clean and adjust accordingly.
2. Check all hydraulic and chemical lines. Be sure none of them are kinked, pinched or leaking. Adjust lines accordingly.
3. Re-torque all of the wheel bolts.
4. Check all other fasteners and hardware, especially the U-bolts that secure the coulters to the toolbar. Tighten if needed.

Upon completing the initial break-in period, begin the standard maintenance schedule as described in "Service" on page 26.

# Folding & Unfolding

## Unfolding

1. Toolbar Completely Up  
(Down Pressure Circuit - Green Taped Hoses)

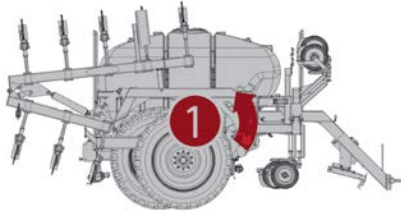

2. Main Toolbar Forward and **Allow Locks to Fully Engage**. Hold hydraulics for 5 seconds once wings fold completely forward. (Toolbar Fold Circuit - Non-Taped Hoses) To be sure locks are fully engaged, and make sure the arrow is aligned for the latches on both sides before field use.



**WARNING: Failure to allow locks to fully engage, as pictured below, can cause severe damage to the applicator. Look at the align arrows decal before field use.**

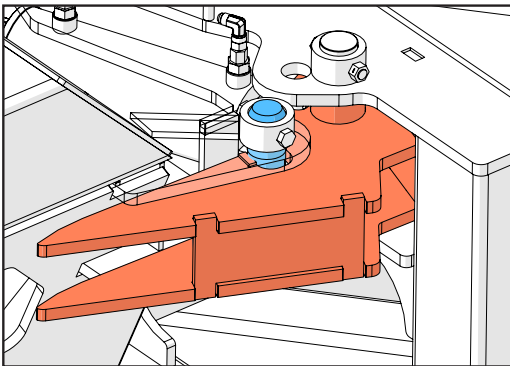
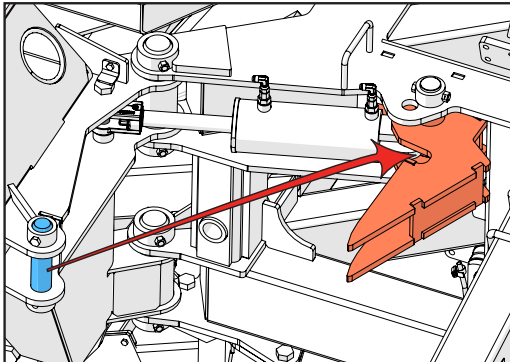

3. Flip Toolbars Out  
(Toolbar Flip Circuit - Red Taped Hoses)

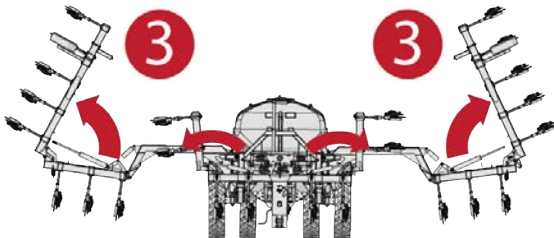

## Folding

1. Toolbar Completely Up  
(Down Pressure Circuit - Green Taped Hoses)



2. Flip Toolbar In  
(Toolbar Flip Circuit - Red Taped Hoses)

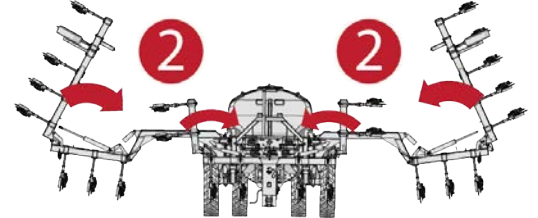

3. Main Toolbar Backwards  
(Main Toolbar Fold Circuit - Non-Taped Hoses)

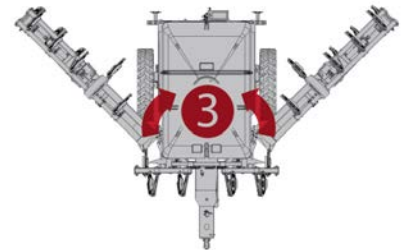

4. Main Toolbar Down  
(Down Pressure Circuit - Green Taped Hoses)

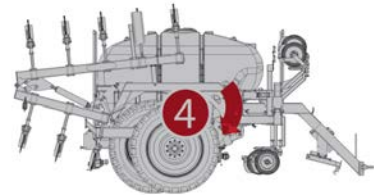

**WARNING: Ensure wings are resting in wing saddles before transport (as pictured below).**

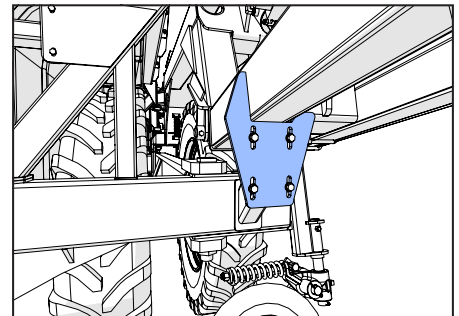

# Electric Switches

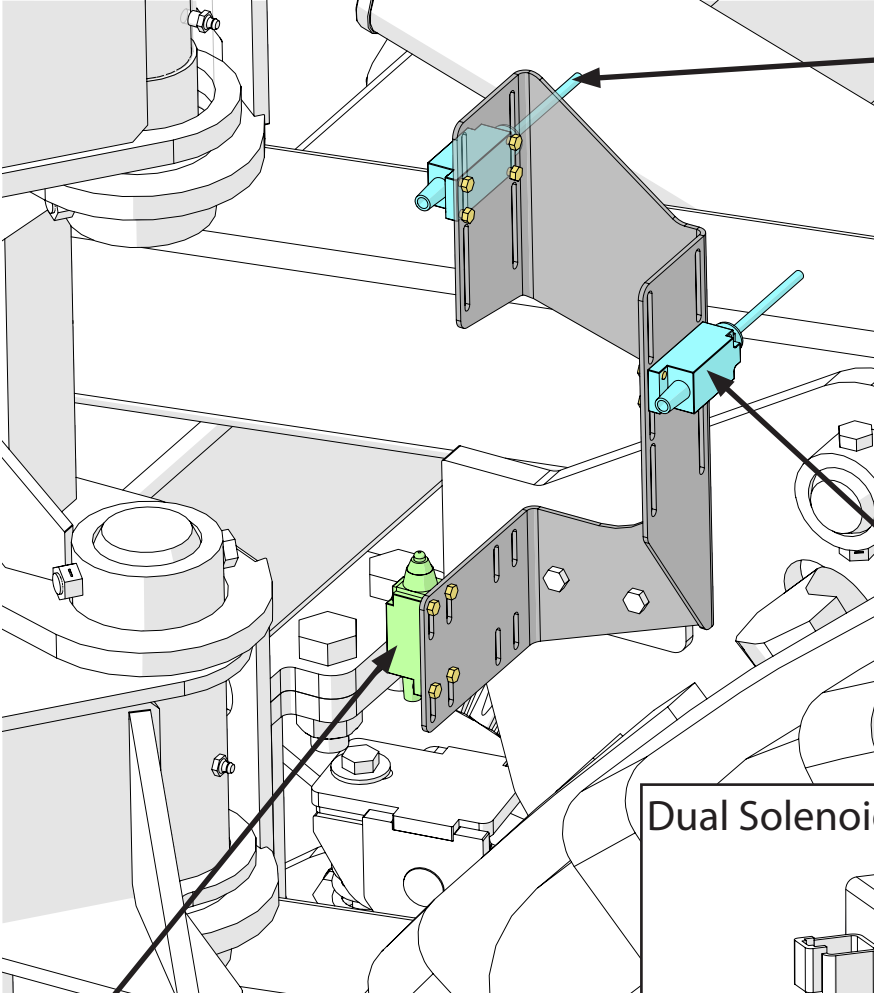

Momentary whisker switch for latch/folding circuit. The height of this switch should be set so that it gets pressed by the parallel arm when the toolbar is completely raised up. It should be plugged into the side of the dual solenoid valve with number 3 and 4 ports (side B). The wire leads coming from side B should be wired to the switch in the normally open position.

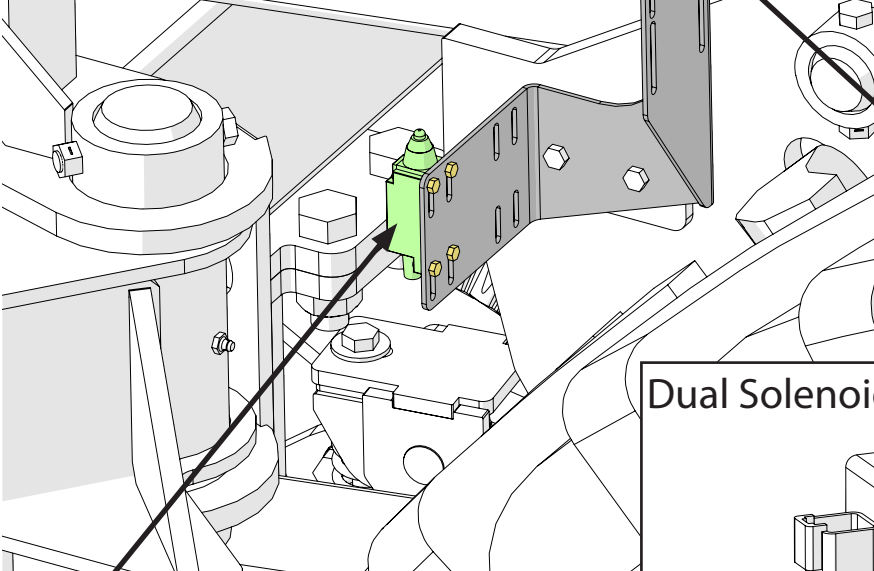

Momentary whisker switch for fertilizer flow on/off. The height of this switch should be set so that it gets pressed by the parallel arm at the toolbar height that you want the fertilizer pump to shut off. It should be wired in the normally closed position. Wires go to the fertilizer controller.

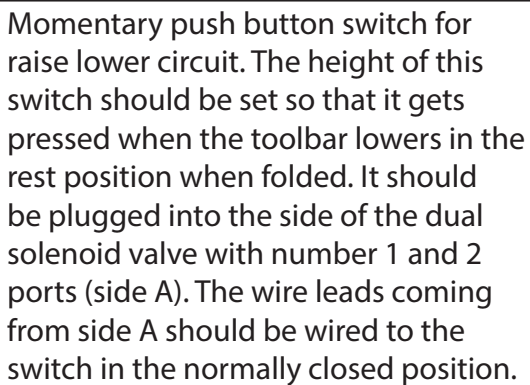

Momentary push button switch for raise lower circuit. The height of this switch should be set so that it gets pressed when the toolbar lowers in the rest position when folded. It should be plugged into the side of the dual solenoid valve with number 1 and 2 ports (side A). The wire leads coming from side A should be wired to the switch in the normally closed position.

### Dual Solenoid Valve

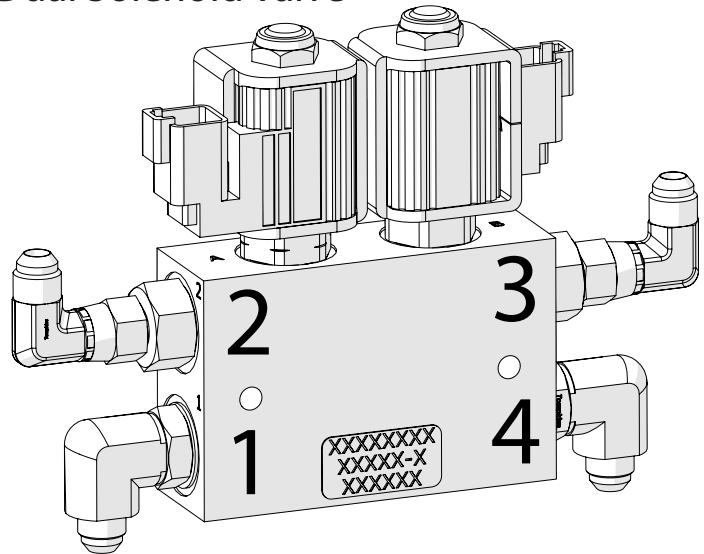

# Adjusting the Field Depth

1. All the cylinder rod spacers used for setting the coulters soil depth of the center section should be installed on the 4"x12" lift cylinders on the center toolbar, shown below.

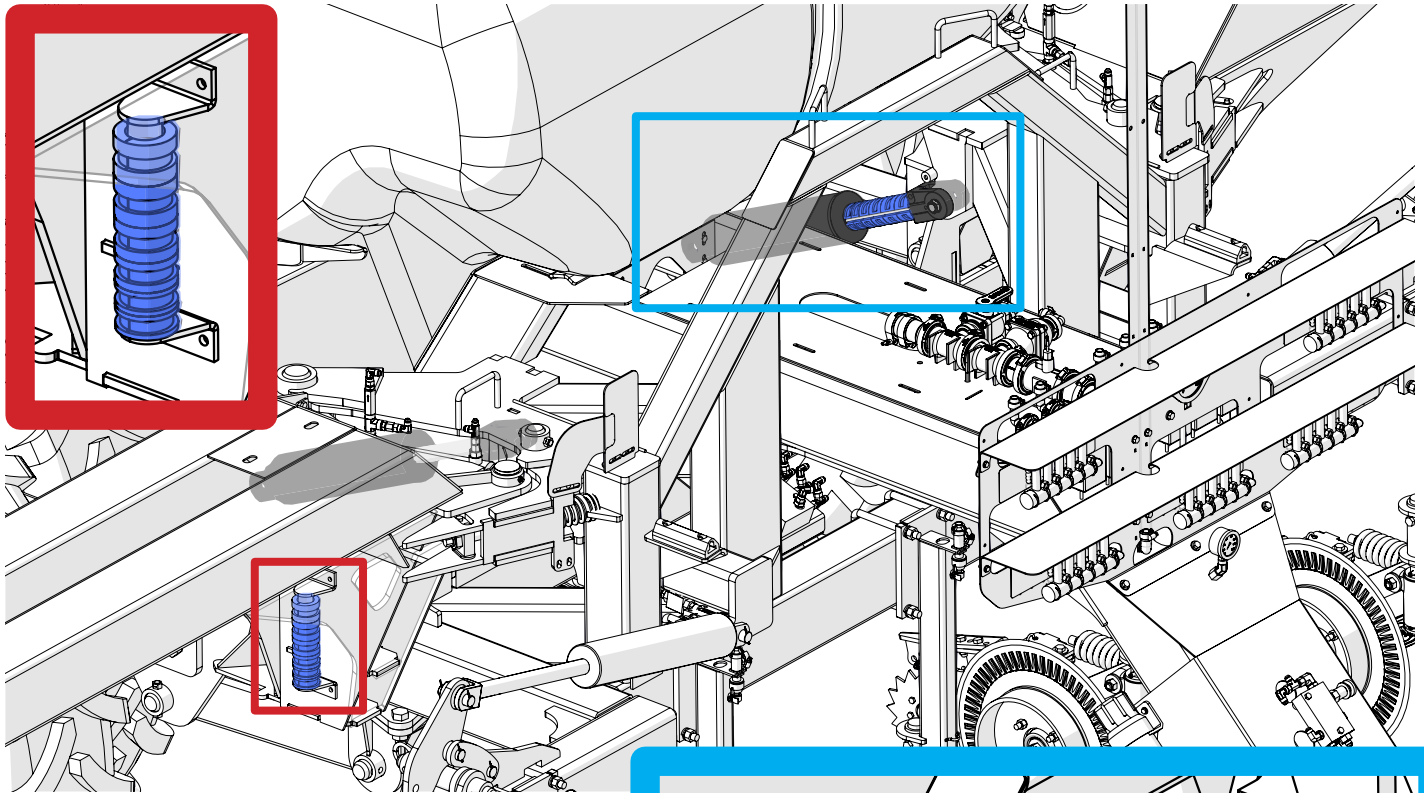

2. With the toolbar unfolded, lower the toolbar and leave it in detent, applying constant downward pressure to the 4"x12" cylinders.
3. Pull the applicator forward for 20-30 yards to allow the coulters to reach their maximum soil depth and stop.
4. If more depth is desired for the center section of the toolbar, remove a cylinder spacer of the same width from each 4"x12" cylinder. Again, pull forward 20-30 yards before rechecking the depth. Repeat this process until the coulters on the center section of the toolbar are at the correct soil depth. The unused spacers can be stored on the underside of the first inside wings on either side of the applicator, shown below.

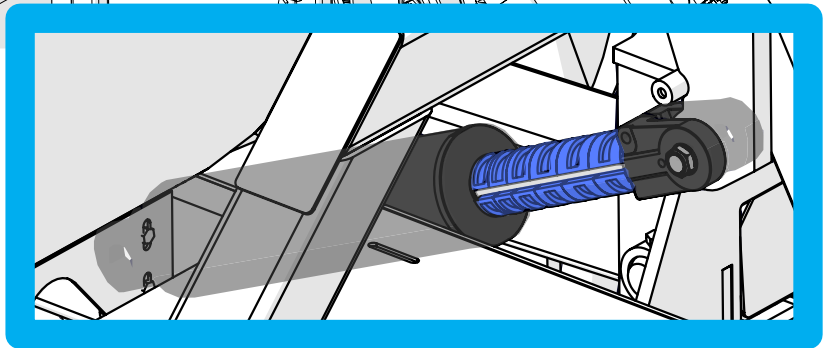

5. After the correct depth is set for the coulters on the center toolbar section, each of the gauge wheel assemblies can be adjusted up or down in order to set the coulters depth of the outside wings. This can be done by simply removing the hair pin and depth control pin on each gauge wheel assembly, shown below. After each gauge wheel adjustment, pull the applicator forward 20-30 yards before checking the wing coulters depth, until the correct soil depth is achieved. All four gauge wheel assemblies should be set to the same height to ensure the toolbar is level
- NOTE:** If at any point the 4"x12" cylinders are not bottomed out on the rod spacers or the gauge wheels are not on the ground while moving, increase the down pressure relief valve pressure by referring to the next section.

**NOTE:** Changing field conditions like soil type and moisture levels can change the down pressure and depth setting requirements. Check the coulters depth when field conditions change and adjust accordingly. Coulters depths of over 5" are not recommended for 28% or 32% UAN applications. Coulters depths greater than 5" can also cause damage to the applicator and will void the manufacturer's warranty.

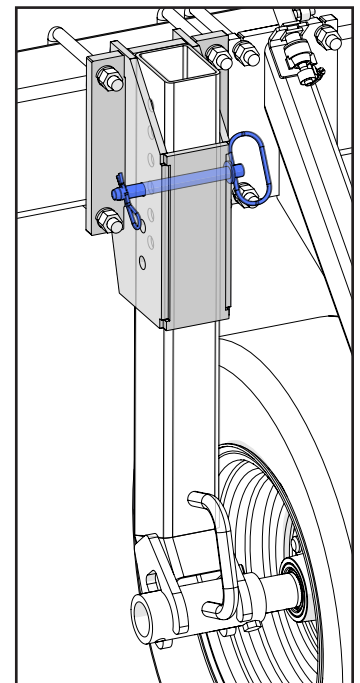

o\_6018\_6026



# Operation

1. Hook tractor to NitroGro and adjust hitch so that the toolbar on applicator is level or tilting forward slightly. See "Hitching and Unhitching the Applicator" on page 16.
2. Connect hydraulic lines. See "Connecting the Hydraulic Hoses" on page 15.
3. Unfold the unit. See "Folding & Unfolding" on page 18.
4. Set the coulter depth. See "Adjusting the Field Depth" on page 20.
5. Using the desired rate of application (GPA) and speed of application (MPH), reference the supplied sizing charts beginning on page 32 of this manual to determine which orifices or injectors will provide optimal application pressure. Install the orifices or injectors in the check valve unit above each row unit that is mounted on the coulter shaft.  
**NOTE – The unit will be either be set up to skip a row ("1 Down"), or re-apply the outside row ("1 Up").**
  - **If the unit is set up as "1 Down" (23 or 35 coulters), then the outside coulters on each end of the unit will be 1.5x the rate of the other coulters.**
  - **If the unit is set up as "1 Up" (25 or 37 coulters), then the outside coulters on each end of the unit will be 0.5x the rate of the other coulters.**
6. Check to make sure tank is clean of all debris inside. Remove any and all debris.
7. Put 200 gallons of water in the tank and check for leaks.  
**IMPORTANT - Before proceeding to the next step, ensure that both the maintenance valve under the tank and the agitation valve is open to allow the pump to prime. NEVER run the pump dry. Doing so will void the manufacturer's warranty.**
8. With the maintenance valve open, perform initial setup of the pump as outlined in the pump operator's manual. After pump set up, recheck the applicator for leaks. For pump setup see "Hydraulic PWM Pump" on page 14.
9. Adjust the hydraulic down pressure. See "Down Pressure Relief Valve and Gauge" on page 13.  
**IMPORTANT - DO NOT exceed 1,350 psi.**
10. Adjust hydraulic flow on the raise and lower/wing kick/down-pressure circuit with the least amount of hydraulic pressure necessary while maintaining a reasonable speed to raise and lower the toolbar. This will prevent excess heat in the hydraulic system as this circuit provides continuous toolbar down-pressure.
11. Fold the wings up for transport. See "Folding & Unfolding" on page 18.  
**IMPORTANT - Be sure to fully raise the toolbar before folding the wings up! Failure to do so will result in damage to the unit.**
12. **TIRE PRESSURE:** The following is to be used as a **general guide** for tire inflation for cyclic use. Figures can vary depending on specific brand of tire used. **It is important that tires are inspected before and after operation. The tire should stand up with no side wall buckling or distress as the tire rolls. Do not exceed the tire pressure indicated below:**

6018 Tires for Single Wheel Applicators	psi
VF320/105R46 (Alliance) (172D)	71
VF380/90R46 (Alliance) (173D)	57
IF520/85R42 (Alliance) (169D) (21"Width)	31

6018 Tires for Walking Tandem Dual Wheel Applicators	psi
VF320/105R46 (Alliance) (172D)	20
VF380/90R46 (Alliance) (173D)	17
IF520/85R42 (Alliance) (169D) (21"Width)	11

6026 Tires for Walking Tandem Dual Wheel Applicators	psi
VF320/105R46 (Alliance) (172D)	29
VF380/90R46 (Alliance) (173D)	25
IF520/85R42 (Alliance) (169D) (21"Width)	16

Tires for Gauge Wheels	psi
ST215-75D14 Carlisle Sport Trail Tire	45

# Raven 450 Controller Set Up

## Initial Console Programming

**HINT: If you enter the wrong value when entering your data press "ENTER" then press "ENTER" again and re-enter your value again.**

- Select the unit of measurement by pressing the CE button until the desired selection appears in the display and press "ENTER"  
**NOTE - The unit of measurement for the United States is Volume per Acre.**
- Select the type of sensor by pressing the CE button until the desired sensor type appears in the display and press "ENTER".  
**For Phoenix 10, select SP2.**  
**For wheel drive sensor, select SP1.**
- The message "CAL C-SD STANDARD VALVE" will appear in the console's display.  
**For PWM pump, press CE until C-P-C PWM appears. Press "ENTER".**
- The message "CAL SELF TEST 00" will appear in the console's display. Press the "BOOM CAL 1" button and enter the value shown in the table below. To store the values, press "ENTER" (the enter button will light up), input the value and then press "ENTER" to store your value. Repeat for Boom 2 through 5. Press the arrow keys to advance to the remaining booms.

Boom #	Value
Boom 1	135
Boom 2	150
Boom 3	150
Boom 4	150
Boom 5	135

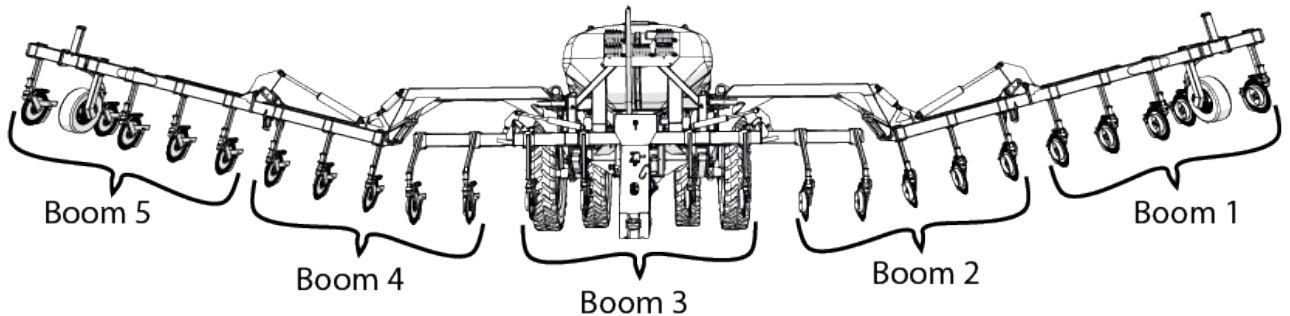

- Press the "SPEED CAL" button and input the appropriate speed calibration value for the type of sensor being used and press "ENTER".  
**For Phoenix 10, the speed calibration is 785.**  
**For wheel drive sensor, refer to the speed calibration steps in the Raven SCS 450 operator's manual.**
- Press the "METER CAL" button and enter the meter calibration value stamped on the flow meter's identification tag.  
**The meter calibration value is approximately 1,340 gallons. Check the stamped valve to be sure.**
- Press the "VALVE CAL" button and input the calibration number that corresponds with the control valve being used and press "ENTER".  
**For PWM Pump, the valve calibration is 0043 or 43. If the pump does not react fast enough to the desired rate, 33 can be entered here to speed up the controller's reaction time.**
- Press the "RATE 1 CAL" button and "ENTER" the Rate 1 value. Refer to the "Calculate the Rate 1 and Rate 2 Cal Values" section of the Raven SCS 450 manual and press "ENTER".
- Press the "RATE 2 CAL" button and "ENTER" the Rate 2 value. Refer to the "Calculate the Rate 1 and Rate 2 Cal Values" section of the Raven SCS 450 manual and press "ENTER".
- The initial console programming is now complete, and the flashing "CAL" in the console's display should turn off. If it does not, repeat the procedure starting from the first step above.
- These settings will be stored and the previous steps do not need to be repeated after powering off or on.
- Adjust the PWM offsets by selecting "Data Menu" and use the arrows to find the high PWM and Low PWM offsets. Set the high PWM offset to 220 and the low PWM offset to 50. Next, find the PWM frequency and set it to 122.

**RESET:** If an entry or selection error is made during any steps of this procedure, turn the POWER switch to the OFF position, press and hold CE while turning the POWER switch to the ON position to reset the console.



# Raven ISOBUS Rate Controller Set Up

- On the second tab from the left, enter the Flowmeter Calibration (Meter Cal) number, approximately 1,340, which is stamped on the flowmeter on the applicator.
- Next select Valve Cal. Here, a Self Test speed can be entered for water testing and a nozzle flow check.

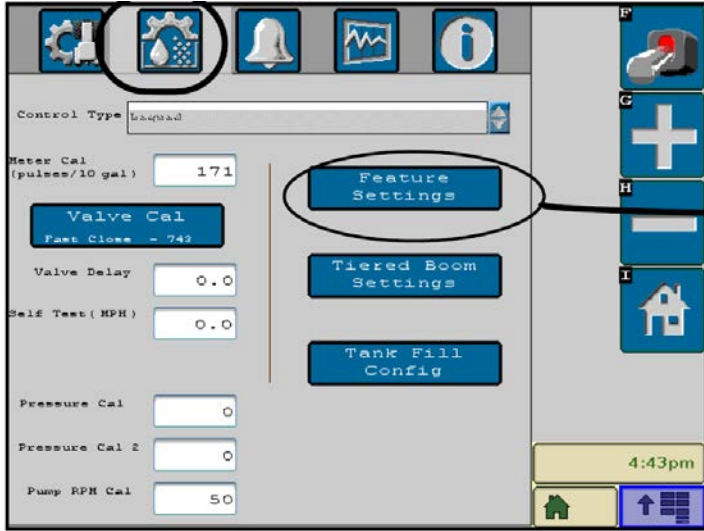

- For Valve Type, select PWM Closed.
- Enter 43 for the Valve Cal.  
If the pump does not react fast enough to a desired rate, 33 can be entered for the Valve Cal speed up the reaction time.
- Enter 220 for the Max PWM, 50 for the Min PWM and 122 for the PWM Frequency. Select Ok.

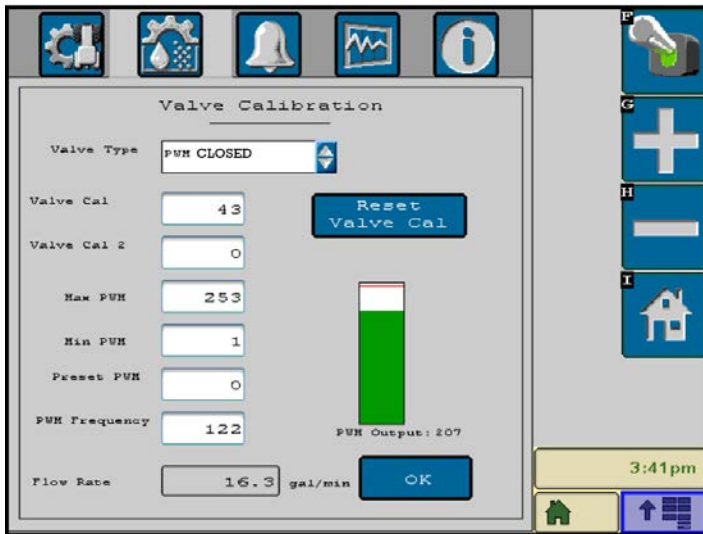

# John Deere Greenstar Rate Controller PWM Setup

In the System Set-up Tab, select **"3-Wire" (C)** for the Section Valve Type. See your Nitrogro Owners Manual for information on the number of sections and section widths.

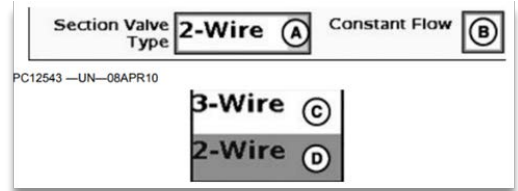

In the System Set-up Tab, select **"PWM Close" (F)** for the Control Valve Type.

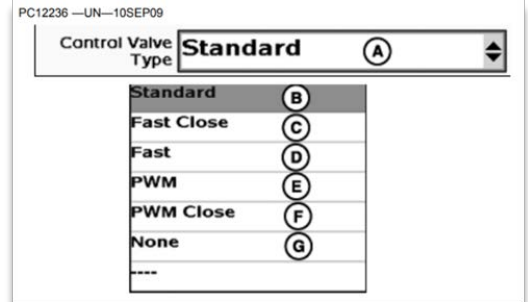

Select the PWM Setup Button to enter into the PWM Settings Box. In the PWM Settings Box, enter a Control Valve Calibration of **1533**, a Coil Frequency of **122**, a High Limit of **220** and a Low Limit of **50**. The High and Low Limits can be fine tuned using the Calibrate PWM Limits button to speed up the response time if necessary.

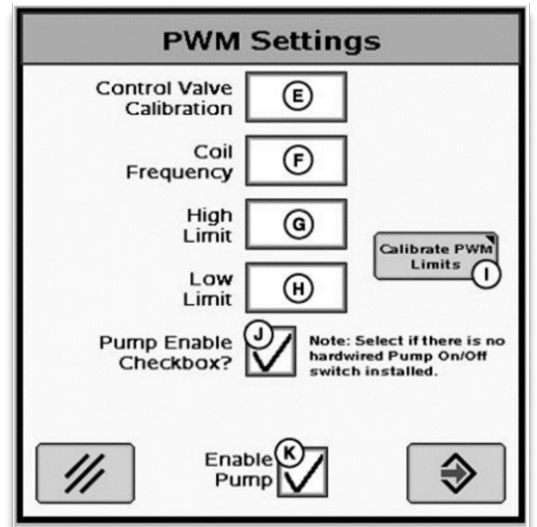

Enter the Flowmeter Calibration number, approximately 1,340, which is stamped on the flowmeter on the applicator. Also check and make sure the units are the same as stamped on the flowmeter, usually Gallon **"10 gal" (H)**.

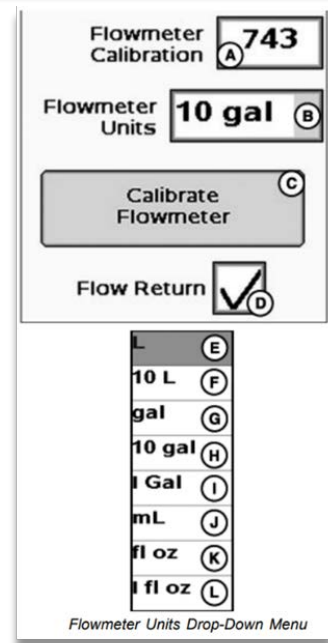

See your Greenstar Rate Controller Manual for more details.



# John Deere Rate Controller 2000 PWM Setup

On the Setup Sections page, select **"3-Wire"** for the Section Valve Type. See "Flow Monitor Set Up" on page 30 for information on the number of sections and section widths.

PC22302—UN—21MAR16

On the Setup Control Valve page, select **"PWM Close"** for the Control Valve Type. Enter **"50"** for the Valve Response Rate and **"2"** for the Control Deadband.

PC22311—UN—22MAR16

On the Setup PWM page, enter **"122"** for the Coil Frequency, **"85"** for the High Limit %, **"20"** for the Low Limit % and **"0"** for the PWM Startup %.

PC22362—UN—29MAR16

Enter the Flowmeter Calibration number, approximately 1,340, which is stamped on the flowmeter on the applicator. Also check and make sure the units are the same as stamped on the flowmeter, usually Gallon **"10 gal" (H)**.

PC22312—UN—22MAR16



See your Rate Controller 2000 Manual for More Details

o\_6018\_6026





# Transporting

- Comply with ALL state and local laws governing highway safety and regulations when moving machinery on public roads.
- Be sure an SMV (Slow Moving Vehicle) emblem is in place and clearly visible on the rear of the applicator. Position the SMV emblem with one point of the triangle upward and as near to the rear and centered or as near to the left of center of the unit as practicable. Secure the SMV emblem two to ten feet above the ground measured from the lower edge of the emblem. Before transporting, ensure that all lights, reflectors, and the SMV emblem are clean and visible. Ensure the amber, red, and orange reflective tape on the implement is in place and clearly visible. Before transporting, ensure all lights, reflectors, and the SMV emblem are clean and visible.
- When transporting applicator, do not exceed 10 MPH in the field or over rough terrain. For highway transportation, do not exceed 20 MPH. Reduce transport speed when necessary to maintain full control. **Never transport the applicator with contents in the tank.**
- Tongue weight when NitroGro is folded and empty for road transport is 600-1,000 lbs depending on the configuration. Negative tongue weight (even intermittent) may cause instability when transporting. Add ballast to tractor as required. Never tow this implement with a motor vehicle. Tow only with a properly ballasted tractor.
- Be aware of overhead wires when transporting.
- Ensure the safety chain has a rating greater than the empty weight of the machine.
- Ensure wings are seated in the transport saddles before transporting.

# Service

To prolong the life of your NitroGro applicator, perform the following on a regular basis:

1. Grease coulters hubs with two pumps every 50 hours.
2. Grease row closers (if equipped) 1 pump of grease per year.
3. Grease main wing fold pivots and walker pivots every 50 hours as shown in the picture below. There are two grease points on each side of the main wing fold (4 total). If duals are equipped, there are 1 on each side of the unit for the walking pivots.

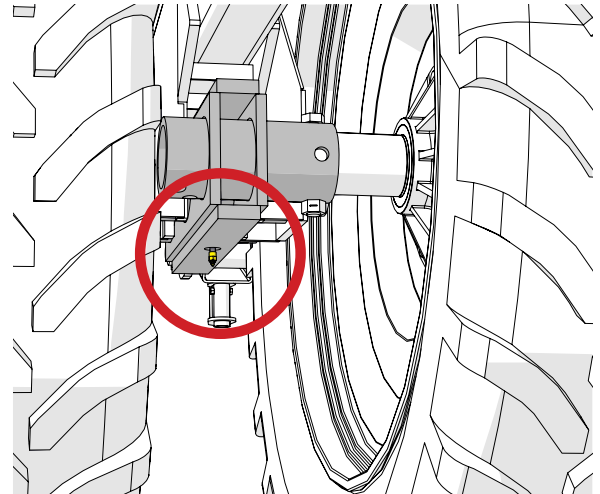
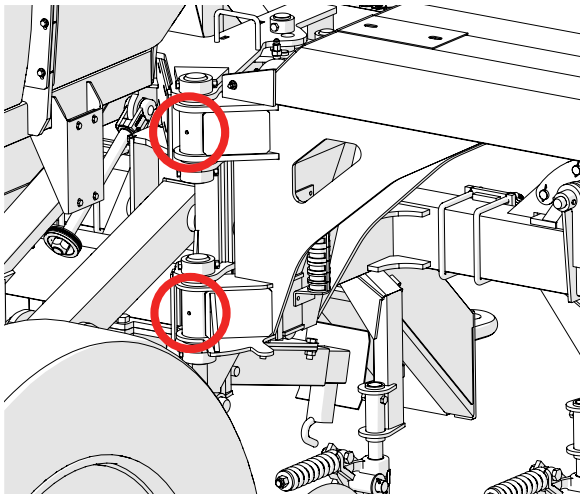

4. Check lighting before over the road transport. Make sure lights and SMV emblem are clean from dirt and field debris.
5. Check implement for damage, cracked welds, loosened hardware, etc. After the unit is repaired promptly repaint to prevent further damage.
6. Check hydraulic system for leaks and hose damage, twists or kinks and repair as needed.
7. Check fertilizer handling system for leaks and hose damage, twists or kinks and repair as needed.
8. Check tire pressures and lug nuts periodically and adjust as required.
9. Grease wheel hubs.
10. Grease jack every 50 hours.
11. Clean strainer daily.
12. Repack bearings for both the gauge wheel hubs and main wheel hubs each season.
13. Grease the main lift cylinder pins (4 total) every 500 acres.
14. Grease latch spinning joints on wings (4 total) every 1000 acres.

# Storage

To prolong the life of your NitroGro applicator, hook the applicator to a tractor, unfold it, and perform the following before placing the implement in storage:

1. Pressure wash the NitroGro applicator to remove dirt and debris that may cause rusting.
2. Repaint any areas where the paint has been chipped, scratched or worn away.
3. Coat all earth-moving surfaces with a suitable rust preventative.
4. Inspect for damaged or worn parts and replace before next use. Examine all hydraulic hoses and fittings for wear and replace or tighten as necessary.
5. Grease couler hubs.
6. Replace all worn, torn, or faded decals and reflectors.
7. Flush all fertilizer from the system and winterize the applicator if kept in cold storage.

**IMPORTANT - To winterize your NitroGro drain the tank and all fertilizer hoses. Once the system is drained add approximately 50 gallons of RV antifreeze. Run the antifreeze thru the strainer, valves, check valves, and orifices until antifreeze comes out of all knives/orifices.**

8. Cover flow monitors from the sunlight. If flow monitors are exposed to the sun for a long period of time they will turn cloudy and become difficult to see through.
9. Store the implement inside and sheltered from inclement weather on an area that is dry, level, and clear of debris.
10. Fold up applicator and unhook from tractor.
11. When not in use, lock the stub wing in place by turning the shut-off valve off on the stub wings. This will keep the stub wings from unfolding when temperatures fluctuate and cause thermal expansion in the hydraulic system.

Do NOT use anything except RV antifreeze to winterize. Using anything else can cause severe damage to fertilizer distribution components and will VOID warranty.

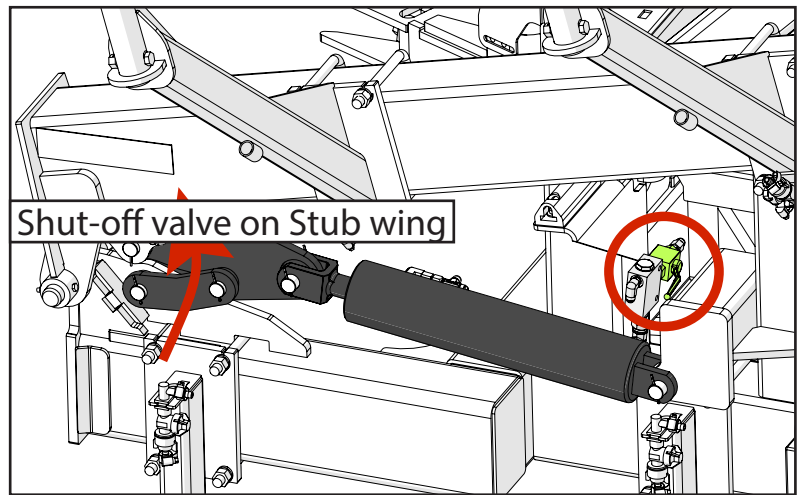

# Removing Pump Safety Plugs

Loosen the stainless clamps shown below and remove the safety plugs. Then, attach the pump fittings using the stainless clamp, ensuring the gasket is seated correctly between the pump and pump fittings. Failing to remove these plugs can cause the pump to run dry and cause damage. Once the pump safety plugs are removed, the applicator will need to be winterized before freezing temperatures occur. See "Storage" on page 27.

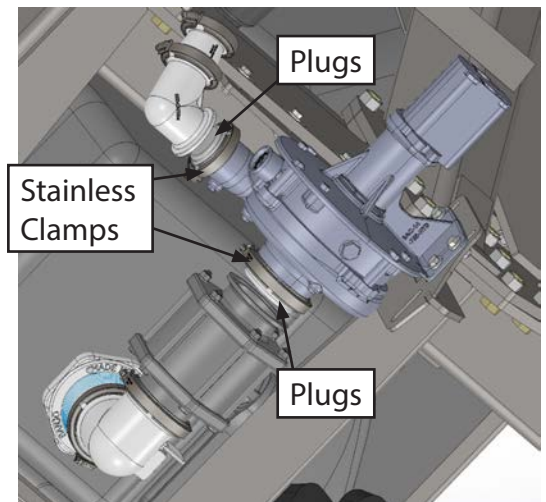

# Troubleshooting

**⚠ WARNING - MAKE SURE THAT ALL POWER IS SHUT OFF BEFORE SERVICING THE APPLICATOR. MAINTENANCE AND REPAIR SERVICE WORK TO BE PERFORMED BY QUALIFIED SERVICEMEN ONLY.**

Trouble	Possible Cause	Possible Remedy
Outside tool bar wing creeps up over time	Counterbalance valve is too loose	Tighten counterbalance valve. See "Counterbalance Valve" on page 15 for instructions.
Toolbar will not raise or lower/ Wings will not fold or unfold	Faulty hydraulic coupler	Replace with new coupler.
Toolbar will raise out of transport position but will not go back down or not fold wings out	No power to the dual solenoid valve	<ul style="list-style-type: none"> <li>• check for blown aux fuse on tractor</li> <li>• check for pinched wires/bad connection</li> <li>• check to see if switch #1 is triggered when toolbar is completely up</li> <li>• light harness not hooked up</li> </ul>
Center toolbar section too deep or too shallow	Center lift cylinders have improper combination of cylinder spacers	Add or remove spacers as necessary.
Wings are tilted up from center toolbar section	Gauge wheels set too low	Move gauge wheels up.
	Hydraulic down pressure not set high enough	Increase pressure by turning adjustment knob clockwise. <b>IMPORTANT: Do not exceed 1,350 psi.</b>
	Center toolbar section set too deep	Add cylinder spacers to lift cylinders.
Wings are tilted down from center toolbar section	Gauge wheels set too high	Move gauge wheels down.
	Center toolbar section set too shallow	Remove cylinder spacers from lift cylinders.
Fertilizer pressure gauge showing high pressure when applying fertilizer	Orifices too small	Install larger orifices.
	Plugged knives	Clear debris.
	Kinked hoses	Adjust hoses as necessary.
	Speed too fast	Slow down.
	Flow monitor balls installed incorrectly	Install flow monitor balls below plastic grate under flow monitor cap. One ball per flow monitor.
Unable to maintain set application rate	Clogged strainer	Clean strainer.
	Orifices too small	Install larger orifices.
	Agitation valve too far open	Adjust valve as necessary.
Fertilizer pump will not prime	Tank valve closed	Open valve.
	Agitation valve closed	Open valve.
Stub wing unfolding itself when not in use	Temperature variations causing expansion in hydraulic system	Use shut-off valves installed on base of each stub wing cylinder.
Outside wing sections creeping up. The 4x24 cylinder is retracting under pressure	The counterbalance valve needs tightened	See "Counterbalance Valve" on page 15.

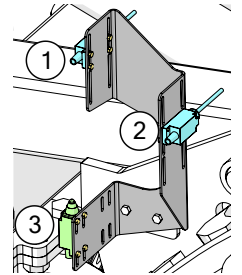



# Troubleshooting

## HIGH BACK PRESSURE IN THE RETURN LINE:

This is the most common cause of shortened motor seal life. The hydraulic motor seal is rated for 250 psi of back pressure. However, a continuous return pressure of 100 psi or less is recommended for efficient operation and optimum seal life. The high return pressure is caused by restrictions in hoses, fittings, and tractor plumbing.

### LOOK FOR:

Seal lips pressed tight against the outer seal housing and shaft. There may also be grooves in the shaft where the seal lips touch.

### PREVENTION:

The best way to minimize return pressure is to return oil directly back to the tractor reservoir. Most tractor manufacturers now offer a Low Pressure Return Port option for this purpose. Contact your dealer for the specific options available for your tractor model. Proper hydraulic hose sizing is also important to minimize restriction. An open hose coupling may also be used to reduce restrictions in the return line. Ace recommends 1/2" hose for 200 Series motors and 3/4" hose for 300 series motors. The hoses should be sized larger if individual lengths exceed 15 feet.



## PRESSURE SPIKE:

System pressure spikes may also damage the shaft seal and cause leakage. Spikes in the 3000-5000 psi range may result from improperly synchronized hydraulic valves or quick couplers coming unplugged during operation.

### LOOK FOR:

The seal lips are pressed tight against the outer seal housing and form a right angle between the seal housing and the shaft. In severe cases, the seal lip material may be extruded between the front seal casing and the shaft.

### PREVENTION:

Using a Low Pressure Return Port prevents spikes by keeping the return line open back to the reservoir at all times. If not using a low pressure return, the pump should always be turned off by moving the lever to the Float position. When moved to Float, the oil supply valve is shut but the return valve stays open.



\*Refer to the ACE hydraulic pump manual or Raven controller manual for additional troubleshooting information.

## Adapter Harnesses for Various Controller Options

If you want to use a different controller for your applicator than Raven you may need to get an adapter harness from these manufacturers below.

Controller	Adapter Harness	Adapter Part #	Source
JD Rate Controller 2000	RC2000 to Raven New Style Flow Harness (16 Pin)	AE2967	Ag Express
JD Rate Controller	JDRC to Raven New Style Flow Harness (16 Pin)	AE3170	Ag Express
Trimble Field-IQ	Field-IQ to Raven New Style Flow Harness (16 Pin)	AE2923	Ag Express
Ag Leader	Raven Adapter Harness	4001266	Ag Leader
TeeJet	Harness, IC18 to Raven Flow Control Implement Harness	45-10122	TeeJet

# Flow Monitor Set Up

The NitroGro applicator offers row spacing options of 20", 22", or 30". The unit will either be set up to re-apply the outside row ("1 Up"), or skip a row ("1 Down"). Using your row spacing and whether your applicator is "1 Up" or "1 Down", refer to the chart below to determine the location and quantity of flow monitors for your applicator.

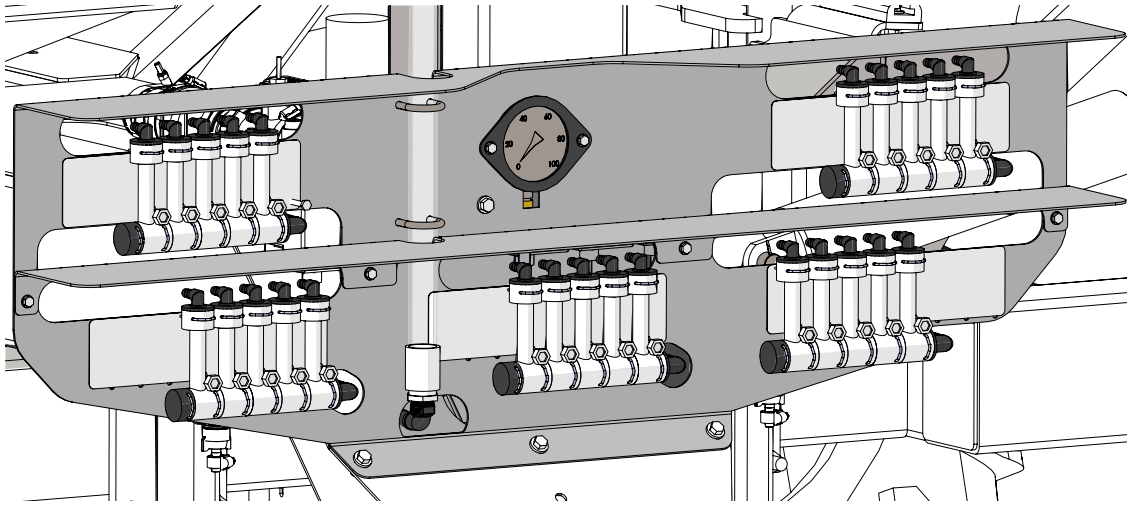

Row Spacing	Flow Monitor Manifold Set Up (1 Up)			Flow Monitor Manifold Set Up (1 Down)		
20"/22"	37 Coulters			35 Coulters		
	8		8	7		7
	7	7	7	7	7	7
30"	25 Coulters			23 Coulters		
	5		5	4		4
	5	5	5	5	5	5

Using the charts on pages 32–43, decide which ball is best suited for your desired GPA and Speed. Only choose one ball for all flow monitors. Remove the balls that are not being used. The easiest way to remove the balls is to remove the flow monitors and dump the balls into a box. During this process, keep the hoses organized to ensure they are returned to their original locations when you reassemble the flow monitors.

To install a ball in the flow monitor, remove the clip and pop off the hose on top of the flow monitor. Remove the screen, insert the ball, and return the screen to its original position. **To prevent the ball from entering the hose, ensure the screen is above the ball.** Clip the hose back onto the flow monitor.

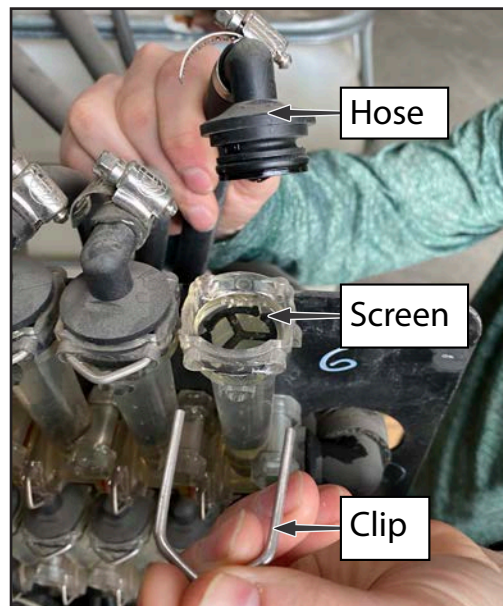

# Changing from 60' to 40' Wing Span

## Changing from 60' to 40'

- Unfold your applicator as normal. Rotate the wings forward and engage the latches.
  - Unfold the outer wings and stub wings enough to place the cylinder stops on the outer wings.
  - Fold the stub wings and outer wing back in.
  - On both 4"x24" cylinders close the valve. This will prevent the cylinder from extending while the stub wings are being folded.
- Note: the cylinder stop allows a gap on the wings so that during use the wings can flex with the contour of the ground.



## Changing from 40' to 60'

- Open the shut-off valve on the 4"x24" cylinders. This will allow the applicator to extend to the full 60 feet.
- Remove the cylinder stop so that it will properly fold when finished.



Scan to watch  
the video



# Injectors - 20" Row Spacing

Speed (MPH)	20 Gallons Per Acre									25 Gallons Per Acre								
	4	5	6	7	8	9	10	11	12	4	5	6	7	8	9	10	11	12
#10 Injector (psi)		1	7	10	15	19	24	29	33	2	6	13	18	24	29	36	41	47
#15 Injector (psi)					3	6	9	12	16			2	5	9	13	17	20	25
#20 Injector (psi)							2	4	7					2	4	8	10	13
#30 Injector (psi)																		2
#40 Injector (psi)																		
GPM (per nozzle)	0.34	0.43	0.52	0.60	0.69	0.77	0.86	0.95	1.03	0.43	0.54	0.64	0.75	0.86	0.97	1.07	1.18	1.29
Flow Indicator 1/2" SS Ball Level	0.6	0.9	1.2	1.5	1.8	2.1	2.4	2.7	3.0	0.9	1.3	1.7	2.0	2.4	2.8	3.1	3.5	3.9
Flow Indicator 7/16" SS Ball Level						0.1	0.3	0.5	0.7					0.3	0.6	0.9	1.1	1.4

Speed (MPH)	30 Gallons Per Acre									35 Gallons Per Acre								
	4	5	6	7	8	9	10	11	12	4	5	6	7	8	9	10	11	12
#10 Injector (psi)	6	12	20	26	33	39	47	53	61	11	17	27	33	42	49	58	66	74
#15 Injector (psi)		1	6.3	10	15	19	24	29	34	1	5	11	15	21	26	32	37	43
#20 Injector (psi)				2	6	9	13	16	20			3	6	11	14	19	22	27
#30 Injector (psi)							1	4	6					1	3	5	8	11
#40 Injector (psi)																	1	3
GPM (per nozzle)	0.52	0.64	0.77	0.90	1.03	1.16	1.29	1.42	1.55	0.60	0.75	0.90	1.05	1.20	1.35	1.50	1.66	1.81
Flow Indicator 1/2" SS Ball Level	1.2	1.7	2.1	2.5	3.0	3.4	3.9	4.3	4.7	1.5	2.0	2.5	3.0	3.6	4.1	4.6	5.1	5.6
Flow Indicator 7/16" SS Ball Level			0.1	0.4	0.7	1.1	1.4	1.8	2.1			0.4	0.8	1.2	1.6	2.0	2.4	2.8

Speed (MPH)	40 Gallons Per Acre									45 Gallons Per Acre								
	4	5	6	7	8	9	10	11	12	4	5	6	7	8	9	10	11	12
#10 Injector (psi)	15	23	33	41	50	59	70	78	88	20	28	40	48	59	69	81	90	102
#15 Injector (psi)	4	8	15	20	28	33	39	45	52	7	12	20	26	34	40	47	53	61
#20 Injector (psi)		1	6	10	15	19	25	29	33		3	10	14	20	24	30	35	40
#30 Injector (psi)					4	6	9	12	15				2	7	9	13	16	20
#40 Injector (psi)							2	4	6						2	4	7	10
GPM (per nozzle)	0.69	0.86	1.03	1.20	1.38	1.55	1.72	1.89	2.06	0.77	0.97	1.16	1.35	1.55	1.74	1.93	2.13	2.32
Flow Indicator 1/2" SS Ball Level	1.8	2.4	3.0	3.6	4.1	4.7	5.3	5.9	6.5	2.1	2.8	3.4	4.1	4.7	5.4	6.1	6.7	
Flow Indicator 7/16" SS Ball Level		0.3	0.7	1.2	1.6	2.1	2.5	3.0	3.4	0.1	0.6	1.1	1.6	2.1	2.6	3.1	3.6	4.1

- NOTES:
- The values highlighted in green indicate pressures that are in the optimal pressure range of 20 - 50 psi. The row spacing is 20 inches.
  - Density or viscosity of the liquid can effect operating range.
  - A displayed pressure higher than the calculated pressure may be due to a pressure drop in the fertilizer hoses.
  - With #10 on the center, use #15 for one and a half rate outside, (35 knife).
  - With #15 on the center, use #8 for half rate outside, (37 knife), and #20 for one and a half rate outside, (35 knife).
  - With #20 on the center, use #10 for half rate outside, (37 knife), and #30 for one and a half rate outside, (35 knife).
  - With #30 on the center, use #15 for half rate outside, (37 knife), and #40 for **one and a third** rate outside, (35 knife).
  - With #40 on the center, use #20 for half rate outside, (37 knife), and #60 for one and a half rate outside, (35 knife).

For replacement injectors, see "Coulter Injector Assembly" in the Parts Manual.



# Injectors - 20" Row Spacing

Speed (MPH)	50 Gallons Per Acre										55 Gallons Per Acre								
	4	5	6	7	8	9	10	11	12	4	5	6	7	8	9	10	11	12	
#10 Injector (psi)	24	33	47	56	68	79	93	103	115	29	39	54	64	77	89	104	115	129	
#15 Injector (psi)	10	16	24	31	40	46	54	61	70	13	19	29	36	46	53	61	69	79	
#20 Injector (psi)	2	6	13	18	24	29	36	41	47	4	9	17	22	29	34	41	47	54	
#30 Injector (psi)			2	5	10	13	17	20	24			4	8	13	16	21	25	29	
#40 Injector (psi)					2	4	7	10	13					4	7	10	13	17	
GPM (per nozzle)	0.86	1.07	1.29	1.50	1.72	1.93	2.15	2.36	2.58	0.95	1.18	1.42	1.66	1.89	2.13	2.36	2.60	2.84	
Flow Indicator 1/2" SS Ball Level	2.4	3.1	3.9	4.6	5.3	6.1	6.8			2.7	3.5	4.3	5.1	5.9	6.7				
Flow Indicator 7/16" SS Ball Level	0.3	0.9	1.4	2.0	2.5	3.1	3.7	4.2	4.8	0.5	1.1	1.8	2.4	3.0	3.6	4.2	4.8	5.5	

Speed (MPH)	60 Gallons Per Acre										65 Gallons Per Acre								
	4	5	6	7	8	9	10	11	12	4	5	6	7	8	9	10	11	12	
#10 Injector (psi)	33	44	60	71	86	99	115	128	143	38	50	67	79	94	109	127	140	156	
#15 Injector (psi)	16	23	33	41	53	60	69	78	88	19	26	38	47	59	67	76	86	97	
#20 Injector (psi)	6	12	20	26	33	39	47	53	60	8	14	23	30	38	44	53	59	67	
#30 Injector (psi)		1	6	10	16	20	25	29	33		3	8	13	19	23	29	33	38	
#40 Injector (psi)				2	6	9	13	16	20			1	4	8	12	16	19	23	
GPM (per nozzle)	1.03	1.29	1.55	1.81	2.06	2.32	2.58	2.84	3.10	1.12	1.40	1.68	1.96	2.24	2.52	2.79	3.07	3.35	
Flow Indicator 1/2" SS Ball Level	3.0	3.9	4.7	5.6	6.5					3.3	4.2	5.2	6.1						
Flow Indicator 7/16" SS Ball Level	0.7	1.4	2.1	2.8	3.4	4.1	4.8	5.5	6.1	1.0	1.7	2.4	3.2	3.9	4.6	5.3	6.1	6.8	

Speed (MPH)	70 Gallons Per Acre										75 Gallons Per Acre								
	4	5	6	7	8	9	10	11	12	4	5	6	7	8	9	10	11	12	
#10 Injector (psi)	42	55	74	87	103	118	138	152	170	47	60	80	94	112	128	149	165	184	
#15 Injector (psi)	22	30	42	52	65	74	84	94	106	25	34	47	57	71	80	91	102	115	
#20 Injector (psi)	11	17	27	33	42	49	58	65	74	13	20	30	37	47	54	64	71	80	
#30 Injector (psi)	1	5	11	15	22	26	32	37	42	2	6	13	18	25	30	36	41	47	
#40 Injector (psi)			3	6	11	14	19	22	27			5	8	13	17	22	26	30	
GPM (per nozzle)	1.20	1.50	1.81	2.11	2.41	2.71	3.01	3.31	3.61	1.29	1.61	1.93	2.26	2.58	2.90	3.22	3.55	3.87	
Flow Indicator 1/2" SS Ball Level	3.6	4.6	5.6	6.6						3.9	5.0	6.1							
Flow Indicator 7/16" SS Ball Level	1.2	2.0	2.8	3.5	4.3	5.1	5.9	6.7		1.4	2.3	3.1	3.9	4.8	5.6	6.5			

NOTE - The values highlighted in green indicate pressures that are in the optimal pressure range of 20 - 50 psi. The row spacing is 20 inches.

# Injectors - 22" Row Spacing

	15 Gallons Per Acre								
Speed (MPH)	4	5	6	7	8	9	10	11	12
#10 Injector (psi)			2	5	9	12	17	20	24
#15 Injector (psi)						1	4	7	9
#20 Injector (psi)									2
#30 Injector (psi)									
#40 Injector (psi)									
GPM (per nozzle)	0.25	0.31	0.38	0.44	0.50	0.57	0.63	0.69	0.75
Flow Indicator Red Glass Ball Level	1.1	1.7	2.2	2.8	3.3	3.8	4.4	4.9	5.5
Flow Indicator 1/2" SS Level	0.3	0.5	0.7	1.0	1.2	1.4	1.6	1.8	2.0

	20 Gallons Per Acre									25 Gallons Per Acre								
Speed (MPH)	4	5	6	7	8	9	10	11	12	4	5	6	7	8	9	10	11	12
#10 Injector (psi)		3	9	13	19	23	29	34	39	4	9	17	22	28	34	41	47	54
#15 Injector (psi)				2	5	8	12	15	19			4	7	12	16	21	24	29
#20 Injector (psi)						1	4	7	9					4	7	10	13	17
#30 Injector (psi)																	2	4
#40 Injector (psi)																		
GPM (per nozzle)	0.38	0.47	0.57	0.66	0.76	0.85	0.95	1.04	1.14	0.47	0.59	0.71	0.83	0.95	1.06	1.18	1.30	1.42
Flow Indicator 1/2" SS Ball Level	0.8	1.1	1.4	1.7	2.0	2.4	2.7	3.0	3.3	1.1	1.5	1.9	2.3	2.7	3.1	3.5	3.9	4.3
Flow Indicator 7/16" SS Ball Level					0.0	0.3	0.5	0.8	1.0				0.2	0.5	0.8	1.1	1.4	1.8

	30 Gallons Per Acre									35 Gallons Per Acre								
Speed (MPH)	4	5	6	7	8	9	10	11	12	4	5	6	7	8	9	10	11	12
#10 Injector (psi)	9	15	24	30	38	45	54	61	69	14	21	31	39	48	56	66	74	84
#15 Injector (psi)		3	9	13	19	23	29	33	39	3	7	14	19	26	31	37	42	49
#20 Injector (psi)			2	5	9	12	17	20	24			5	9	14	18	23	27	31
#30 Injector (psi)						1	4	6	9					3	5	8	11	14
#40 Injector (psi)									2							1	3	5
GPM (per nozzle)	0.57	0.71	0.85	0.99	1.14	1.28	1.42	1.56	1.70	0.66	0.83	0.99	1.16	1.32	1.49	1.66	1.82	1.99
Flow Indicator 1/2" SS Ball Level	1.4	1.9	2.4	2.8	3.3	3.8	4.3	4.8	5.3	1.7	2.3	2.8	3.4	4.0	4.5	5.1	5.7	6.2
Flow Indicator 7/16" SS Ball Level			0.3	0.6	1.0	1.4	1.8	2.1	2.5		0.2	0.6	1.1	1.5	1.9	2.4	2.8	3.2

**NOTES:**

- The values highlighted in green indicate pressures that are in the optimal pressure range of 20 - 50 psi. The row spacing is 22 inches.
- Density or viscosity of the liquid can effect operating range.
- A displayed pressure higher than the calculated pressure may be due to a pressure drop in the fertilizer hoses.
- With #10 on the center, use #15 for one and a half rate outside, (35 knife).
- With #15 on the center, use #8 for half rate outside, (37 knife), and #20 for one and a half rate outside, (35 knife).
- With #20 on the center, use #10 for half rate outside, (37 knife), and #30 for one and a half rate outside, (35 knife).
- With #30 on the center, use #15 for half rate outside, (37 knife), and #40 for **one and a third** rate outside, (35 knife).
- With #40 on the center, use #20 for half rate outside, (37 knife), and #60 for one and a half rate outside, (35 knife).

For replacement injectors, see "Coulter Injector Assembly" in the Parts Manual.



# Injectors - 22" Row Spacing

Speed (MPH)	40 Gallons Per Acre									45 Gallons Per Acre								
	4	5	6	7	8	9	10	11	12	4	5	6	7	8	9	10	11	12
#10 Injector (psi)	19	27	39	47	57	67	79	88	99	24	33	46	55	67	78	91	102	114
#15 Injector (psi)	6	11	19	25	33	38	45	51	59	9	15	24	30	40	46	53	60	69
#20 Injector (psi)		3	9	13	19	23	29	34	39	1	6	13	18	24	29	35	40	46
#30 Injector (psi)				2	6	9	12	15	19			1	5	9	12	17	20	24
#40 Injector (psi)						1	4	6	9					1	4	7	10	13
GPM (per nozzle)	0.76	0.95	1.14	1.32	1.51	1.70	1.89	2.08	2.27	0.85	1.06	1.28	1.49	1.70	1.92	2.13	2.34	2.55
Flow Indicator 1/2" SS Ball Level	2.0	2.7	3.3	4.0	4.6	5.3	5.9	6.6		2.4	3.1	3.8	4.5	5.3	6.0	6.7		
Flow Indicator 7/16" SS Ball Level		0.5	1.0	1.5	2.0	2.5	3.0	3.5	4.0	0.3	0.8	1.4	1.9	2.5	3.0	3.6	4.2	4.7

Speed (MPH)	50 Gallons Per Acre									55 Gallons Per Acre								
	4	5	6	7	8	9	10	11	12	4	5	6	7	8	9	10	11	12
#10 Injector (psi)	29	39	54	64	77	89	104	115	129	34	45	61	72	87	100	116	129	144
#15 Injector (psi)	13	19	29	36	46	53	61	69	79	16	23	34	42	53	61	70	78	89
#20 Injector (psi)	4	9	17	22	29	34	41	47	54	6	12	20	26	34	40	48	54	61
#30 Injector (psi)			4	8	13	16	21	25	29		1	6	10	16	20	25	29	34
#40 Injector (psi)					4	7	10	13	17				3	6	9	13	16	20
GPM (per nozzle)	0.95	1.18	1.42	1.66	1.89	2.13	2.36	2.60	2.84	1.04	1.30	1.56	1.82	2.08	2.34	2.60	2.86	3.12
Flow Indicator 1/2" SS Ball Level	2.7	3.5	4.3	5.1	5.9	6.7				3.0	3.9	4.8	5.7	6.6				
Flow Indicator 7/16" SS Ball Level	0.5	1.1	1.8	2.4	3.0	3.6	4.2	4.8	5.5	0.8	1.4	2.1	2.8	3.5	4.2	4.8	5.5	6.2

Speed (MPH)	60 Gallons Per Acre									65 Gallons Per Acre								
	4	5	6	7	8	9	10	11	12	4	5	6	7	8	9	10	11	12
#10 Injector (psi)	39	51	68	80	96	110	129	143	159	44	57	76	89	106	121	141	156	174
#15 Injector (psi)	19	27	39	48	60	68	78	87	99	23	31	44	53	67	76	86	96	109
#20 Injector (psi)	9	15	24	30	39	45	54	60	68	11	18	28	35	44	51	60	67	76
#30 Injector (psi)		3	9	13	19	24	29	34	39	1	5	11	16	23	27	34	38	44
#40 Injector (psi)			2	5	9	12	16	20	24			4	7	11	15	20	23	28
GPM (per nozzle)	1.14	1.42	1.70	1.99	2.27	2.55	2.84	3.12	3.41	1.23	1.54	1.84	2.15	2.46	2.77	3.07	3.38	3.69
Flow Indicator 1/2" SS Ball Level	3.3	4.3	5.3	6.2						3.7	4.7	5.7	6.8					
Flow Indicator 7/16" SS Ball Level	1.0	1.8	2.5	3.2	4.0	4.7	5.5	6.2	6.9	1.3	2.1	2.9	3.7	4.5	5.3	6.1	6.9	

Speed (MPH)	70 Gallons Per Acre									75 Gallons Per Acre								
	4	5	6	7	8	9	10	11	12	4	5	6	7	8	9	10	11	12
#10 Injector (psi)	49	63	83	97	116	132	154	170	189	54	68	91	106	125	143	166	183	204
#15 Injector (psi)	26	35	49	59	74	83	94	105	119	29	39	54	65	81	91	102	114	129
#20 Injector (psi)	14	21	32	39	49	56	66	74	83	16	24	35	43	54	62	72	81	91
#30 Injector (psi)	3	7	14	19	26	31	38	43	49	4	9	16	22	29	35	42	47	54
#40 Injector (psi)			5	9	14	18	23	27	32		2	7	11	16	21	26	30	35
GPM (per nozzle)	1.32	1.66	1.99	2.32	2.65	2.98	3.31	3.64	3.97	1.42	1.77	2.13	2.48	2.84	3.19	3.55	3.90	4.26
Flow Indicator 1/2" SS Ball Level	4.0	5.1	6.2							4.3	5.5	6.7						
Flow Indicator 7/16" SS Ball Level	1.5	2.4	3.2	4.1	5.0	5.8	6.7			1.8	2.7	3.6	4.5	5.5	6.4			

NOTE - The values highlighted in green indicate pressures that are in the optimal pressure range of 20 - 50 psi. The row spacing is 22 inches.



# Injectors - 30" Row Spacing

	15 Gallons Per Acre								
Speed (MPH)	4	5	6	7	8	9	10	11	12
#10 Injector (psi)		4	10	14	20	24	30	35	40
#15 Injector (psi)				2	6	9	13	16	20
#20 Injector (psi)						2	5	7	10
#30 Injector (psi)									
#40 Injector (psi)									
GPM (per nozzle)	0.34	0.43	0.51	0.60	0.68	0.77	0.86	0.94	1.03
Flow Indicator Red Glass Ball Level	1.9	2.7	3.4	4.1	4.9	5.6	6.4		
Flow Indicator 1/2" SS Ball Level	0.6	0.9	1.2	1.5	1.8	2.1	2.4	2.7	3.0
Flow Indicator 7/16" SS Ball Level						0.1	0.3	0.5	0.7

	20 Gallons Per Acre									25 Gallons Per Acre								
Speed (MPH)	4	5	6	7	8	9	10	11	12	4	5	6	7	8	9	10	11	12
#10 Injector (psi)	6	12	20	26	33	39	47	53	61	13	20	30	37	46	54	64	72	81
#15 Injector (psi)		1	6	10	15	19	24	29	34	2	6	13	18	25	30	35	41	47
#20 Injector (psi)				2	6	9	13	16	20			5	8	13	17	22	26	30
#30 Injector (psi)							1	4	6					2	4	7	10	13
#40 Injector (psi)																	2	5
GPM (per nozzle)	0.52	0.64	0.77	0.90	1.03	1.16	1.29	1.42	1.55	0.64	0.81	0.97	1.13	1.29	1.45	1.61	1.77	1.93
Flow Indicator 1/2" SS Ball Level	1.2	1.7	2.1	2.5	3.0	3.4	3.9	4.3	4.7	1.7	2.2	2.8	3.3	3.9	4.4	5.0	5.5	6.1
Flow Indicator 7/16" SS Ball Level			0.1	0.4	0.7	1.1	1.4	1.8	2.1		0.2	0.6	1.0	1.4	1.8	2.3	2.7	3.1

	30 Gallons Per Acre									35 Gallons Per Acre								
Speed (MPH)	4	5	6	7	8	9	10	11	12	4	5	6	7	8	9	10	11	12
#10 Injector (psi)	20	28	40	48	59	69	81	90	102	27	36	50	60	72	84	98	109	122
#15 Injector (psi)	7	12	20	26	36	40	47	53	61	11	17	27	34	43	50	58	65	75
#20 Injector (psi)		3	10	14	20	24	30	35	40	3	8	15	20	27	32	39	44	50
#30 Injector (psi)				2	7	9	13	16	20			3	6	11	15	19	22	27
#40 Injector (psi)						2	4	7	10					3	5	9	11	15
GPM (per nozzle)	0.77	0.97	1.16	1.35	1.55	1.74	1.93	2.13	2.32	0.90	1.13	1.35	1.58	1.81	2.03	2.26	2.48	2.71
Flow Indicator 1/2" SS Ball Level	2.1	2.8	3.4	4.1	4.7	5.4	6.1	6.7		2.5	3.3	4.1	4.8	5.6	6.4			
Flow Indicator 7/16" SS Ball Level	0.1	0.6	1.1	1.6	2.1	2.6	3.1	3.6	4.1	0.4	1.0	1.6	2.2	2.8	3.4	3.9	4.5	5.1

**NOTES:**

- The values highlighted in green indicate pressures that are in the optimal pressure range of 20 - 50 psi. The row spacing is 30 inches.
- Density or viscosity of the liquid can effect operating range.
- A displayed pressure higher than the calculated pressure may be due to a pressure drop in the fertilizer hoses.
- With #10 on the center, use #15 for one and a half rate outside, (23 knife).
- With #15 on the center, use #8 for half rate outside, (25 knife), and #20 for one and a half rate outside, (23 knife).
- With #20 on the center, use #10 for half rate outside, (25 knife), and #30 for one and a half rate outside, (23 knife).
- With #30 on the center, use #15 for half rate outside, (25 knife), and #40 for **one and a third** rate outside, (23 knife).
- With #40 on the center, use #20 for half rate outside, (25 knife), and #60 for one and a half rate outside, (23 knife).

For replacement injectors, see "Coulter Injector Assembly" in the Parts Manual.





# Injectors - 30" Row Spacing

Speed (MPH)	40 Gallons Per Acre										45 Gallons Per Acre							
	4	5	6	7	8	9	10	11	12	4	5	6	7	8	9	10	11	12
#10 Injector (psi)	33	44	60	71	86	99	115	128	143	40	52	70	83	99	113	132	146	163
#15 Injector (psi)	16	23	33	41	53	60	69	78	88	20	28	40	49	62	70	80	90	102
#20 Injector (psi)	6	12	20	26	33	39	47	53	60	10	16	25	32	40	47	55	62	70
#30 Injector (psi)		1	6	10	16	20	25	29	33		4	10	14	20	25	31	35	40
#40 Injector (psi)				2	6	9	13	16	20			2	5	10	13	17	21	25
GPM (per nozzle)	1.03	1.29	1.55	1.81	2.06	2.32	2.58	2.84	3.10	1.16	1.45	1.74	2.03	2.32	2.61	2.90	3.19	3.48
Flow Indicator 1/2" SS Ball Level	3.0	3.9	4.7	5.6	6.5					3.4	4.4	5.4	6.4					
Flow Indicator 7/16" SS Ball Level	0.7	1.4	2.1	2.8	3.4	4.1	4.8	5.5	6.1	1.1	1.8	2.6	3.4	4.1	4.9	5.6	6.4	

Speed (MPH)	50 Gallons Per Acre										55 Gallons Per Acre							
	4	5	6	7	8	9	10	11	12	4	5	6	7	8	9	10	11	12
#10 Injector (psi)	47	60	80	94	112	128	149	165	184	54	68	91	106	125	143	166	183	204
#15 Injector (psi)	25	34	47	57	71	80	91	102	115	29	39	54	65	81	91	102	114	129
#20 Injector (psi)	13	20	30	37	47	54	64	71	80	16	24	35	43	54	62	72	81	91
#30 Injector (psi)	2	6	13	18	25	30	36	41	47	4	9	16	22	29	35	42	47	54
#40 Injector (psi)			5	8	13	17	22	26	30		2	7	11	16	21	26	30	35
GPM (per nozzle)	1.29	1.61	1.93	2.26	2.58	2.90	3.22	3.55	3.87	1.42	1.77	2.13	2.48	2.84	3.19	3.55	3.90	4.26
Flow Indicator 1/2" SS Ball Level	3.9	5.0	6.1							4.3	5.5	6.7						
Flow Indicator 7/16" SS Ball Level	1.4	2.3	3.1	3.9	4.8	5.6	6.5			1.8	2.7	3.6	4.5	5.5	6.4			

Speed (MPH)	60 Gallons Per Acre										65 Gallons Per Acre							
	4	5	6	7	8	9	10	11	12	4	5	6	7	8	9	10	11	12
#10 Injector (psi)	60	77	101	117	138	158	183	202	224	67	85	111	128	152	173	200	221	245
#15 Injector (psi)	34	45	60	73	90	101	113	127	142	38	50	67	81	100	111	124	139	156
#20 Injector (psi)	20	28	40	49	60	69	81	90	101	23	32	46	55	67	77	89	99	111
#30 Injector (psi)	7	12	20	26	34	40	48	54	60	9	15	23	30	38	45	54	60	67
#40 Injector (psi)		4	10	14	20	24	30	35	40		6	12	17	23	28	34	40	46
GPM (per nozzle)	1.55	1.93	2.32	2.71	3.10	3.48	3.87	4.26	4.64	1.68	2.10	2.52	2.93	3.35	3.77	4.19	4.61	5.03
Flow Indicator 1/2" SS Ball Level	4.7	6.1																
Flow Indicator 7/16" SS Ball Level	2.1	3.1	4.1	5.1	6.1					2.4	3.5	4.6	5.7	6.8				

Speed (MPH)	70 Gallons Per Acre										75 Gallons Per Acre							
	4	5	6	7	8	9	10	11	12	4	5	6	7	8	9	10	11	12
#10 Injector (psi)	74	93	121	140	165	188	217	239	265	81	101	131	151	178	203	234	258	286
#15 Injector (psi)	43	55	74	89	109	121	136	151	170	48	61	81	96	118	131	147	163	183
#20 Injector (psi)	27	36	51	61	74	84	98	108	121	30	40	56	67	81	92	106	117	131
#30 Injector (psi)	11	17	27	34	43	50	60	66	74	13	20	30	38	48	55	66	73	81
#40 Injector (psi)	3	8	15	20	27	32	39	44	51	5	10	18	23	30	36	43	49	56
GPM (per nozzle)	1.81	2.26	2.71	3.16	3.61	4.06	4.51	4.97	5.42	1.93	2.42	2.90	3.39	3.87	4.35	4.84	5.32	5.80
Flow Indicator 7/16" SS Ball Level	2.8	3.9	5.1	6.3						3.1	4.4	5.6	6.9					

NOTE - The values highlighted in green indicate pressures that are in the optimal pressure range of 20 - 50 psi. The row spacing is 30 inches.

# Knife - 20" Row Spacing

Speed (MPH)	10 Gallons Per Acre									15 Gallons Per Acre								
	4	5	6	7	8	9	10	11	12	4	5	6	7	8	9	10	11	12
0.075 Orifice Pressure (psi)				3	6	10	13	17	20		5	10	15	20	25	31	36	41
0.107 Orifice Pressure (psi)																2	4	7
0.132 Orifice Pressure (psi)																		
0.161 Orifice Pressure (psi)																		
GPM (per nozzle)	0.15	0.19	0.23	0.27	0.30	0.34	0.38	0.42	0.46	0.23	0.29	0.34	0.40	0.46	0.51	0.57	0.63	0.68
Flow Indicator Red Glass Ball Level	0.3	0.6	0.9	1.3	1.6	1.9	2.2	2.6	2.9	0.9	1.4	1.9	2.4	2.9	3.4	3.9	4.4	4.9
Flow Indicator 1/2" SS Level		0.1	0.2	0.4	0.5	0.6	0.8	0.9	1.0	0.2	0.4	0.6	0.8	1.0	1.2	1.4	1.6	1.8

Speed (MPH)	20 Gallons Per Acre									25 Gallons Per Acre								
	4	5	6	7	8	9	10	11	12	4	5	6	7	8	9	10	11	12
0.075 Orifice Pressure (psi)	6	13	20	27	34	41	48	55	62	13	22	31	39	48	57	65	74	82
0.107 Orifice Pressure (psi)					4	7	10	14	17				6	10	15	19	23	27
0.132 Orifice Pressure (psi)								5							3	6	9	12
0.161 Orifice Pressure (psi)																		
GPM (per nozzle)	0.30	0.38	0.46	0.53	0.61	0.68	0.76	0.84	0.91	0.38	0.48	0.57	0.67	0.76	0.86	0.95	1.05	1.14
Flow Indicator Red Glass Ball Level	1.6	2.2	2.9	3.6	4.2	4.9	5.5	6.2	6.9	2.2	3.1	3.9	4.7	5.5	6.4			
Flow Indicator 1/2" SS Ball Level	0.5	0.8	1.0	1.3	1.5	1.8	2.1	2.3	2.6	0.8	1.1	1.4	1.7	2.1	2.4	2.7	3.0	3.3
Flow Indicator 7/16" SS Ball Level								0.2	0.4						0.3	0.5	0.8	1.0

Speed (MPH)	30 Gallons Per Acre									35 Gallons Per Acre								
	4	5	6	7	8	9	10	11	12	4	5	6	7	8	9	10	11	12
0.075 Orifice Pressure (psi)	20	31	41	51	62	72	82	93	103	27	39	51	63	76	88	100	112	124
0.107 Orifice Pressure (psi)		2	7	12	17	22	27	32	37		6	12	18	24	30	36	42	48
0.132 Orifice Pressure (psi)					5	8	12	15	18				6	9	13	17	21	25
0.161 Orifice Pressure (psi)								3	5							5	7	10
GPM (per nozzle)	0.46	0.57	0.68	0.80	0.91	1.03	1.14	1.26	1.37	0.53	0.67	0.80	0.93	1.07	1.20	1.33	1.46	1.60
Flow Indicator Red Glass Ball Level	2.9	3.9	4.9	5.9	6.9													
Flow Indicator 1/2" SS Ball Level	1.0	1.4	1.8	2.2	2.6	3.0	3.3	3.7	4.1	1.3	1.7	2.2	2.6	3.1	3.5	4.0	4.5	4.9
Flow Indicator 7/16" SS Ball Level				0.1	0.4	0.7	1.0	1.3	1.6			0.1	0.5	0.8	1.2	1.5	1.9	2.2

**NOTES:**

- Values highlighted in green indicate pressures that are within the optimal range of 20 - 50 psi. The row spacing is 20 inches.
- Density or viscosity of the liquid can effect operating range.
- A displayed pressure higher than the calculated pressure may be due to a pressure drop in the fertilizer hoses.
- With .075 on the center, use .054 for half rate outside (37 knife) and .093 for one and a half rate outside (35 knife).
- With .107 on the center, use .075 for half rate outside (37 knife) and .132 for one and a half rate outside (35 knife).
- With .132 on the center, use .093 for half rate outside (37 knife) and .161 for one and a half rate outside (35 knife).
- With .161 on the center, use .107 for half rate outside (37 knife) and .196 for one and a half rate outside (35 knife).

For replacement orifices, see "Check Valve" in the Parts Manual.

<i>Kit</i>	<b>0.075</b>	<b>0.093</b>	<b>0.107</b>	<b>0.132</b>	<b>0.161</b>	<b>0.196</b>
<i>35 Knife</i>	0	0	33	33	33	2
<i>37 Knife</i>	2	2	35	35	35	0



# Knife - 20" Row Spacing

Speed (MPH)	40 Gallons Per Acre										45 Gallons Per Acre									
	4	5	6	7	8	9	10	11	12	4	5	6	7	8	9	10	11	12		
0.075 Orifice Pressure (psi)	34	48	62	76	89	103	117	131	145	41	57	72	88	103	119	134	150	165		
0.107 Orifice Pressure (psi)	4	10	17	24	31	37	44	51	58	7	15	22	30	37	45	53	60	68		
0.132 Orifice Pressure (psi)			5	9	14	18	23	27	31		3	8	13	18	23	28	33	38		
0.161 Orifice Pressure (psi)						5	8	11	14					5	9	12	15	18		
GPM (per nozzle)	0.61	0.76	0.91	1.07	1.22	1.37	1.52	1.67	1.83	0.68	0.86	1.03	1.20	1.37	1.54	1.71	1.88	2.05		
Flow Indicator 1/2" SS Ball Level	1.5	2.1	2.6	3.1	3.6	4.1	4.6	5.2	5.7	1.8	2.4	3.0	3.5	4.1	4.7	5.3	5.9	6.5		
Flow Indicator 7/16" SS Ball Level			0.4	0.8	1.2	1.6	2.0	2.4	2.8		0.3	0.7	1.2	1.6	2.1	2.5	3.0	3.4		

Speed (MPH)	50 Gallons Per Acre										55 Gallons Per Acre									
	4	5	6	7	8	9	10	11	12	4	5	6	7	8	9	10	11	12		
0.075 Orifice Pressure (psi)	48	65	82	100	117	134	152	169	186	55	74	93	112	131	150	169	188	207		
0.107 Orifice Pressure (psi)	10	19	27	36	44	53	61	70	78	14	23	32	42	51	60	70	79	88		
0.132 Orifice Pressure (psi)		6	12	17	23	28	33	39	44		9	15	21	27	33	39	45	51		
0.161 Orifice Pressure (psi)				5	8	12	16	19	23			3	7	11	15	19	23	27		
GPM (per nozzle)	0.76	0.95	1.14	1.33	1.52	1.71	1.90	2.09	2.28	0.84	1.05	1.26	1.46	1.67	1.88	2.09	2.30	2.51		
Flow Indicator 1/2" SS Ball Level	2.1	2.7	3.3	4.0	4.6	5.3	5.9	6.6		2.3	3.0	3.7	4.5	5.2	5.9	6.6				
Flow Indicator 7/16" SS Ball Level	0.0	0.5	1.0	1.5	2.0	2.5	3.0	3.5	4.0	0.2	0.8	1.3	1.9	2.4	3.0	3.5	4.1	4.6		

Speed (MPH)	60 Gallons Per Acre										65 Gallons Per Acre									
	4	5	6	7	8	9	10	11	12	4	5	6	7	8	9	10	11	12		
0.075 Orifice Pressure (psi)	62	82	103	124	145	165	186	207	228	69	91	114	136	158	181	203	226	248		
0.107 Orifice Pressure (psi)	17	27	37	48	58	68	78	88	99	21	32	43	54	65	76	87	98	109		
0.132 Orifice Pressure (psi)	5	12	18	25	31	38	44	51	58	7	14	21	29	36	43	50	57	64		
0.161 Orifice Pressure (psi)			5	10	14	18	23	27	32			7	12	17	22	27	31	36		
GPM (per nozzle)	0.91	1.14	1.37	1.60	1.83	2.05	2.28	2.51	2.74	0.99	1.24	1.48	1.73	1.98	2.23	2.47	2.72	2.97		
Flow Indicator 1/2" SS Ball Level	2.6	3.3	4.1	4.9	5.7	6.5				2.8	3.7	4.5	5.4	6.2						
Flow Indicator 7/16" SS Ball Level	0.4	1.0	1.6	2.2	2.8	3.4	4.0	4.6	5.2	0.6	1.3	1.9	2.6	3.2	3.9	4.5	5.1	5.8		

Speed (MPH)	70 Gallons Per Acre										75 Gallons Per Acre									
	4	5	6	7	8	9	10	11	12	4	5	6	7	8	9	10	11	12		
0.075 Orifice Pressure (psi)	76	100	124	148	172	196	221	245	269	82	108	134	160	186	212	238	264	290		
0.107 Orifice Pressure (psi)	24	36	48	60	71	83	95	107	119	27	40	53	66	78	91	104	116	129		
0.132 Orifice Pressure (psi)	9	17	25	32	40	48	55	63	71	12	20	28	36	44	53	61	69	77		
0.161 Orifice Pressure (psi)		5	10	15	20	25	30	35	40		6	12	17	23	28	34	39	45		
GPM (per nozzle)	1.07	1.33	1.60	1.86	2.13	2.40	2.66	2.93	3.20	1.14	1.43	1.71	2.00	2.28	2.57	2.85	3.14	3.42		
Flow Indicator 1/2" SS Ball Level	3.1	4.0	4.9	5.8	6.7					3.3	4.3	5.3	5.3	6.3						
Flow Indicator 7/16" SS Ball Level	0.8	1.5	2.2	2.9	3.6	4.3	5.0	5.7	6.4	1.0	1.8	2.5	3.3	4.0	4.7	5.5	6.2	7.0		

NOTE - The values highlighted in green indicate pressures that are in the optimal pressure range of 20 - 50 psi. The row spacing is 20 inches.

# Knife - 22" Row Spacing

Speed (MPH)	10 Gallons Per Acre									15 Gallons Per Acre								
	4	5	6	7	8	9	10	11	12	4	5	6	7	8	9	10	11	12
0.075 Orifice Pressure (psi)			2	5	9	13	17	21	24	2	7	13	19	24	30	36	41	47
0.107 Orifice Pressure (psi)															2	4	7	10
0.132 Orifice Pressure (psi)																		
0.161 Orifice Pressure (psi)																		
GPM (per nozzle)	0.17	0.21	0.25	0.29	0.33	0.38	0.42	0.46	0.50	0.25	0.31	0.38	0.44	0.50	0.57	0.63	0.69	0.75
Flow Indicator Red Glass Ball Level	0.4	0.8	1.1	1.5	1.8	2.2	2.6	2.9	3.3	1.1	1.7	2.2	2.8	3.3	3.8	4.4	4.9	5.5
Flow Indicator 1/2" SS Level		0.2	0.3	0.5	0.6	0.7	0.9	1.0	1.2	0.3	0.5	0.7	1.0	1.2	1.4	1.6	1.8	2.0

Speed (MPH)	20 Gallons Per Acre									25 Gallons Per Acre								
	4	5	6	7	8	9	10	11	12	4	5	6	7	8	9	10	11	12
0.075 Orifice Pressure (psi)	9	17	24	32	40	47	55	62	70	17	26	36	45	55	64	74	83	93
0.107 Orifice Pressure (psi)					6	10	14	17	21			4	9	14	18	23	28	32
0.132 Orifice Pressure (psi)								5	8					3	6	9	12	15
0.161 Orifice Pressure (psi)																		3
GPM (per nozzle)	0.33	0.42	0.50	0.59	0.67	0.75	0.84	0.92	1.00	0.42	0.52	0.63	0.73	0.84	0.94	1.05	1.15	1.26
Flow Indicator Red Glass Ball Level	1.8	2.6	3.3	4.0	4.8	5.5	6.2	6.9	7.7	2.6	3.5	4.4	5.3	6.2				
Flow Indicator 1/2" SS Ball Level	0.6	0.9	1.2	1.5	1.7	2.0	2.3	2.6	2.9	0.9	1.2	1.6	2.0	2.3	2.7	3.0	3.4	3.7
Flow Indicator 7/16" SS Ball Level							0.2	0.5	0.7					0.2	0.5	0.8	1.1	1.3

Speed (MPH)	30 Gallons Per Acre									35 Gallons Per Acre								
	4	5	6	7	8	9	10	11	12	4	5	6	7	8	9	10	11	12
0.075 Orifice Pressure (psi)	24	36	47	59	70	81	93	104	116	32	45	59	72	85	98	112	125	138
0.107 Orifice Pressure (psi)		4	10	16	21	27	32	38	44		9	16	22	29	35	42	48	55
0.132 Orifice Pressure (psi)				4	8	11	15	18	22			4	8	12	17	21	25	29
0.161 Orifice Pressure (psi)							3	5	8						4	7	10	13
GPM (per nozzle)	0.50	0.63	0.75	0.88	1.00	1.13	1.26	1.38	1.51	0.59	0.73	0.88	1.03	1.17	1.32	1.46	1.61	1.76
Flow Indicator Red Glass Ball Level	3.3	4.4	5.5	6.6														
Flow Indicator 1/2" SS Ball Level	1.2	1.6	2.0	2.5	2.9	3.3	3.7	4.2	4.6	1.5	2.0	2.5	3.0	3.5	4.0	4.5	5.0	5.4
Flow Indicator 7/16" SS Ball Level				0.3	0.7	1.0	1.3	1.7	2.0			0.3	0.7	1.1	1.5	1.9	2.3	2.6

**NOTES:**

- Values highlighted in green indicate pressures that are within the optimal range of 20 - 50 psi. The row spacing is 22 inches.
- Density or viscosity of the liquid can effect operating range.
- A displayed pressure higher than the calculated pressure may be due to a pressure drop in the fertilizer hoses.
- With .075 on the center, use .054 for half rate outside (37 knife) and .093 for one and a half rate outside (35 knife).
- With .107 on the center, use .075 for half rate outside (37 knife) and .132 for one and a half rate outside (35 knife).
- With .132 on the center, use .093 for half rate outside (37 knife) and .161 for one and a half rate outside (35 knife).
- With .161 on the center, use .107 for half rate outside (37 knife) and .196 for one and a half rate outside (35 knife).

For replacement orifices, see "Check Valve" in the Parts Manual.

<b>Kit</b>						
	<b>0.075</b>	<b>0.093</b>	<b>0.107</b>	<b>0.132</b>	<b>0.161</b>	<b>0.196</b>
35 Knife	0	0	33	33	33	2
37 Knife	2	2	35	35	35	0



# Knife - 22" Row Spacing

Speed (MPH)	40 Gallons Per Acre									45 Gallons Per Acre								
	4	5	6	7	8	9	10	11	12	4	5	6	7	8	9	10	11	12
0.075 Orifice Pressure (psi)	40	55	70	85	100	116	131	146	161	47	64	81	98	116	133	150	167	184
0.107 Orifice Pressure (psi)	6	14	21	29	36	44	51	59	66	10	18	27	35	44	52	60	69	77
0.132 Orifice Pressure (psi)			8	12	17	22	27	32	37		6	11	17	22	28	33	38	44
0.161 Orifice Pressure (psi)					5	8	11	14	18				4	8	12	15	19	22
GPM (per nozzle)	0.67	0.84	1.00	1.17	1.34	1.51	1.67	1.84	2.01	0.75	0.94	1.13	1.32	1.51	1.70	1.88	2.07	2.26
Flow Indicator 1/2" SS Ball Level	1.7	2.3	2.9	3.5	4.0	4.6	5.2	5.7	6.3	2.0	2.7	3.3	4.0	4.6	5.2	5.9	6.5	
Flow Indicator 7/16" SS Ball Level		0.2	0.7	1.1	1.5	2.0	2.4	2.9	3.3		0.5	1.0	1.5	2.0	2.5	3.0	3.5	3.9

Speed (MPH)	50 Gallons Per Acre									55 Gallons Per Acre								
	4	5	6	7	8	9	10	11	12	4	5	6	7	8	9	10	11	12
0.075 Orifice Pressure (psi)	55	74	93	112	131	150	169	188	207	62	83	104	125	146	167	188	209	230
0.107 Orifice Pressure (psi)	14	23	32	42	51	60	70	79	88	17	28	38	48	59	69	79	89	100
0.132 Orifice Pressure (psi)		9	15	21	27	33	39	45	51	5	12	18	25	32	38	45	52	58
0.161 Orifice Pressure (psi)			3	7	11	15	19	23	27			5	10	14	19	23	28	32
GPM (per nozzle)	0.84	1.05	1.26	1.46	1.67	1.88	2.09	2.30	2.51	0.92	1.15	1.38	1.61	1.84	2.07	2.30	2.53	2.76
Flow Indicator 1/2" SS Ball Level	2.3	3.0	3.7	4.5	5.2	5.9	6.6			2.6	3.4	4.2	5.0	5.7	6.5			
Flow Indicator 7/16" SS Ball Level	0.2	0.8	1.3	1.9	2.4	3.0	3.5	4.1	4.6	0.5	1.1	1.7	2.3	2.9	3.5	4.1	4.7	5.3

Speed (MPH)	60 Gallons Per Acre									65 Gallons Per Acre								
	4	5	6	7	8	9	10	11	12	4	5	6	7	8	9	10	11	12
0.075 Orifice Pressure (psi)	70	93	116	138	161	184	207	230	252	78	102	127	152	176	201	226	250	275
0.107 Orifice Pressure (psi)	21	32	44	55	66	77	88	100	111	25	37	49	61	73	86	98	110	122
0.132 Orifice Pressure (psi)	8	15	22	29	37	44	51	58	66	10	18	26	34	41	49	57	65	73
0.161 Orifice Pressure (psi)		3	8	13	18	22	27	32	37		5	10	16	21	26	31	37	42
GPM (per nozzle)	1.00	1.26	1.51	1.76	2.01	2.26	2.51	2.76	3.01	1.09	1.36	1.63	1.90	2.18	2.45	2.72	2.99	3.26
Flow Indicator 1/2" SS Ball Level	2.9	3.7	4.6	5.4	6.3					3.2	4.1	5.0	5.9	6.9				
Flow Indicator 7/16" SS Ball Level	0.7	1.3	2.0	2.6	3.3	3.9	4.6	5.3	5.9	0.9	1.6	2.3	3.0	3.7	4.4	5.1	5.9	6.6

Speed (MPH)	70 Gallons Per Acre									75 Gallons Per Acre								
	4	5	6	7	8	9	10	11	12	4	5	6	7	8	9	10	11	12
0.075 Orifice Pressure (psi)	85	112	138	165	192	218	245	271	298	93	121	150	178	207	235	264	292	321
0.107 Orifice Pressure (psi)	29	42	55	68	81	94	107	120	133	32	46	60	74	88	102	116	130	144
0.132 Orifice Pressure (psi)	12	21	29	38	46	55	63	72	80	15	24	33	42	51	60	69	78	87
0.161 Orifice Pressure (psi)		7	13	18	24	30	35	41	47	3	9	15	21	27	33	39	45	51
GPM (per nozzle)	1.17	1.46	1.76	2.05	2.34	2.64	2.93	3.22	3.52	1.26	1.57	1.88	2.20	2.51	2.83	3.14	3.45	3.77
Flow Indicator 1/2" SS Ball Level	3.5	4.5	5.4	6.4						3.7	4.8	5.9	6.9					
Flow Indicator 7/16" SS Ball Level	1.1	1.9	2.6	3.4	4.2	4.9	5.7	6.5		1.3	2.1	3.0	3.8	4.6	5.4	6.2		

NOTE - The values highlighted in green indicate pressures that are in the optimal pressure range of 20 - 50 psi. The row spacing is 22 inches.

# Knife - 30" Row Spacing

Speed (MPH)	10 Gallons Per Acre										15 Gallons Per Acre							
	4	5	6	7	8	9	10	11	12	4	5	6	7	8	9	10	11	12
0.075 Orifice Pressure (psi)		5	10	15	20	25	31	36	41	10	18	25	33	41	49	57	64	72
0.107 Orifice Pressure (psi)							2	4	7				3	7	11	15	18	22
0.132 Orifice Pressure (psi)															1	3	6	8
0.161 Orifice Pressure (psi)																		
GPM (per nozzle)	0.23	0.29	0.34	0.40	0.46	0.51	0.57	0.63	0.68	0.34	0.43	0.51	0.60	0.68	0.77	0.86	0.94	1.03
Flow Indicator Red Glass Ball Level	0.9	1.4	1.9	2.4	2.9	3.4	3.9	4.4	4.9	1.9	2.7	3.4	4.1	4.9	5.6	6.4		
Flow Indicator 1/2" SS Ball Level	0.2	0.4	0.6	0.8	1.0	1.2	1.4	1.6	1.8	0.6	0.9	1.2	1.5	1.8	2.1	2.4	2.7	3.0
Flow Indicator 7/16" SS Ball Level															0.1	0.3	0.5	0.7

Speed (MPH)	20 Gallons Per Acre										25 Gallons Per Acre							
	4	5	6	7	8	9	10	11	12	4	5	6	7	8	9	10	11	12
0.075 Orifice Pressure (psi)	20	31	41	51	62	72	82	93	103	31	44	57	69	82	95	108	121	134
0.107 Orifice Pressure (psi)			7	12	17	22	27	32	37		8	15	21	27	34	40	46	53
0.132 Orifice Pressure (psi)					5	8	12	15	18			3	7	12	16	20	24	28
0.161 Orifice Pressure (psi)								3	5						4	6	9	12
GPM (per nozzle)	0.46	0.57	0.68	0.80	0.91	1.03	1.14	1.26	1.37	0.57	0.71	0.86	1.00	1.14	1.28	1.43	1.57	1.71
Flow Indicator Red Glass Ball Level	2.9	3.9	4.9	5.9	6.9					3.9	5.1	6.4						
Flow Indicator 1/2" SS Ball Level	1.0	1.4	1.8	2.2	2.6	3.0	3.3	3.7	4.1	1.4	1.9	2.4	2.9	3.3	3.8	4.3	4.8	5.3
Flow Indicator 7/16" SS Ball Level				0.1	0.4	0.7	1.0	1.3	1.6			0.3	0.7	1.0	1.4	1.8	2.1	2.5

Speed (MPH)	30 Gallons Per Acre										35 Gallons Per Acre							
	4	5	6	7	8	9	10	11	12	4	5	6	7	8	9	10	11	12
0.075 Orifice Pressure (psi)	41	57	72	88	103	119	134	150	165	51	69	88	106	124	142	160	178	196
0.107 Orifice Pressure (psi)	7	15	22	30	37	45	53	60	68	12	21	30	39	48	57	66	74	83
0.132 Orifice Pressure (psi)		3	8	13	18	23	28	33	38		7	13	19	25	30	36	42	48
0.161 Orifice Pressure (psi)					5	9	12	15	18				6	10	13	17	21	25
GPM (per nozzle)	0.68	0.86	1.03	1.20	1.37	1.54	1.71	1.88	2.05	0.80	1.00	1.20	1.40	1.60	1.80	2.00	2.20	2.40
Flow Indicator Red Glass Ball Level	4.9	6.4																
Flow Indicator 1/2" SS Ball Level	1.8	2.4	3.0	3.5	4.1	4.7	5.3	5.9	6.5	2.2	2.9	3.5	4.2	4.9	5.6	6.3	6.9	
Flow Indicator 7/16" SS Ball Level		0.3	0.7	1.2	1.6	2.1	2.5	3.0	3.4	0.1	0.7	1.2	1.7	2.2	2.7	3.3	3.8	4.3

- NOTES:
- Values highlighted in green indicate pressures that are within the optimal range of 20 - 50 psi. The row spacing is 30 inches.
  - Density or viscosity of the liquid can effect operating range.
  - A displayed pressure higher than the calculated pressure may be due to a pressure drop in the fertilizer hoses.
  - With .075 on the center, use .054 for half rate outside (25 knife) and .093 for one and a half rate outside (23 knife).
  - With .107 on the center, use .075 for half rate outside (25 knife) and .132 for one and a half rate outside (23 knife).
  - With .132 on the center, use .093 for half rate outside (25 knife) and .161 for one and a half rate outside (23 knife).
  - With .161 on the center, use .107 for half rate outside (25 knife) and .196 for one and a half rate outside (23 knife).

For replacement orifices, see "Check Valve" in the Parts Manual.

Kit	0.075	0.093	0.107	0.132	0.161	0.196
23 Knife	0	0	21	21	21	2
25 Knife	2	2	23	23	23	0





# Knife - 30" Row Spacing

Speed (MPH)	40 Gallons Per Acre										45 Gallons Per Acre							
	4	5	6	7	8	9	10	11	12	4	5	6	7	8	9	10	11	12
0.075 Orifice Pressure (psi)	62	82	103	124	145	165	186	207	228	72	95	119	142	165	189	212	235	259
0.107 Orifice Pressure (psi)	17	27	37	48	58	68	78	88	99	22	34	45	57	68	80	91	102	114
0.132 Orifice Pressure (psi)	5	12	18	25	31	38	44	51	58	8	16	23	30	38	45	53	60	67
0.161 Orifice Pressure (psi)			5	10	14	18	23	27	32		4	9	13	18	23	28	33	38
GPM (per nozzle)	0.91	1.14	1.37	1.60	1.83	2.05	2.28	2.51	2.74	1.03	1.28	1.54	1.80	2.05	2.31	2.57	2.83	3.08
Flow Indicator 1/2" SS Ball Level	2.6	3.3	4.1	4.9	5.7	6.5				3.0	3.8	4.7	5.6	6.5				
Flow Indicator 7/16" SS Ball Level	0.4	1.0	1.6	2.2	2.8	3.4	4.0	4.6	5.2	0.7	1.4	2.1	2.7	3.4	4.1	4.7	5.4	6.1

Speed (MPH)	50 Gallons Per Acre										55 Gallons Per Acre							
	4	5	6	7	8	9	10	11	12	4	5	6	7	8	9	10	11	12
0.075 Orifice Pressure (psi)	82	108	134	160	186	212	238	264	290	93	121	150	178	207	235	264	292	321
0.107 Orifice Pressure (psi)	27	40	53	66	78	91	104	116	129	32	46	60	74	88	102	116	130	144
0.132 Orifice Pressure (psi)	12	20	28	36	44	53	61	69	77	15	24	33	42	51	60	69	78	87
0.161 Orifice Pressure (psi)		6	12	17	23	28	34	39	45	3	9	15	21	27	33	39	45	51
GPM (per nozzle)	1.14	1.43	1.71	2.00	2.28	2.57	2.85	3.14	3.42	1.26	1.57	1.88	2.20	2.51	2.83	3.14	3.45	3.77
Flow Indicator 1/2" SS Ball Level	3.3	4.3	5.3	6.3						3.7	4.8	5.9	6.9					
Flow Indicator 7/16" SS Ball Level	1.0	1.8	2.5	3.3	4.0	4.7	5.5	6.2	7.0	1.3	2.1	3.0	3.8	4.6	5.4	6.2		

Speed (MPH)	60 Gallons Per Acre										65 Gallons Per Acre							
	4	5	6	7	8	9	10	11	12	4	5	6	7	8	9	10	11	12
0.075 Orifice Pressure (psi)	103	134	165	196	228	259	290	321	352	114	147	181	215	248	282	316	349	383
0.107 Orifice Pressure (psi)	37	53	68	83	99	114	129	144	160	43	59	76	92	109	125	142	158	175
0.132 Orifice Pressure (psi)	18	28	38	48	58	67	77	87	97	21	32	43	53	64	75	86	96	107
0.161 Orifice Pressure (psi)	5	12	18	25	32	38	45	51	58	7	15	22	29	36	43	50	57	65
GPM (per nozzle)	1.37	1.71	2.05	2.40	2.74	3.08	3.42	3.77	4.11	1.48	1.85	2.23	2.60	2.97	3.34	3.71	4.08	4.45
Flow Indicator 1/2" SS Ball Level	4.1	5.3	6.5															
Flow Indicator 7/16" SS Ball Level	1.6	2.5	3.4	4.3	5.2	6.1	7.0			1.9	2.9	3.9	4.8	5.8	6.8			

Speed (MPH)	70 Gallons Per Acre										75 Gallons Per Acre							
	4	5	6	7	8	9	10	11	12	4	5	6	7	8	9	10	11	12
0.075 Orifice Pressure (psi)	124	160	196	233	269	305	342	378	414	134	173	212	251	290	329	367	406	445
0.107 Orifice Pressure (psi)	48	66	83	101	119	137	155	172	190	53	72	91	110	129	148	167	186	206
0.132 Orifice Pressure (psi)	25	36	48	59	71	82	94	105	117	28	40	53	65	77	90	102	114	127
0.161 Orifice Pressure (psi)	10	17	25	33	40	48	56	64	71	12	20	28	37	45	53	61	70	78
GPM (per nozzle)	1.60	2.00	2.40	2.80	3.20	3.60	3.99	4.39	4.79	1.71	2.14	2.57	3.00	3.42	3.85	4.28	4.71	5.14
Flow Indicator 7/16" SS Ball Level	2.2	3.3	4.3	5.3	6.4					2.5	3.6	4.7	5.9	7.0				

NOTE - The values highlighted in green indicate pressures that are in the optimal pressure range of 20 - 50 psi. The row spacing is 30 inches.