

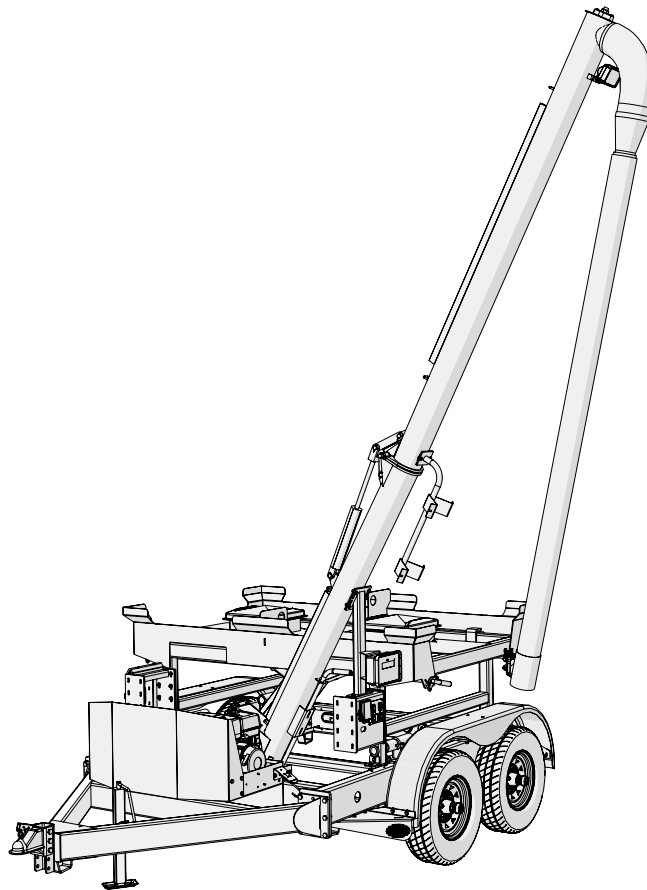

Manual

SPEEDTENDER PRO OPERATOR'S MANUAL

MODEL *Speedtender* ADVANCED SEED DELIVERY **251**



Rev. 2.20.2024

J&M Manufacturing Co, Inc

284 Railroad Street - P.O. Box 547 | Fort Recovery, OH 45846 | Ph: (419) 375-2376 | Fax: (419) 375-2708

www.jm-inc.com



Table Of Contents

To the Dealer	4
General Information	5
Safety Rules	6
Specifications	7
Decals	8
Bolt Torque Specifications	10
Operations	11
Hydraulic Power Service.....	15
General Service	16
Tire Service	17
Wheel Bearing Service	18
Brakes Service	19
Troubleshooting	22
Trailer Lights and Wiring.....	24
Scale Wiring	27
A-Frame	28
Gooseneck	29
Hydraulic Jack	30
Talc Hydraulics Schematic	32
Hydraulics Schematic	34
Seed Box Frame.....	36
Chutes.....	37
Chassis	38
Motor Mount	39
Axle Attachment.....	40
Scale Bar Mount	40
Battery Disconnect.....	40
Brakes and Hub Assembly	41
Auger	42
Auger Prop and Rest	44
Cleanout Door	45
Spare Tire.....	45
Talc.....	46



To the Dealer

TO THE DEALER

Read manual instructions and safety rules. Make sure all items on the Dealer's Pre-Delivery and Delivery Check Lists are completed before releasing equipment to the owner.

The dealer must complete the Warranty Registration found on the Dealer Portal website located at dealer.jm-inc.com and return it to J&M Mfg. Co., Inc. at the address indicated on the form. Warranty claims will be denied if the Warranty Registration has not been submitted.

EXPRESS WARRANTY:

J&M Mfg. Co. Inc. warrants against defects in construction or materials for a period of ONE year. We reserve the right to inspect and decide whether material or construction was faulty or whether abuse or accident voids our guarantee.

Warranty service must be performed by a dealer or service center authorized by J&M Mfg. Co., Inc. to sell and/or service the type of product involved, which will use only new or remanufactured parts or components furnished by J&M Mfg. Co., Inc. Warranty service will be performed without charge to the purchaser for parts or labor based on the Warranty Labor Times schedule. Under no circumstance will allowable labor times extend beyond the maximum hours indicated in the Warranty Labor Times schedule for each warranty procedure. The purchaser will be responsible, however, for any service call and/or transportation of the product to and from the dealer or service center's place of business, for any premium charged for overtime labor requested by the purchaser, and for any service and/or maintenance not directly related to any defect covered under the warranty. Costs associated with equipment rental, product down time, or product disposal are not warrantable and will not be accepted under any circumstance.

Each warranty term begins on the date of product delivery to the purchaser. Under no circumstance will warranty be approved unless (i) the product warranty registration card has been properly completed and submitted to the equipment manufacturer, and (ii) a warranty authorization number has been issued by the equipment manufacturer. This Warranty is effective only if the warranty registration card is returned within 30 days of purchase.

This warranty does not cover a component which fails, malfunctions or is damaged as a result of (i) improper modification or repair, (ii) accident, abuse or improper use, (iii) improper or insufficient maintenance, or (iv) normal wear or tear. This warranty does not cover products that are previously owned and extends solely to the original purchaser of the product. Should the original purchaser sell or otherwise transfer this product to a third party, this warranty does not transfer to the third party purchaser in any way. J&M Mfg. Co., Inc. makes no Warranty, express or implied, with respect to tires or other parts or accessories not manufactured by J&M Mfg. Co., Inc. Warranties for these items, if any, are provided separately by their respective manufacturers.

THIS WARRANTY IS EXPRESSLY IN LIEU OF ALL OTHER WARRANTIES OR CONDITIONS, EXPRESS, IMPLIED OR STATUTORY, INCLUDING ANY IMPLIED WARRANTY OF MERCHANTABILITY OR FITNESS FOR PARTICULAR PURPOSE.

In no event shall J&M Mfg. Co., Inc. be liable for special, direct, incidental or consequential damages of any kind. The exclusive remedy under this Warranty shall be repair or replacement of the defective component at J&M Mfg. Co., Inc.'s option. This is the entire agreement between J&M Mfg. Co., Inc. and the Owner about warranty and no J&M Mfg. Co., Inc. employee or dealer is authorized to make any additional warranty on behalf of J&M Mfg. Co., Inc.

The manufacturer reserves the right to make product design and material changes at any time without notice. They shall not incur any obligation or liability to incorporate such changes and improvements in products previously sold to any customer, nor shall they be obligated or liable for the replacement of previously sold products with products or parts incorporating such changes.

SERVICE:

The equipment you have purchased has been carefully manufactured to provide dependable and satisfactory use. Like all mechanical products, it will require cleaning and maintenance. Lubricate the unit as specified. Observe all safety information in this manual and safety signs on the equipment.

For service, your authorized J&M dealer has trained mechanics, genuine J&M service parts, and the necessary tools and equipment to handle all your needs.

Use only genuine J&M service parts. Substitute parts may void warranty and may not meet standards required for safety and satisfactory operation. Record the model number and serial number of your equipment in the spaces provided:

Model No: SpeedTender Pro 251 **Serial No:** _____ **Date of Purchase:** _____

Purchased From: _____

Provide this information to your dealer to obtain correct repair parts.



General Information

TO THE OWNER:

The purpose of this manual is to assist you in operating and maintaining your seed tender in a safe manner. Read this carefully. It furnishes information and instructions that will help you achieve years of dependable performance and help maintain safe operating conditions. If this machine is used by an employee or is loaned or rented, make certain that the operator(s), prior to operating:

1. Is instructed in safe and proper use.
2. Reviews and understands the manual(s) pertaining to this machine.

Throughout this manual, the term **IMPORTANT** is used to indicate that failure to observe can cause damage to equipment. The terms **CAUTION**, **WARNING** and **DANGER** are used in conjunction with the Safety-Alert Symbol, (a triangle with an exclamation mark), to indicate the degree of hazard for items of personal safety. When you see this symbol, carefully read the message that follows and be alert to the possibility of personal injury or death.



This Safety-Alert symbol indicates a hazard and means **ATTENTION! BECOME ALERT! YOUR SAFETY IS INVOLVED!**



DANGER

Indicates an imminently hazardous situation that, if not avoided, will result in death or serious injury.



WARNING

Indicates a potentially hazardous situation that, if not avoided, could result in death or serious injury, and includes hazards that are exposed when guards are removed.



CAUTION

Indicates a potentially hazardous situation that, if not avoided, may result in minor or moderate injury.

IMPORTANT

Indicates that failure to observe can cause damage to equipment.

NOTE

Indicates helpful information.

SAFETY RULES:



ATTENTION! BECOME ALERT! YOUR SAFETY IS INVOLVED!



Safety is a primary concern in the design and manufacture of our products. Unfortunately, our efforts to provide safe equipment can be erased by an operator's single careless act. In addition, hazard control and accident prevention are dependent upon the awareness, concern, judgment, and proper training of personnel involved in the operation, transport, maintenance and storage of equipment.

Make certain that the operator(s), prior to operating is instructed in safe and proper use and reviews and understands the manual(s) pertaining to this machine. Also make certain that the operator(s) reviews and understands the operator's manual of the tow vehicle prior to hooking up or operating the SpeedTender Pro.

Read this manual before you operate this machine. If you do not understand any part of this manual, or need more information, contact the manufacturer or your authorized dealer.

Safety Rules Continued on Next Page

Safety Rules

1. Understand that your safety and the safety of other persons are measured by how you service and operate this machine. Know the positions and functions of all controls before you try to operate them. Make sure to check all controls in a safe area before starting your work.
2. The safety information given in this manual does not replace safety codes, federal, state, or local laws. Make certain your machine has the proper equipment as designated by local laws and regulations.
3. A frequent cause of personal injury or death is from persons falling off equipment and being run over. Do not permit persons to ride on this machine.
4. Secure SpeedTender Pro safety chain to towing vehicle before transporting. Do not transport without safety chains being attached to tow vehicle.
5. Make sure that the auger is on the rest before transport.
6. Use good judgment when transporting SpeedTender Pro on a highway. Maintain complete control at all times. Regulate speed to road conditions.
7. When transporting on public roads, the auger must be folded in.
8. Do not travel faster than 10 mph during off highway travel. Drive slowly over rough ground, hill sides, and around curves to avoid tipping. Use extreme care when operating close to ditches, fences, or on hillsides.
9. Use care when moving or operating SpeedTender Pro near electric lines as serious injury or death can result from contact.
10. Never adjust, service, clean, or lubricate SpeedTender Pro until all power is shut off and the battery is disconnected. Keep all safety shields in place.
11. Carbon monoxide can cause severe nausea, fainting, or death. Do not operate engine in closed or confined work area.
12. Explosive fuel can cause fires and severe burns. Stop engine before filling fuel tank.
13. Hot parts can cause severe burns. Do not touch engine while operating or just after stopping.
14. Hydraulic oil leaking under pressure can penetrate skin and cause infection or other injury.
15. To prevent personal injury when working with hydraulic power unit:
 - a. Relieve all pressure before disconnecting fluid lines.
 - b. Before applying pressure, make sure all connections are tight and components are in good condition.
 - c. Never use your hand to check for suspected leaks under pressure. Use a piece of cardboard or wood for this purpose.
16. Make sure that everyone is clear of equipment before applying power or moving the SpeedTender Pro.
17. Never allow anyone, including children, in, near, or on the SpeedTender Pro during transport or during loading and unloading of seed. Be aware that moving seed is dangerous and can cause entrapment, resulting in severe injury or death by suffocation.
18. Before unhooking the SpeedTender Pro from the transport vehicle, be sure to properly block the wheels to prevent the SpeedTender Pro from moving.



Specifications

Specification	SpeedTender Pro 251
Capacity	2 (Two), 50 Unit Boxes (100 Total Units)
Weight (Empty)	2,850 lbs
Tongue Weight (Loaded)	650 lbs
Unload Rate	4 Minutes per Box
Axles	Two, 5,200 lbs Torsion-Flex Axles with Electric Brakes
Engine	13 hp Honda Motor with Electric Start

Dimensions	
A	16'-4"
B	21'-3"
C	4'-11.5"
D	4'-2"
E	8'-4"
F	9'-3"
G	12'-1"
H	13'-0"

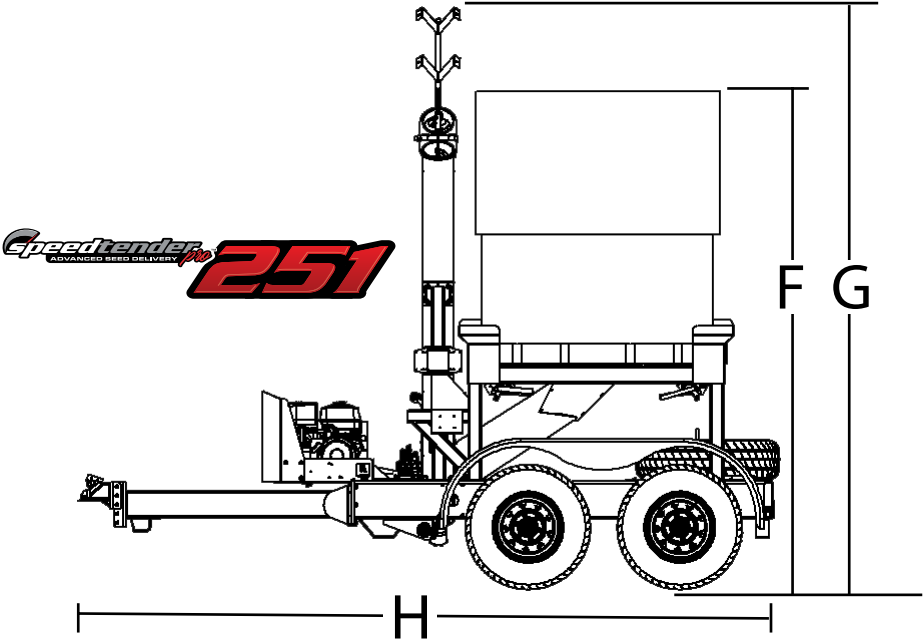
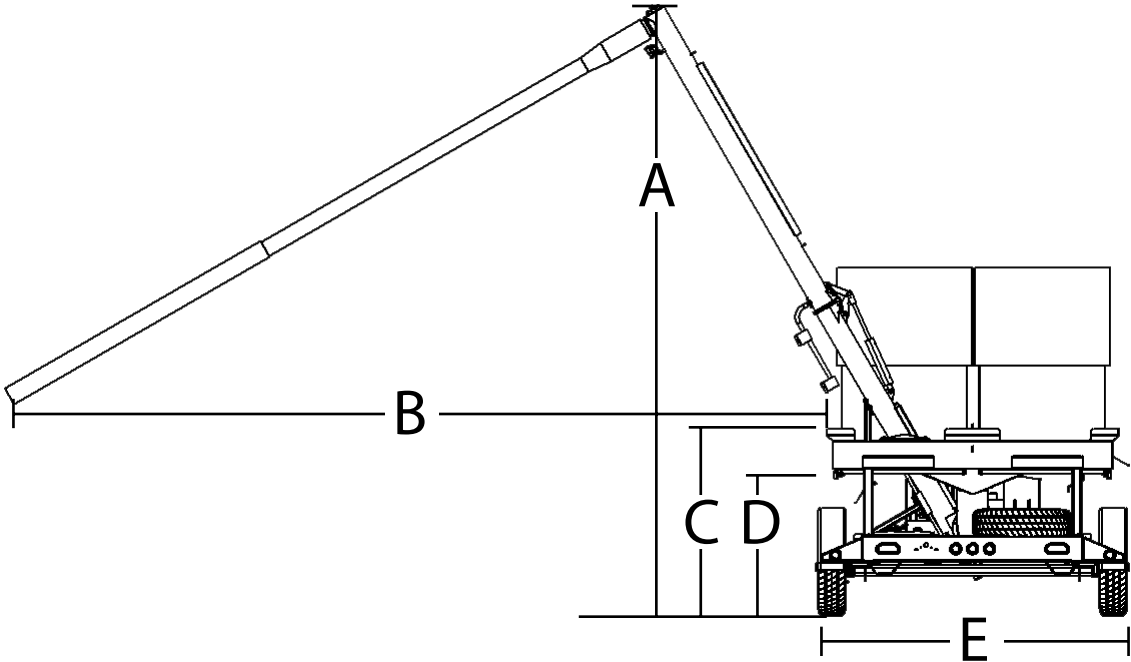

Speedtender
ADVANCED BIRD DELIVERY **251**



Decals

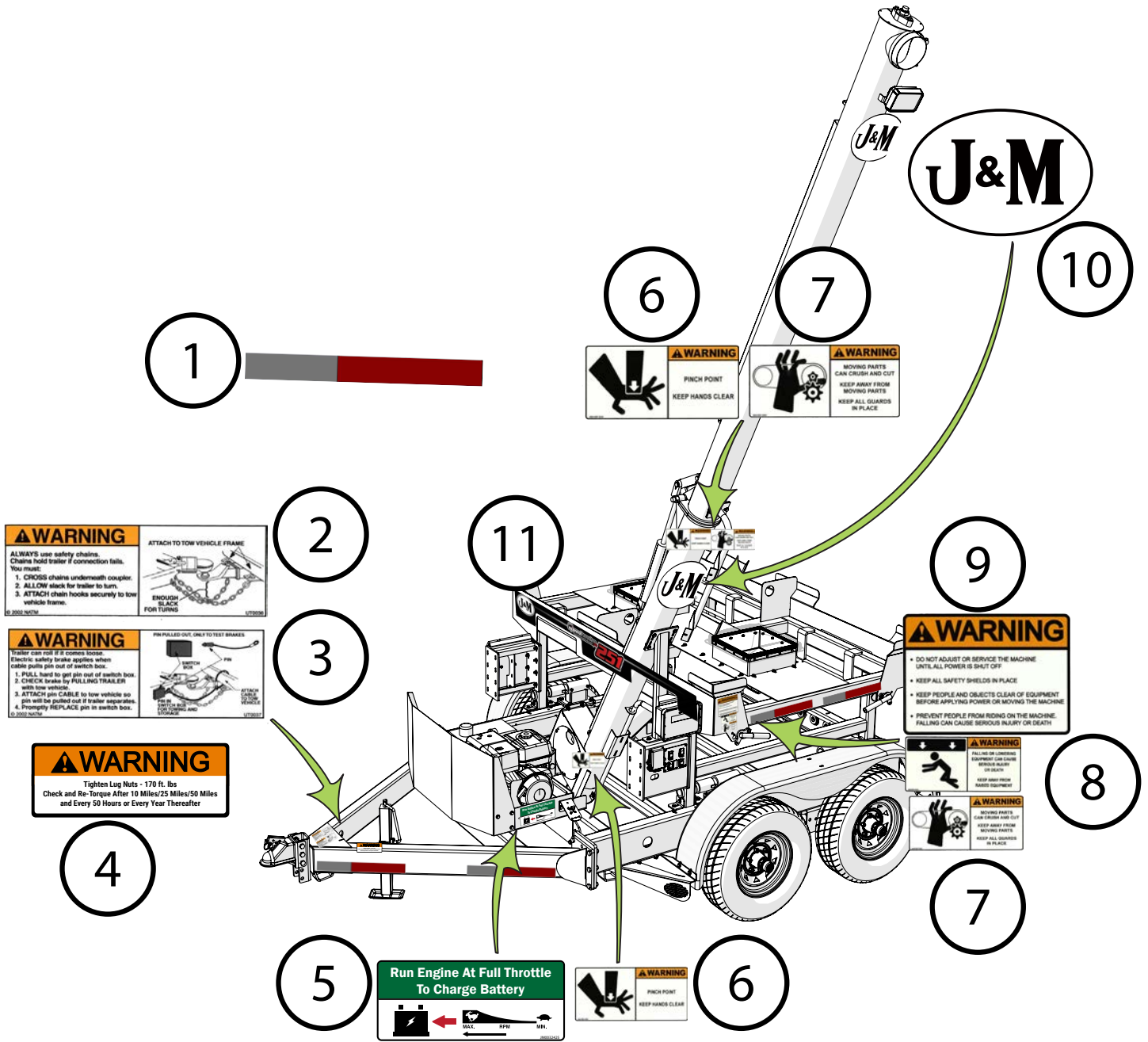

Decals

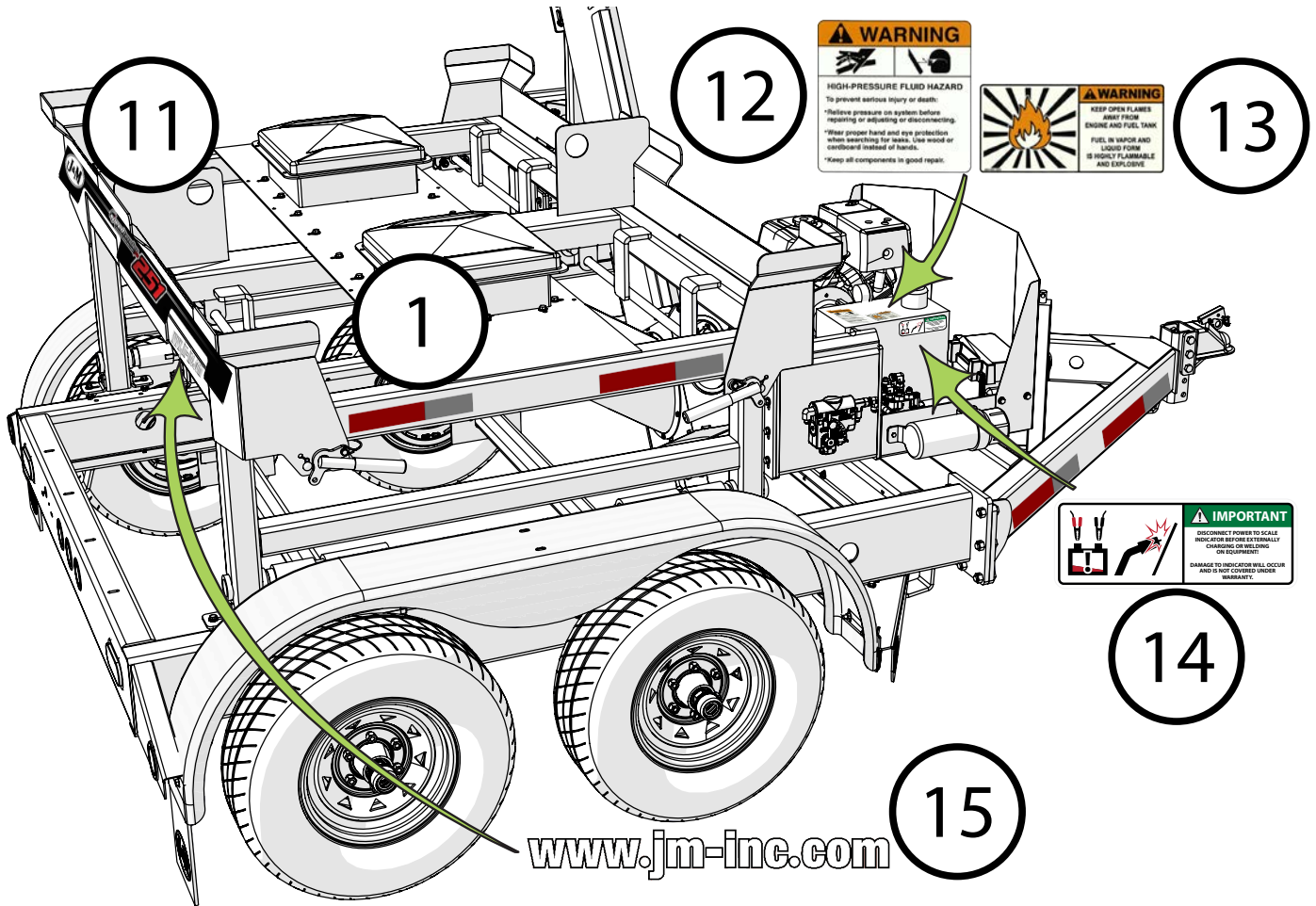

	Description	Part No.
1	2" x 18" Red and White Reflective Strip	JM0015079
2	Warning, Always Use Safety Chains Decal	JM0014995
3	Warning, Trailer Can Roll Decal	JM0014997
4	Warning, Tire Wheel or Lug Nut Failure Decal	JM0014996
5	Run Engine At Full Throttle To Charge Battery Decal	JM0032425
6	Warning, Pinch Point Decal	JM0014994
7	Warning, Moving Parts Can Crush and Cut Decal	JM0014993
8	Warning, Falling Or Lowering Decal	JM0014992
9	Warning, Do Not Adjust (4 Bullets) Decal	JM0018040
10	J&M Oval Decal (Medium) 5-1/2" x 8-1/2"	JM0010179
11	251 Decal	JM0079378
12	Warning, High Pressure Fluid Hazard Decal 4" x 4"	JM0010163
13	Warning, Keep Open Flames Away Decal	JM0014983
14	Important, Disconnect Power To Scale Decal	JM0040056
15	www.jm-inc.com Decal	JM0019239

Bolt Torque Specifications

Always tighten hardware to these values unless a different torque or tightening procedure is listed for specific application. Fasteners must always be replaced with the same grade as specified in the manual parts list. Always use the proper tool for tightening hardware. Make sure fastener threads are clean and you start thread engagement properly. **Use these values when tightening all bolts and nuts with the exception of wheel nuts.**

SAE Fasteners

Coarse Thread Series				
Diameter and Pitch (Inches)	Grade 5		Grade 8	
	Dry	Oiled	Dry	Oiled
1/4"-20	8 ft-lbs	6 ft-lbs	12 ft-lbs	9 ft-lbs
5/16"-18	17	13	25	18
3/8"-16	30	23	45	35
7/16"-14	50	35	70	55
1/2"-13	75	55	110	80
9/16"-12	110	80	150	110
5/8"-11	150	110	220	170
3/4"-10	260	200	380	280
7/8"-9	430	320	600	460
1"-8	640	480	900	680
Fine Thread Series				
Diameter and Pitch (Inches)	Grade 5		Grade 8	
	Dry	Oiled	Dry	Oiled
1/4"-28	10 ft-lbs	7 ft-lbs	14 ft-lbs	10 ft-lbs
5/16"-24	19	14	29	20
3/8"-24	35	25	50	40
7/16"-20	55	40	80	60
1/2"-20	90	65	120	90
9/16"-18	120	90	170	130
5/8"-18	180	130	240	180
3/4"-16	300	220	420	320
7/8"-14	470	360	660	500

Stud and Wheel Nut Torque Specifications

Always tighten hardware to these values unless a different torque or tightening procedure is listed for specific application. Fasteners must always be replaced with the same grade as specified in the manual parts list. Always use the proper tool for tightening hardware. Make sure fastener threads are clean and you start thread engagement properly. **Use these values when tightening all studs and wheel nuts.**

Stud	Tightening Torque
1/2"-20	120 ft-lbs
9/16"-18	170 ft-lbs
5/8"-18	300 ft-lbs
3/4"-16	400 ft-lbs
20mm	475 ft-lbs
22mm	640 ft-lbs

TIGHTENING WHEEL NUTS: Torque 1/2"-20 lug nuts on wheels to 120 ft-lbs after the first 10, 25, and 50 miles of driving, then recheck torque every 50 hours or every year, whichever comes first. Failure to do so may damage wheel nut seats. Once seats are damaged, it will become impossible to keep nuts tight.



Preparing the Towing Vehicle

Before towing the SpeedTender Pro, refer to towing vehicle's owner's manual for information concerning hitch capacities, hitch adjustments, and tire inflation.

Towing vehicle must be equipped with proper electric braking components.

NOTE: The SpeedTender Pro is equipped with LED lights. The towing vehicle may require a flasher upgrade for lights to operate properly.

Do not exceed towing vehicle's GVWR (Gross Vehicle Weight Rating) or GCWR (Gross Combination Weight Rating), or the maximum hitch load.

Preparing SpeedTender Pro

Hydraulics: Check routing of all hydraulic hoses. Hoses should not be kinked, twisted or rubbing against sharp edges. Check all hoses and fittings for hydraulic leaks. Tighten, repair, or replace as required.

Lubrication: Lubricate SpeedTender Pro as outlined in the service section of this manual "General Service" on page 16. Refer to engine manual for proper fluid levels in engine.

Tires/Wheels: Check tire pressures and maintain at recommended operating pressure. It is important to check wheel nut/bolts for proper torque as recommended. Refer to "Tire Service" on page 17 for proper tire pressure and "Bolt Torque Specifications" on page 10 for wheel torque specifications.

Connecting SpeedTender Pro to the Towing Vehicle

⚠ WARNING: Do not stand between the SpeedTender Pro and tow vehicle when hooking up.

NOTE: The SpeedTender Pro comes standard with a 2-5/16" ball coupler and has an optional 3" lunette eye. Also, the SpeedTender Pro offers an optional gooseneck frame in place of the A-Frame. The gooseneck frame can feature either a 2-5/16" ball coupler or a 5th wheel hook up.

1. Back tow vehicle up to SpeedTender Pro.
2. Align the vehicle's ball or lunette eye with the coupler or ring on the SpeedTender Pro.
3. Lift tongue latch lever.
4. Lower jack to set SpeedTender Pro coupler down on ball or lunette eye hook.
5. Latch coupler and insert pin. Check to make sure that coupler is securely latched.
6. A-Frame - Pivot jack to transport position and pin in place.
Gooseneck - Raise the "drop leg" of the jack.
7. Attach 7-way plug to tow vehicle. Check the length of the cord on the 7-way plug to make sure it is long enough to turn, but not too long to touch the ground.

NOTE: Check to make sure that lights are in proper operating condition and repair or replace if necessary.

8. Connect the brake breakaway cable to towing vehicle.
9. Attach safety chains to tow vehicle by crossing chains. Allow enough slack in chains to allow for turning.
10. Test the brakes and all the lights on the SpeedTender Pro.

⚠ WARNING: Check safety chains for broken, stretched or damaged link or end fittings. Replace chains if found to be damaged. Do not weld safety chains. Replace the safety chains immediately if you have an event where they are used near their max strength.

Operations



Attaching the bulk seed boxes

1. Unstrap and remove the chute covers.
2. Remove the lynch pins and rotate the clamp handles down.
3. Place a bulk seed box over each of the chutes.
4. Rotate the clamp handles up and reinstall the lynch pins.

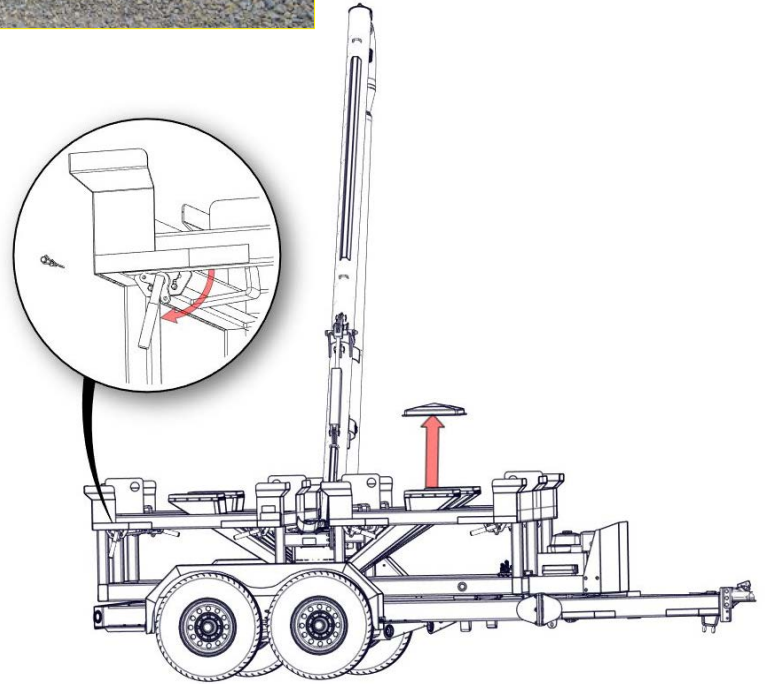

Transporting

NOTE: Move the jack to the horizontal position before transporting.

NOTE: Ensure the auger is in the auger rest and strapped down.

⚠ WARNING: Travel at a safe speed to maintain complete control of towing vehicle and SpeedTender Pro at all times.

Hydraulic Power Unit Operation

⚠ WARNING: Explosive fuel can cause fires and severe burns. Stop engine before filling fuel tank.

⚠ WARNING: Carbon monoxide can cause severe nausea, fainting or death. Do not operate engine in an enclosed or confined area.

⚠ WARNING: Hot parts can cause severe burns. Do not touch engine while operating or just after stopping.

⚠ WARNING: Acid from battery can cause fires and severe acid burns. Charge battery in well-ventilated area.

⚠ WARNING: Relieve hydraulic pressure before working on hydraulic system.

Operations

⚠ WARNING: Purge hydraulic system of air before operating SpeedTender Pro to prevent serious injury or death.

⚠ WARNING: Wear proper hand and eye protection when searching for leaks. Use wood or cardboard instead of hands.

1. Ensure all fittings and hardware are in proper operating condition. Replace if worn or broken. Check engine fluid levels and sight gauge on reservoir for proper operating levels.
2. Slide the fuel shut-off lever to the "ON" position.
3. Slide choke to the "ON" position.
4. Turn the key to the start position. Once engine starts, release key.
5. After starting, allow the engine to warm-up. Slide choke to the "OFF" position, and increase throttle speed.
6. To turn the engine off, slide the fuel shut-off lever to the "OFF" position.
7. Turn key off.

NOTE: In extremely cold weather, it is best to allow engine and hydraulics to warm up before increasing throttle speed.

NOTE: If a hydraulic leak appears, turn off immediately and take appropriate action.

NOTE: See engine operator's manual for more details on upkeep and service.

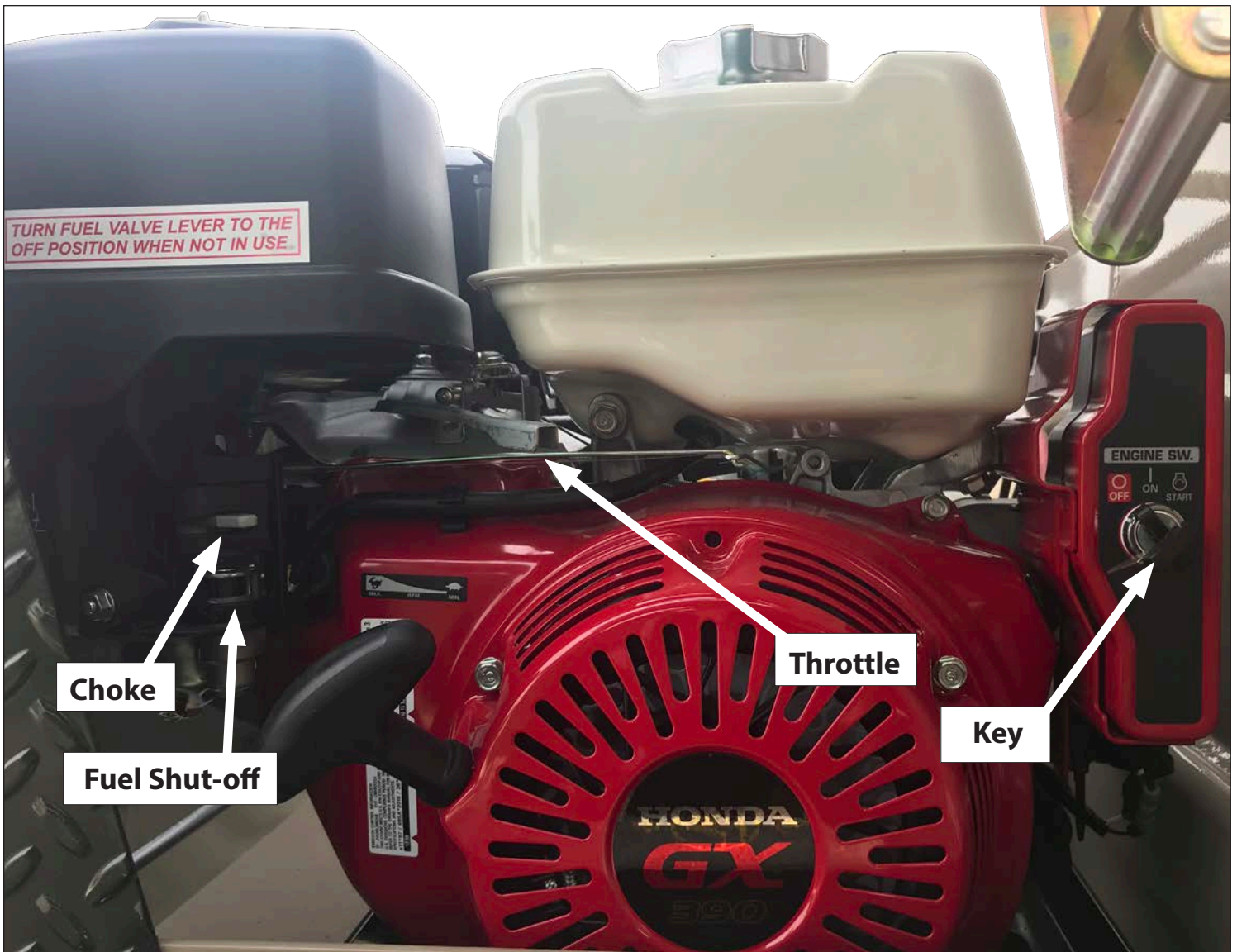

Operations

Field Operation

⚠ WARNING: The SpeedTender Pro must be hooked to the towing vehicle during loading and unloading.

1. Position the SpeedTender Pro next to the planter/drill so the auger will reach the planter box.
2. Start the hydraulic power unit and increase throttle speed. (Allow hydraulic fluid to warm up.)
3. Extend the auger to unload position using the handheld controller.
4. Use the 2 Switch Wired Remote or Key Fob to start the auger.
5. Fill the planter/drill to desired level, then repeat.
NOTE: Adjusting engine throttle will regulate auger speed.
6. The engine must throttle at, or above 80% throttle for 3 seconds to begin charge. After the 3 seconds at 80% throttle the battery will continue to charge until the engine is turned off.
7. Slide the fuel shut-off lever to the "OFF" position. This will allow the engine to shutoff by running out of gas.
8. Turn the key to the "OFF" position.

Reprogramming the Key Fob and Receiver:

Power up the unit. The LED on the receiver unit will flash red four times, indicating the unit has received power. Magnetically controlled switching circuitry is embedded in the receiver unit. Place a fairly powerful magnet on the back of the receiver for 3 seconds and remove it. The LED will change to a constant red state. Now press any button on the transmitter you are attempting to reprogram. The LED will change to a green/yellow color, confirming the receiver has picked up a signal from the transmitter, and subsequently learned that signal. Communication has been established and the key fob will function properly.

Troubleshooting:

If the above procedure does not complete successfully, wait until the LED light goes out and repeat the procedure. If you experience a second failure of the reprogramming, place the magnet on the back of the receiver. The LED will change to a constant red state. Leave the magnet in place on the receiver until the LED light goes out (approximately 10 seconds), which completely clears the receiver's memory. Once you have cleared the memory, proceed with the standard reprogramming procedure for the Key Fob transmitters.

Basic Scale Operations

1. Turn the scale "ON" by pressing the on/off button. The display shows "Hello" then the current weight value is displayed.
2. Press G/N to access the gross mode. (Live scale weight is displayed in the G/N weighing mode.)
3. In the gross mode, press the ZERO/CLEAR key to zero the indicator when the SpeedTender Pro is empty.
4. After initial amount is placed on the scale, press the TARE Key. (Weight is tared off and goes into net mode, showing weight).
5. Load or unload material as needed (Shows + when loading and a - value when unloading).
6. When the display reaches the proper amount, stop loading or unloading.
7. Repeat steps 2 through 4 until complete.

NOTE: For more information, refer to the scale operator's manual.

Auger Cleanout

1. Raise the clean out door on the auger.
2. Run the auger in reverse until all grain is removed.
3. Close the clean out door.



Hydraulic Power Service

Daily (every 5 hours of use):

1. Check oil level.
2. Inspect for oil leaks and repair as necessary.
3. Check all hoses, fittings, bolts and hardware to ensure they are secure and properly tightened.
4. Check motor oil level. See engine operator's manual for details on oil levels, oil types, and service intervals.

Once per season (every 20-25 hours of use):

Change hydraulic oil filter element with either a NAPA 1552 or a FRAM P1654A Filter.

Every two to three years (every 75-80 hours of use):

Drain oil reservoir and refill with clean, good quality hydraulic AW 32 oil. (It is not recommended to refill with tractor hydraulic oil).

Replacing hydraulic parts:

Refer to "Hydraulics Schematic" on page 34 for proper part description and part # for replacement.

Purge air from system as follows:

1. Disconnect the rod end clevis of all cylinders in a circuit and block up cylinders so the rod can completely extend and retract without contacting any other components.
2. Pressurize the system and maintain system at full pressure for at least 5 seconds after cylinder rods stop moving. Check that all cylinders have fully extended or retracted.
3. Check hydraulic reservoir and refill as needed.
4. Pressurize system again to reverse the motion of step 2. Maintain pressure on system for at least 5 seconds after cylinder rods stop moving. Check that cylinders have fully extended or retracted.
5. Check for hydraulic leaks using cardboard or wood.
6. Repeat steps 2, 3, 4 and 5 (3 to 4 times).
7. Depressurize hydraulic system and connect cylinder rod clevises to their mating lugs.



General Service

Daily Service (5 -10 Hours of Use)

NOTE: J&M recommends the following service to be performed daily (every 5-10 hours of use)

1. Check hydraulic oil level.
2. Inspect for oil leaks and repair as appropriate.
3. Check all hoses, fittings, bolts, and hardware to make sure they are secure and properly tightened.
4. Check engine oil level. See engine operator's manual for details on oil levels, oil types, and service intervals.
5. Check SpeedTender Pro brakes and lights before towing.
6. Check the SpeedTender Pro periodically for cracks in welds and for other structural damage. Have cracked welds fixed immediately.
NOTE: Failure to have cracked welds fixed immediately could result in extensive damage to the SpeedTender Pro and greatly reduce its life.
7. Ensure tires are properly inflated. Tire care guidelines can be found in "Tire Service" on page 17.
8. Ensure wheel lug nuts are properly torqued. See "Bolt Torque Specifications" on page 10.
9. Clean out the auger at the end of every day of use.

End of the Year Service

IMPORTANT: When the SpeedTender Pro is not going to be used for a length of time, J&M recommends that you store the SpeedTender Pro in a dry, protected place. Leaving your SpeedTender Pro outside and open to the weather will shorten its life.

1. The wheel bearings need to be cleaned, inspected, repacked, and adjusted. Use a number 2 wheel bearing grease to repack the bearings.
2. Inspect and service the brakes (magnets and shoes). They must be changed when they become worn or scored to prevent inadequate vehicle braking. Clean the backing plate, magnet arm, magnet, and brake shoes. Make certain all the parts removed are replaced in the same brake and drum assembly. Inspect the magnet arm for any loose or worn parts. Check shoe return springs, hold down springs, and adjuster springs for stretching or deformation. Replace as needed.
3. If equipped with talc, be sure to empty talc box entirely and run the talc auger to completely empty talc from the auger pipe.
4. Torque lug-nuts (See "Bolt Torque Specifications" on page 10).
5. Ensure tires are properly inflated. Tire care guidelines can be found in "Tire Service" on page 17.
6. Remove all grain from inside the chutes.
7. Clean out the auger at the end of every season
8. Check the SpeedTender Pro periodically for cracks in welds and for other structural damage. Have cracked welds fixed immediately.
NOTE: Failure to have cracked welds fixed immediately could result in extensive damage to the SpeedTender Pro and greatly reduce its life.
9. Check hydraulic hoses for wear and replace if needed.
10. Remove battery from the SpeedTender Pro and place in a cool, dry place.
NOTE: Attaching a trickle charger to the battery will help ensure a long life for your battery.
IMPORTANT: Be sure to disconnect the scales from the battery before charging.
11. Change hydraulic oil filter element with either a NAPA 1552 or a FRAM P1654A Filter.
12. Top off hydraulic oil tank with good quality hydraulic AW 32 oil.
NOTE: If the hydraulic oil appears to be "milky" in color, it should be changed immediately. Otherwise, the hydraulic oil should be changed every 2-3 years. If the environment is extremely dusty or dirty the hydraulic oil should be changed more often.
13. Check motor oil level. See engine operator's manual for details on oil levels, oil types, and service intervals.
14. Retract all hydraulic cylinders to prevent the piston rods from rusting.
15. Touch up spots where paint has worn away (use good quality primer paint - especially before applying graphite paint to the inside of the grain tank).

Removing From Storage

1. Torque lug-nuts (See "Bolt Torque Specifications" on page 10).
2. Make sure that the tires are properly inflated. Tire care guidelines can be found in "Tire Service" on page 17.
3. Check oil level.
4. Inspect for hydraulic oil leaks and repair as appropriate.
5. Check all hoses, fittings, bolts, and hardware to ensure they are secure and properly tightened.
6. Check engine oil level. See engine operator's manual for details on oil levels, oil types, and service intervals.
7. Check SpeedTender Pro brakes and lights before each use.
8. Reattach battery and check to make sure it is fully charged.
IMPORTANT: Be sure to disconnect the scales from the battery before charging.



Tire Service

Tire Pressure

The following is to be used as a general guide for tire inflation. Figures can vary depending on specific brand of tire used. It is important that tires are inspected before and after unit is loaded. Start with the minimum pressure indicated. The tire should stand up with no side wall buckling or distress as tire rolls. Do not exceed maximum recommended tire pressure. **ST225/75D15 tires are standard on the SpeedTender Pro and should be inflated to 65 psi.** J&M also recommends rotating your tires front to back (not side to side) every 1,200 miles or 12 months (whichever comes first) for longer tire life. The image below is a troubleshooting chart used to ensure the tires wear evenly.

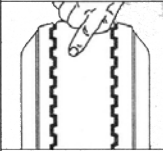
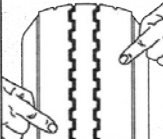
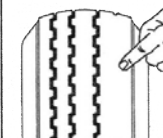
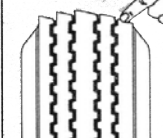
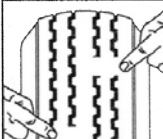
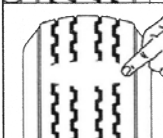
	Condition	Possible Cause	Remedy
	Even Center Wear	Over Inflation	Check & Adjust Pressure When Cold
	Inside & Outside Wear	Under Inflation	Check & Adjust Pressure When Cold
	Smooth, Side Wear - One Side	Loss of Camber or Overloading	Check & Unload As Necessary Have Alignment Checked
	"Feathering" Across The Face	Axle Not Square To Frame or Incorrect Toe In	Square Axles Have Alignment Checked
	Cupping	Loose Bearings or Wheel Balance	Check Bearing Adjustment and Wheel & Tire Balance
	Flat Spots	Wheel Lockup	Adjust Brakes

Wheel Bearing Service

Clean, inspect, and repack the wheel bearings every 12 months or 12,000 miles. Use a number 2 wheel bearing grease to repack the bearings.

Bearing Inspection and Service:

1. Jack up SpeedTender Pro.
2. Remove wheel nuts.
3. Remove wheel from hub.
4. Remove grease cap.
NOTE: Be careful not to dent or cut a hole in grease cap.
5. Remove the cotter pin, nut, and washer.
6. Wiggle the hub to take the outer wheel bearing out.
7. Pull hub assembly straight off the axle. If you want to reuse the grease seal, (which is not recommended), be careful to support the weight of the hub so that the end of the axle does not ruin the rubber part of the grease seal.
8. To remove the inner bearing, you must remove the grease seal.
9. Remove inner bearing.
10. Wash all grease and oil from the bearing cone using a suitable solvent. Dry the bearing with a clean, lint-free cloth and inspect each roller completely. If any pitting, scalding, or corrosion is present, then the bearing must be replaced. The bearing cups inside the hub must be inspected.
NOTE: Bearings must always be replaced in sets of a cone and a cup.
11. Repack inner bearing with new grease.
 - A. Place a moderate amount of grease in the palm of one hand.
 - B. Hold the inner bearing, large side down, in your other hand.
 - C. Using the edge of the bearing like an ice cream scoop, work it in until you see fresh grease come out of the top side of the bearing.
 - D. Rotate 1/8 of a turn and repeat until the whole bearing is full of fresh grease.
12. Place the inner bearing in the back of the wheel hub and add a liberal dose of grease.
13. Position the new wheel seal in its recess and lightly set it with a hammer.
NOTE: Be careful to not deform the metal part of the seal.
14. Slide the hub assembly onto the spindle and push it back into position.
15. Grease the outer bearing by hand, repeating the procedure used with the inner bearing in step 11.
16. Slide the outer bearing and the spindle washer onto the spindle and into the hub recess.
17. Install and bottom out the spindle nut, then back it off 1/4 turn.
18. Reinstall the spindle nut and replace the cotter pin with a new one.
NOTE: If the castle nut does not line up with the hole in the spindle, then loosen the nut slightly until it does.
19. Pack the bearing cap with fresh grease and lightly drive it into the hub recess with a hammer.
20. Reinstall the wheel onto the hub and torque the wheel nuts. See "Bolt Torque Specifications" on page 10.

Bearing cup replacement:

1. Place the hub on a flat work surface with the cup to be replaced on the bottom side.
2. Using a brass drift punch, carefully tap around the small diameter end of the cup to drive it out.
3. After cleaning the hub bore area, replace the cup by tapping it with the brass drift punch. Be sure the cup is seated all the way up against the retaining shoulder in the hub.



Brakes Service

The SpeedTender Pro is equipped with electric brakes. They need to be inspected and serviced immediately if a loss of performance is experienced. You need to service your SpeedTender Pro brakes at least once a year with normal use.

How to use your electric brakes properly:

Your SpeedTender Pro brakes are designed to work in synchronization with your tow vehicle brakes. Never use your tow vehicle or SpeedTender Pro brakes alone to stop the combined load.

Your SpeedTender Pro and tow vehicle will seldom have the correct amperage flow to the brake magnets to give you comfortable, safe braking unless you make proper brake system adjustments. Changing trailer load and driving conditions, as well as uneven alternator and battery output, can mean unstable current flow to your brake magnets. It is therefore imperative that you maintain and adjust your brakes as set forth in this manual, use a properly modulated brake controller, and perform the synchronization procedure noted below.

In addition to the synchronization adjustment detailed below, electric brake controllers provide a modulation function that varies the current to the electric brakes with the pressure on the brake pedal or amount of deceleration of the tow vehicle. It is important that your brake controller provide approximately 2 volts to the braking system when the brake pedal is first depressed and gradually increases the voltage to 12 volts as brake pedal pressure is increased. If the controller "jumps" immediately to a high voltage output, even during a gradual stop, then the electric brakes will always be fully energized and will result in harsh brakes and potential wheel lockup.

To synchronize:

To ensure safe brake performance and synchronization, read the brake controller manufacturer's instruction completely before performing the synchronization procedure.

Make several hard stops from 20 mph on a dry, paved road that is free of sand and gravel. If the SpeedTender Pro brakes lock and slide, decrease the gain setting on the controller. If they do not slide, slightly increase the gain setting, Adjust the controller just to the point of impending brake lockup and wheel skid.

How to adjust electric brakes:

1. Park the SpeedTender Pro on firm and level ground.
2. Block the trailer tires on the opposite side securely so that no forward or rearward movement is possible.
3. Jack up the SpeedTender Pro.
4. Secure the front and rear of the trailer on jack stands of adequate capacity.
5. At the back of the wheel, on the brake backing plate, there is a small rubber plug near the bottom of the backing plate. Pry out this plug to give access to the star wheel adjuster.
6. Insert the brake adjuster tool and maneuver it so that the tool engages with the teeth in the star wheel. The star wheel looks like a gear with exposed teeth on the perimeter.
7. Turn the adjuster until the brake locks up (you can no longer rotate the wheel by hand). This centers the brake shoes on the brake drum so they are in the correct position.
8. Back off the star wheel 8-10 clicks or as specified by the manufacturer. The wheel should spin freely with no apparent drag to slow it down. A slight scraping noise is normal as the wheel turns.
9. Repeat this procedure for all the wheels.

When to adjust brakes:

1. After the first 200 miles of operating when the brake shoes and drums have "seated."
2. At 3,000 mile intervals or once a year, whichever comes first.

Brake Cleaning and Inspection:

Your SpeedTender Pro brakes must be inspected and serviced at yearly intervals, (or more often as use and performance requires). Magnets and shoes must be changed when they become worn or scored to prevent inadequate vehicle braking. Clean the backing plate, magnet arm, magnet, and brake shoes. Make certain all the parts removed are replaced in the same brake and drum assembly. Inspect the magnet arm for any loose or worn parts. Check shoe return springs, hold down springs, and adjuster springs for stretching or deformation and replace if required.



Brakes Service

Brake Shoe and Lining Inspection:

A simple visual inspection of your brake linings will tell if they are usable. Replacement is necessary if the lining is worn (to within 1/16" or less), contaminated with grease or oil, or abnormally scored or gouged. Hairline heat cracks are normal in bonded linings and should not be cause for concern. When replacement is necessary, it is important to replace both shoes on each brake and both brakes of the same axle. This will help retain the "balance" of your brakes.

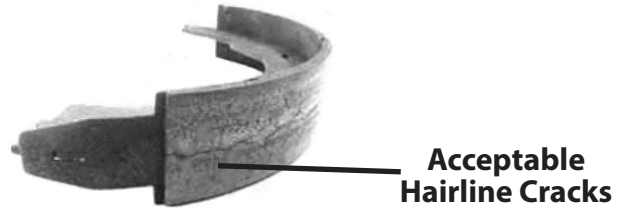

Replacing Brake Linings:

1. Remove the brake shoe retract spring.
2. Remove the shoe hold down assembly by holding the back of the pin with one hand and pushing against the spring and twisting with a hold down spring tool until the cup is released.
3. Remove both shoes together leaving the adjuster assembly and spring intact.
4. Clean the backing plate and lever arm.
5. Inspect magnet arm for any loose or worn parts.
6. Replace springs that are broken, bent, or weak.
7. Apply a light film of lubricant to the anchor pin and shoe rest pads & backing plate areas that are in contact with the lever arm.
8. Attach the adjuster screw and spring to the new brake shoes. The star wheel and adjuster must be positioned as before.
9. Install the new shoes on the backing plate and reinstall shoe retract spring.

After replacement of brake shoes and linings, the brake must be re-burnished to seat in the new components. This should be done by applying the brakes 20-30 times from an initial speed of 40 mph, slowing the vehicle to 20 mph. Allow ample time for brakes to cool between applications. This procedure allows the brake shoes to seat into the drum surface.

Brake Lubrication:

Before reassembling, apply a light film of lubrication or similar grease, or anti-seize compound on the brake anchor pin, the actuating arm bushing and pin, and the areas of the backing plate that are in contact with the brake shoes and magnet lever arm. Apply a light film of grease on the actuating block mounted on the actuating arm.

Troubleshooting:

Mechanical causes are ordinarily obvious, bent or broken parts, worn out linings or magnets, seized lever arms or shoes, scored drums, loose parts, etc. Most electric brake malfunctions that cannot be corrected by either brake adjustments or synchronization adjustments can generally be traced to electrical system failure. Voltmeter and ammeter are essential tools for proper troubleshooting of electric brakes.

How to Measure Voltage:

System voltage is measured at the magnets. Connect the voltmeter to the two magnet lead wires at any brake. This may be accomplished by using a pin probe inserted through the insulation of the wires dropping down from the chassis or by cutting the wires. **The engine of the towing vehicle should be running when checking the voltage (so that a low battery will not affect the readings).**

Brake Magnet Inspection:

Your electric brakes are equipped with high quality electromagnets that are designed to provide the proper force and friction. Your magnets should be inspected and replaced if worn unevenly or abnormally (as shown below). Even if wear is normal as indicated by your straightedge, the magnets should be replaced if any part of the magnet coil has become visible through the friction material facing of magnet. It is also recommended that the drum armature surface be re-faced when replacing magnets. Magnets should also be replaced in pairs - both sides of an axle.

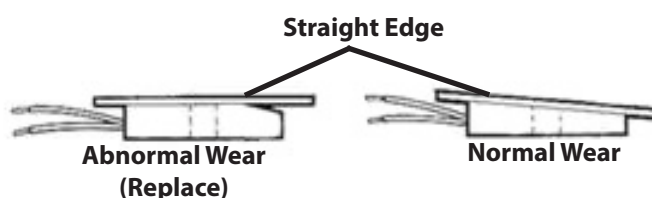

Brakes Service

Voltage in the system should begin at 0 volts. As the controller bar is slowly actuated, the voltage should gradually increase to approximately 12 volts, which is referred to as modulation. No modulation means when the controller begins to apply voltage to brakes, it applies an immediate high voltage, which causes the brakes to apply instantaneous maximum power.

The threshold voltage of a controller is the voltage applied to the brakes when the controller first turns on. The lower the threshold voltage, the smoother the brakes will operate. Threshold voltage in excess of 2 volts (quite often found in heavy duty controllers) can cause grabbing, resulting in harsh braking.

How to Measure Amperage:

System amperage is the amperage being drawn by all brakes on the trailer. **The engine of the towing vehicle should be running when checking amperage.**

One place to measure system amperage is at the blue wire of the controller, which is the output to the brakes. The blue wire must be disconnected and the amp meter put in series into the line. System amperage draw should be as noted in the table below. Make sure your ammeter has sufficient capacity and note polarity to prevent damaging your amp meter.

Brake Size	Amps/Magnet	Two Brakes	Four Brakes	Six Brakes	Magnet Ohms
12 X 2	3.0	6.0	12.0	18.0	3.2

Replacing brake magnet:

1. Orient the magnet over the lever arm post such that the magnet leads are in the correct position for routing.
2. Push the magnet over the lever arm post by compressing the magnet spring between the magnet and the lever arm.
3. Insert the magnet clip in the slot of the magnet. Be sure to orient the magnet clip so it will "snap" into place.
4. Press down on the magnet and install the magnet clip.
5. Be sure that the magnet moves up and down freely on the lever arm post.
6. Route the wiring in the same manner noted on removal. Be sure that wires cannot bind, pinch, or rub. Manually actuate lever arm to ensure there is no interference.
7. Install strain relief bushing, allowing enough slack in the wiring to allow the lever arm to move without straining the wires. Be sure the wire cannot come in contact with the armature.
8. Connect the magnet leads to the trailer wiring harness and then reinstall hub and drum.

Brake Drum Inspection:

There are two areas of the brake drum that are subject to wear and require inspection. These two areas are the drum surface where the brake shoes make contact during stopping and the armature surface where the magnet contacts (only in electric brakes).

The drum surface should be inspected for excessive wear or heavy scoring. If worn more than .020" oversized, or if the drum has worn out of round by more than .015", then the drum surface should be turned. If scoring or other wear is greater than .090" on the diameter, the drum must be replaced. When turning the drum surface, the maximum re-bore diameter for a 12" brake drum is 12.090"

The machined inner surface of the brake drum that contacts the brake magnet is called the armature surface. If the armature surface is scored or worn unevenly, it should be refaced to a 120 micro inch finish by removing not more than .030" of material. To ensure proper contact between the armature face and the magnet face, the magnets should be replaced whenever the armature surface is refaced and the armature surface should be refaced whenever the magnets are replaced.

Troubleshooting

Problems	Solutions
Unit sways during travel	a. Check tire pressure (see "Tire Service" on page 17).
	b. Check tow vehicle for loosened hitch parts.
	c. Check tow vehicle's hitch height.
	d. Reduce towing speed.
	e. Check wheel lug nuts (see "Bolt Torque Specifications" on page 10).
	f. Check wheel bearings for adjustment (see "Wheel Bearing Service" on page 18).
Tires show excessive wear	a. Check tire pressure.
	b. Rotate tires (see "Tire Service" on page 17).
	c. Check wheel bearings for adjustment. (See "Wheel Bearing Service" on page 18).
Wheel makes grinding or squeaking noise	a. Service wheel bearings (see "Wheel Bearing Service" on page 18).
Noisy when brakes are being applied	a. Properly adjust brakes (see "Brakes Service" on page 19).
	b. Replace any weak or broken springs in brakes.
	c. Replace the brake linings if excessively worn or contaminated.
	d. Check wheel bearings for adjustment (see "Wheel Bearing Service" on page 18).
No brakes	a. Properly adjust brakes (see "Brakes Service" on page 19).
	b. Check for short in electric circuit.
	c. Replace any brake magnets that are worn or defective.
Weak brakes	a. Properly adjust brakes (see "Brakes Service" on page 19).
	b. Replace any excessively worn or contaminated linings.
	c. Check for short in electric circuit.
	d. Replace bent backing plate.
Dragging brakes	a. Properly adjust brakes (see "Brakes Service" on page 19).
	b. Replace any weak or broken springs in brakes.
	c. Clean and lubricate the brake assemblies.
Locking brakes	a. Replace any weak or broken springs in brakes.
	b. Replace any excessively worn or contaminated linings.
Grabbing brakes	a. Replace any excessively worn or contaminated linings.
Surging brakes	a. Trailer is not adequately grounded.
Auger hydraulic pump is not producing sufficient pressure or volume to auger motor	a. Check for pinched or leaking hydraulic line.
	b. Allow hydraulic oil to warm up .
	c. Increase engine RPM.
	d. Charge battery or plug in to tow vehicle.
	e. Hydraulic fluid level low.
	f. Hydraulic filter clogged.
	g. Check for proper oil viscosity.
	h. Check hydraulic output pressure.
Auger is not moving - Obstructed auger	a. Make sure auger is not clogged.
Auger has insufficient output speed or RPM - Hydraulic pump is not producing sufficient pressure or volume to auger motor	a. Check for pinched or leaking hydraulic lines.
	b. Allow hydraulic oil to warm up.
	c. Increase engine RPM.
	d. Hydraulic fluid level low.
	e. Hydraulic filter clogged.
	f. Check for proper oil viscosity.
	g. Repair or replace worn out pump.
Auger has insufficient output speed or RPM	a. Check telescoping spout and auger for a clog.
	b. Remove material from clean out door.

Troubleshooting

Problems	Solutions
Auger has insufficient output speed or RPM - Air in hydraulic system	a. Bleed air out of hydraulic system and fill reservoir (See "Hydraulic Power Service" on page 15).
	b. Look for leaking or cracked fittings.
Auger has insufficient output speed or RPM - Leak in motor, valve body, or bypass valves	a. Replace or repair motor, valve body, or bypass valves.
	b. Check for proper oil viscosity.
Auger will not move up or down - Hydraulic pump is not producing sufficient pressure or volume to hydraulic cylinder	a. Check for pinched or leaking hydraulic lines.
	b. Allow hydraulic oil to warm up.
	c. Increase engine RPM.
	d. Hydraulic fluid level low.
	e. Hydraulic filter clogged.
	f. Check for proper oil viscosity.
	g. Check to see if hydraulic pump is worn out.
	h. Make sure battery is fully charged.
	i. Check wiring to valve body and hydraulic pump.
Hydraulic unit squeals	a. Check sight glass on hydraulic unit reservoir and fill if necessary.
	b. Run engine at reduced speed for 5-10 minutes to warm up fluid.
	c. Clean/replace filler cap/breather.
	d. Clear obstruction in suction hose.
	e. Replace plugged/dirty oil filter element.
Hydraulic unit has poor performance at high RPM	a. Clean pressure relief in control valve or replace.
	b. Check sight glass on hydraulic unit reservoir and fill if necessary.
	c. Replace plugged/dirty oil filter element.
	d. Charge battery.

Trailer Lights and Wiring

This table will be used for the following section, Lights and Wiring, on Pages 24-26:

	Description	Part No.
1	2-1/2" Red Round LED Light/Reflector Assembly (RRLA1)	JM0001905
2	2-1/2" Red Round LED Light/Reflector (RRLR1)	JM0001901
3	Round Grommet for LED 2-1/2" Light/Reflector	JM0001902
4	2-1/2" Amber Round LED Light/Reflector Assembly (ARLA1)	JM0001908
5	2-1/2" Amber Round LED Light/Reflector	JM0001895
6	Red Oval Brake Light LED Assembly (BLSTOA1)	JM0001903
7	Red Oval Brake Light LED (BLSTOL1)	JM0007114
8	Oval Grommet for Brake Light LED (OVLG1)	JM0001897
9	LED Field Light with Weather Pack Connectors (SpeedTender, NitroGro)	JM0050942
10	ST Main Harness (419-475)	JM0033700
11	ST Front Chassis Wiring Harness (419-385)	JM0019963
12	ST Rear Top Lights Harness (419-390)	JM0019964
13	V-Belt A-Frame 7-Way Trailer Connection	JM0046142
14	V-Belt Gooseneck 7-Way Trailer Connection	JM0046143
15	Breakaway Switch with Cable (BAS-1)	JM0001843

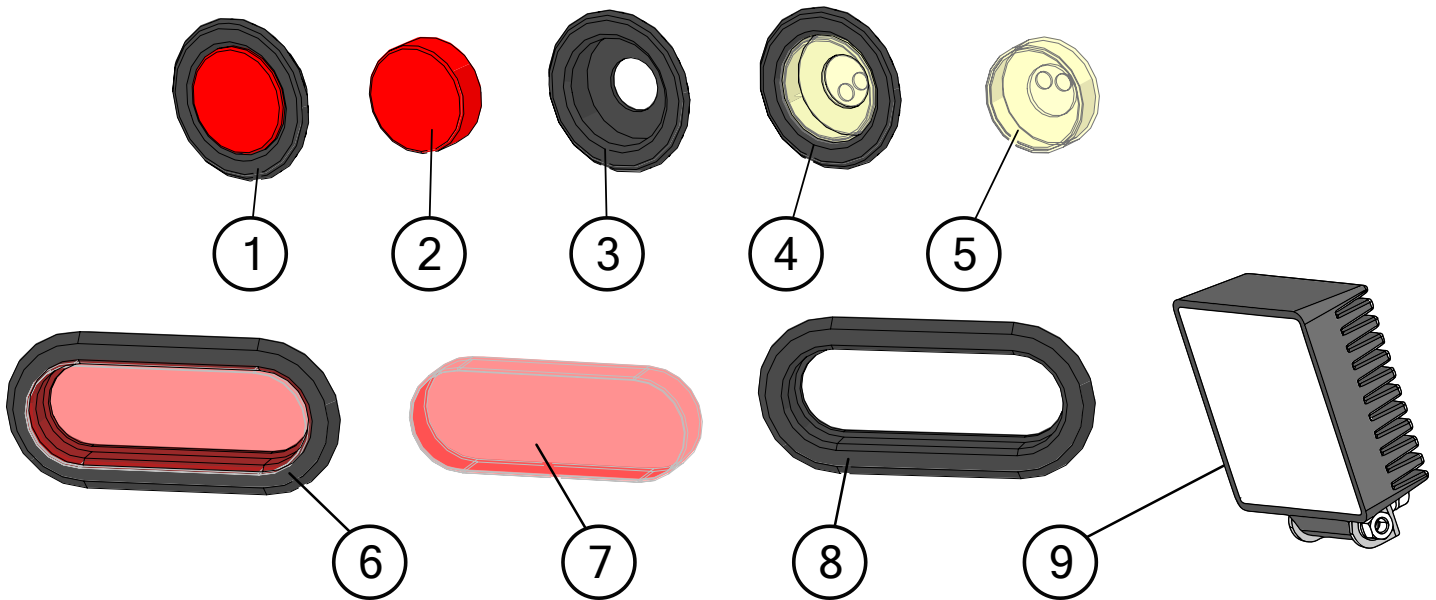

Trailer Lights and Wiring

10 ST Main Harness (419-475) (JM0033700)

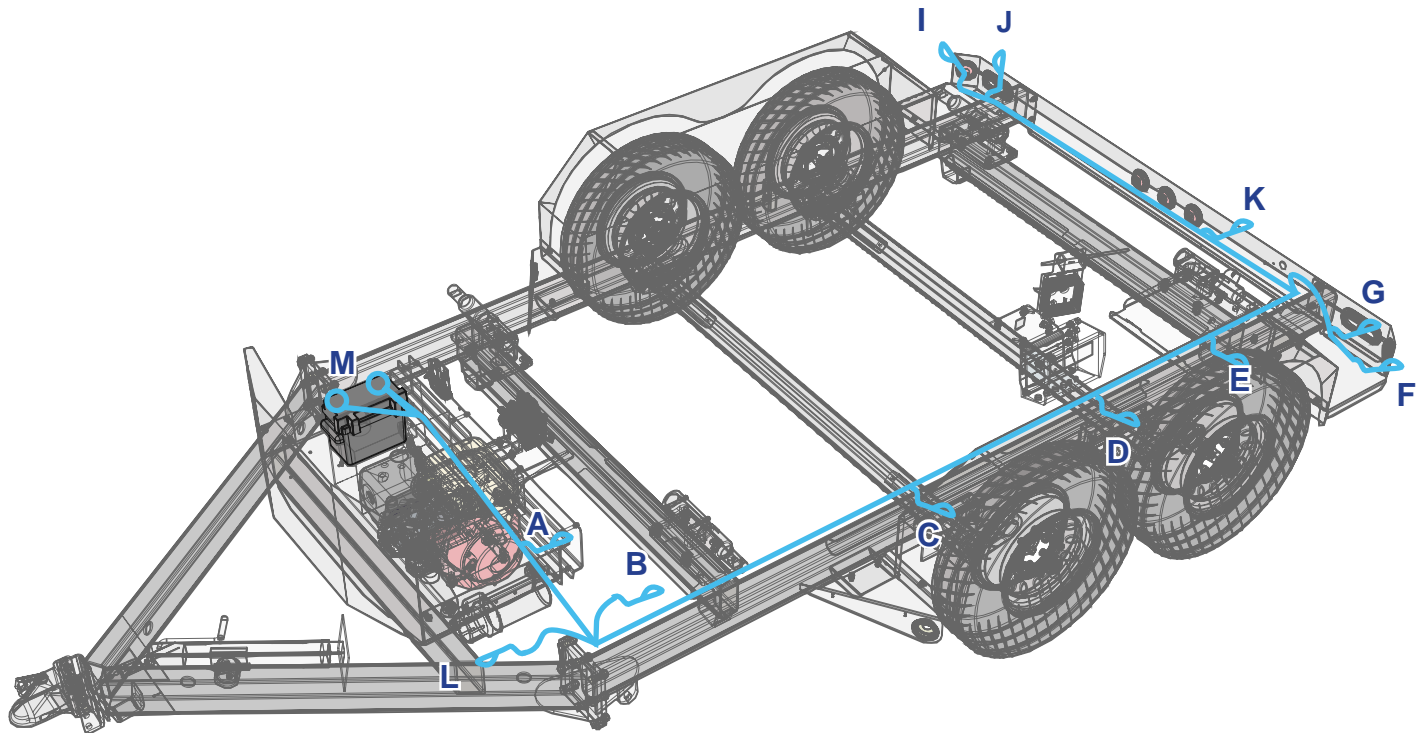
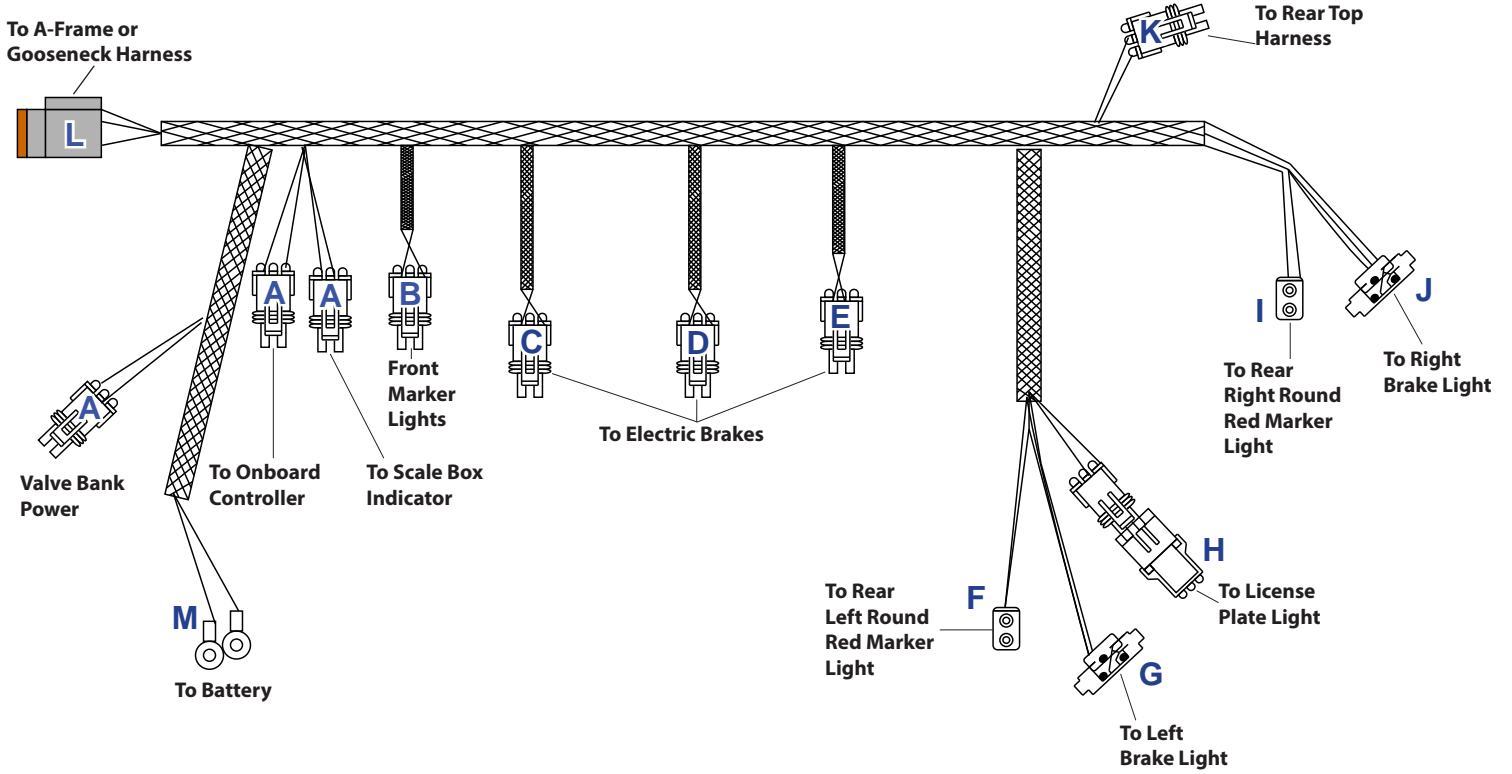

Trailer Lights and Wiring

11 ST Front Chassis Wiring Harness (419-385) (JM0019963)

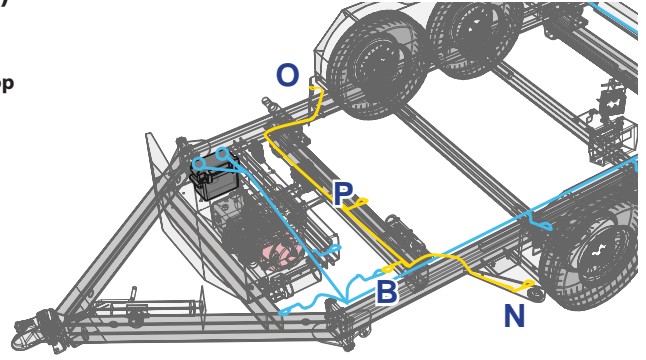
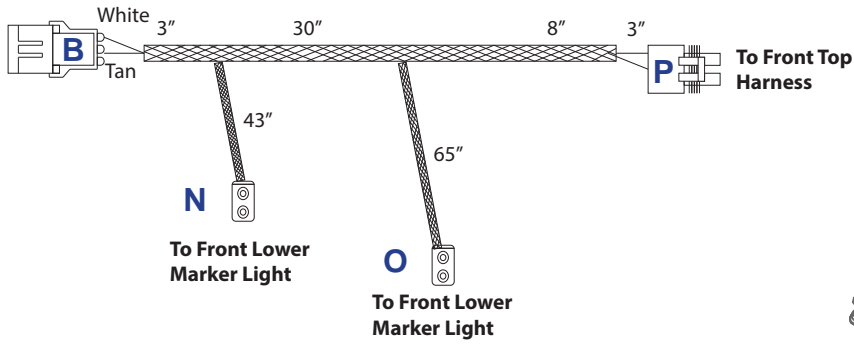

12 ST Rear Top Lights Harness (419-390) (JM0019964)

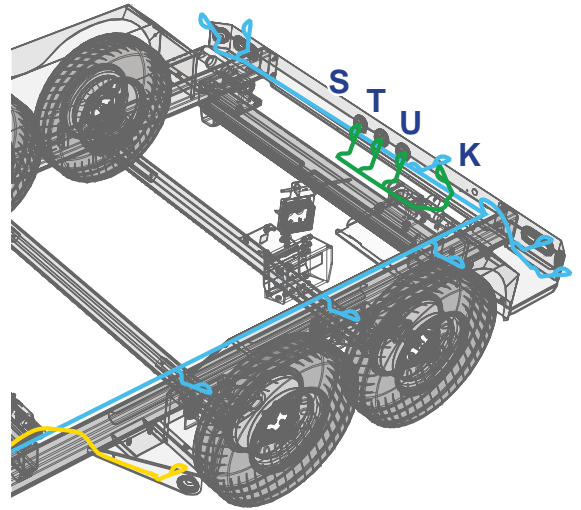
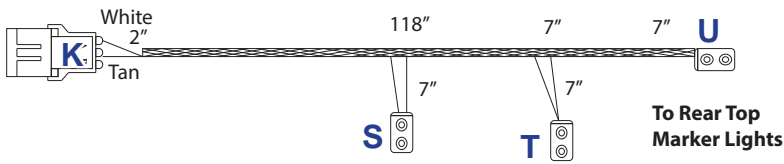

13 V-Belt A-Frame 7-Way Trailer Connection (JM0046142)

14 V-Belt Gooseneck 7-Way Trailer Connection (JM0046143)

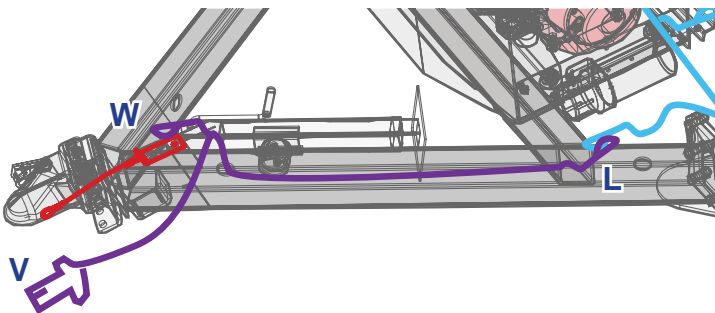
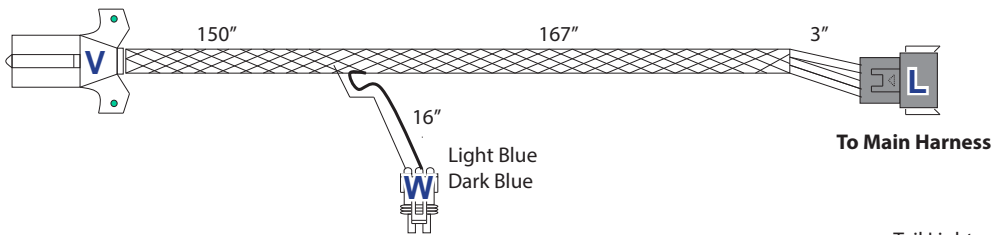

15 Breakaway Switch with Cable (BAS-1) (JM0001843)

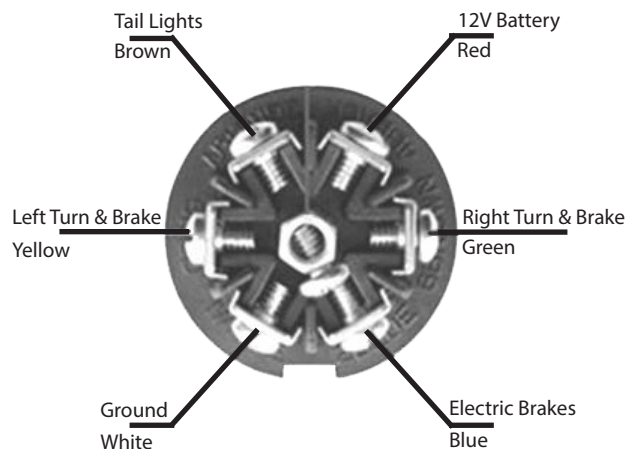
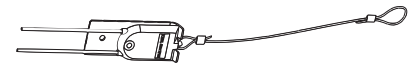

Scale Wiring

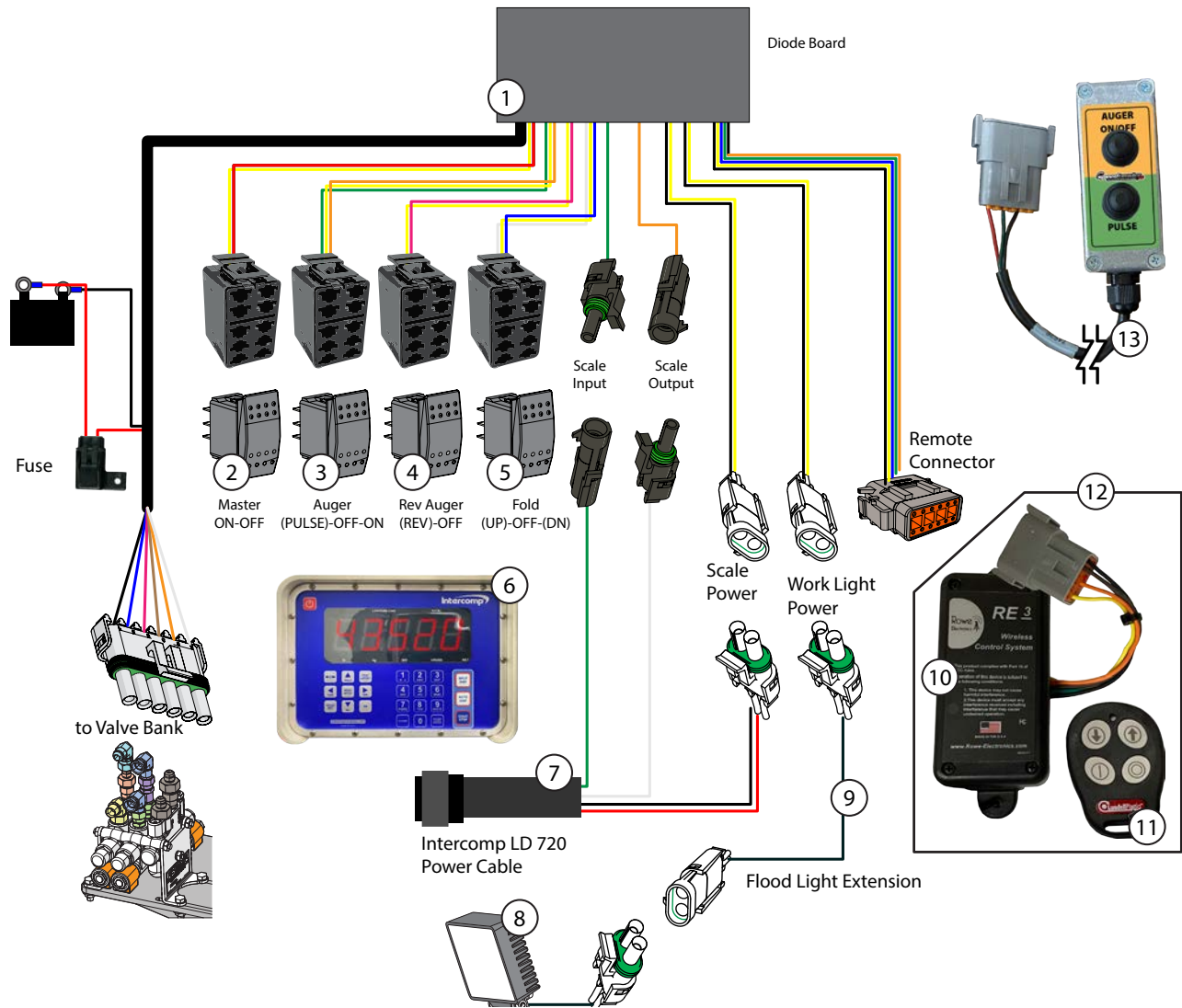

	Description	Part No.
1	51 Series Diode Board Control Harness (PB02)	JM0079625
2	Switch Master ON-OFF (V1D2S00B) 51 Series	JM0076954
3	Switch Auger Fwd (ON)-OFF-ON (V7D2S00B) 51 Series	JM0076916
4	Switch Auger Rev (ON)-OFF (V2D2S00B) 51 Series	JM0076866
5	Switch Auger Fold (ON)-OFF-(ON) (V8D2S00B) 51 Series	JM0076883
6	LD720 Intercomp Scale Indicator	JM0074410
7	Power & Relay Cable for LD720 36"	JM0079397
8	LED Field Light with Weather Pack Connectors (SpeedTender, NitroGro)	JM0050942
9	Auger Light Extension Cable - SpeedTender Pro	JM0029827
10	Rowe Electronics RE3 Wireless Control Receiver	JM0079478
11	Rowe Electronics RE3 Wireless Control Key Fob	JM0079316
12	Lundell Wireless Receiver with Key Fob	JM0051396
13	2 Button 40' Wired Remote (ST)	JM0055261

A-Frame

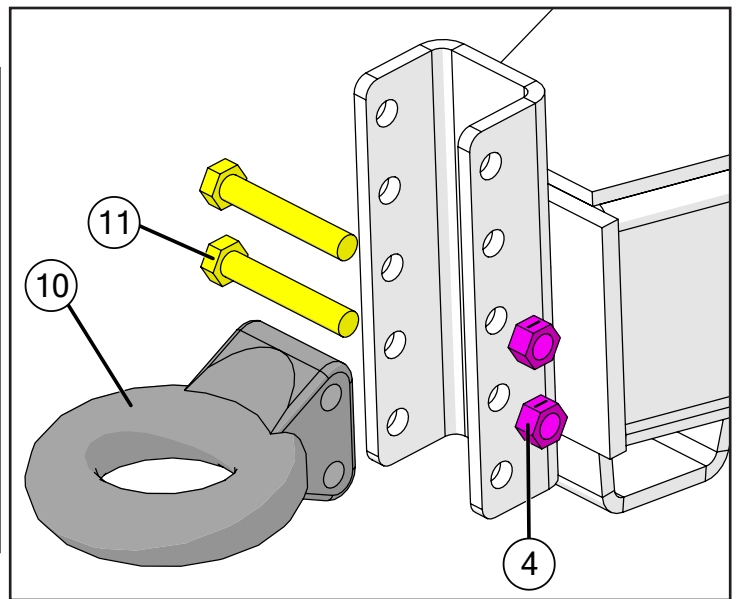
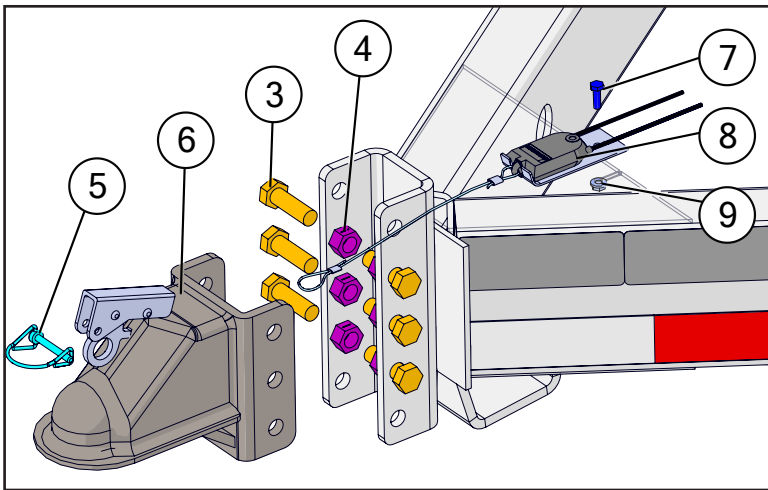
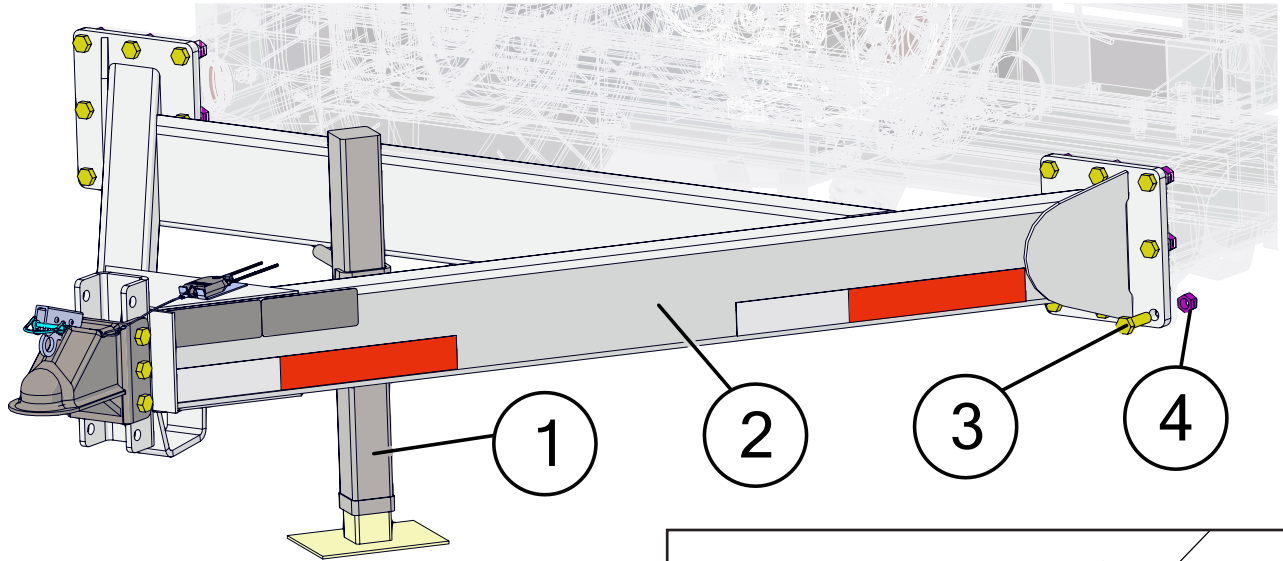

Description	Part No.
1 5,000 lb Max Lift Capacity Jack (TWL-178T)	JM0001480
2 SpeedTender Pro A-Frame Weldment	JM0018547
3 5/8"-11 x 2" Gr8 Z Hex Bolt	JM0001771
4 5/8"-11 Gr2 Z Centerlock Hex Nut	JM0002146
5 1/4" x 1-3/4" Lynch Pin	JM0001478
6 2-5/16" Ball Coupler 21,000lb (BHST375)	JM0001893
7 1/4"-20 x 3/4" Gr5 Z Hex Bolt	JM0001507
8 Breakaway Switch with Cable (BAS-1)	JM0001843
9 1/4"-20 Gr5 Z SF Hex Nut	JM0001630
10 Lunette Eye (30,000# 3" Forged Eye)	JM0015884
11 5/8"-11 x 6" Gr8 Z Hex Bolt	JM0001603
12 12,500 Lb Saftey Chain (SCST375)	JM0015061

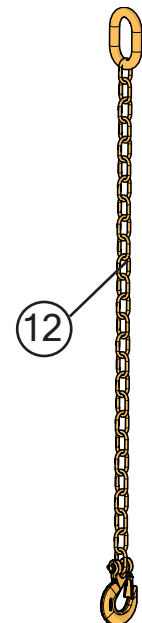

* Two chains for both bumper pull & gooseneck

Gooseneck

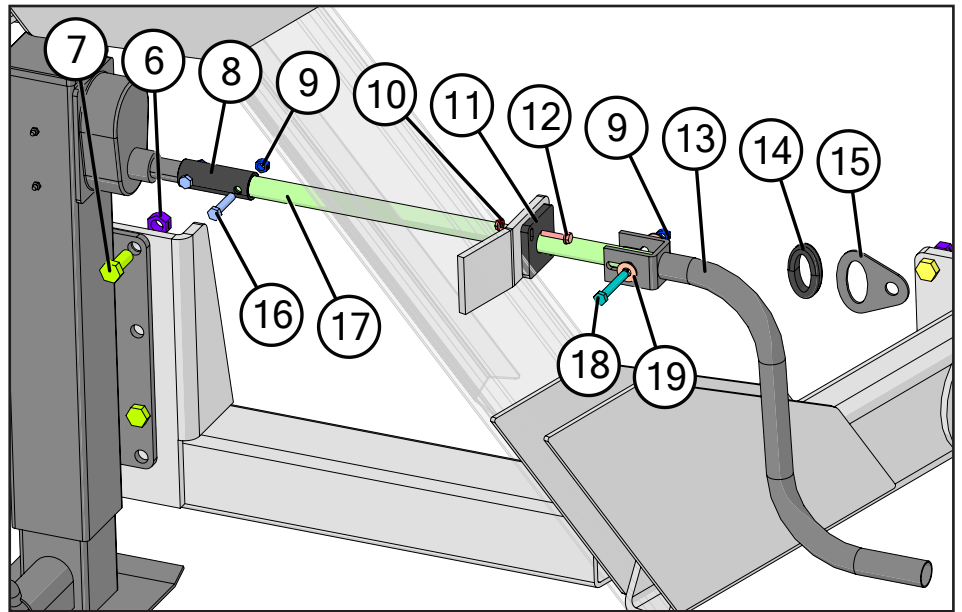
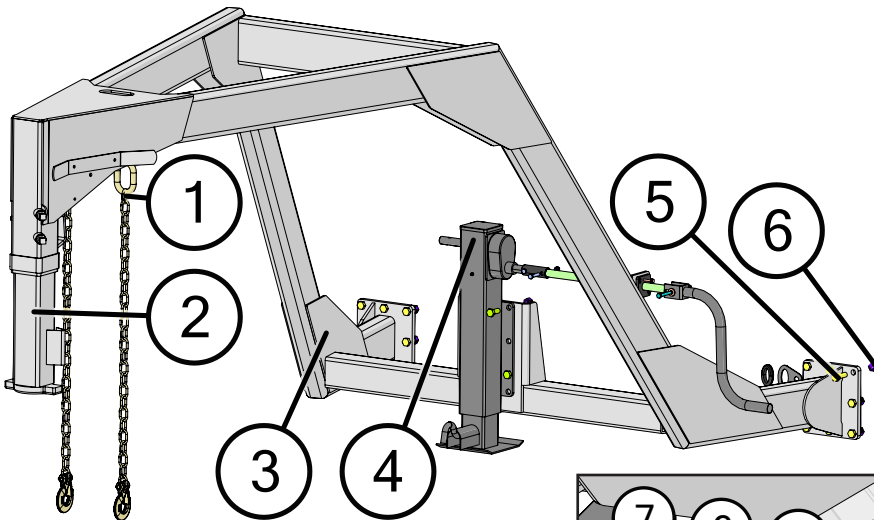

	Description	Part No.
1	12,500 Lb Safety Chain (SCST375)	JM0015061
2	Square Gooseneck Coupler Tube 30,000 LB CAP	JM0007076
3	Gooseneck Frame Weldment for Seed Tenders Less than 500 Seed Units	JM0029497
4	Gooseneck Manual Jack with Custom Mounting Plate (10,000#)	JM0007078
5	5/8"-11 x 2" Gr8 Z Hex Bolt	JM0001771
6	5/8"-11 Gr2 Z Centerlock Hex Nut	JM0002146
7	5/8"-11 x 1-1/2" Gr5 Z Hex Bolt	JM0002103
8	Jack Coupler	JM0029606
9	3/8"-16 Gr2 Z Centerlock Hex Nut	JM0001512
10	1/4"-20 Gr5 Z SF Hex Nut	JM0001630
11	Jack Crank Locator	JM0025756
12	1/4"-20 x 1-1/4" Gr5 Z SF Hex Bolt	JM0001646
13	Gooseneck Jack Handle	JM0007061
14	1-3/4" x 1/4" Oval Grommet (Seed Tender)	JM0007124
15	Wiring Hanger Tab (Seed Tender Chassis)	JM0002346
16	3/8"-16 x 1-3/4" Gr5 Z Hex Bolt	JM0002097
17	Jack Crank Extension Tube	JM0014132
18	3/8"-16 x 2-1/2" Gr5 Z Hex Bolt	JM0001647
19	3/8" USS Flat Washer	JM0003061

Hydraulic Jack

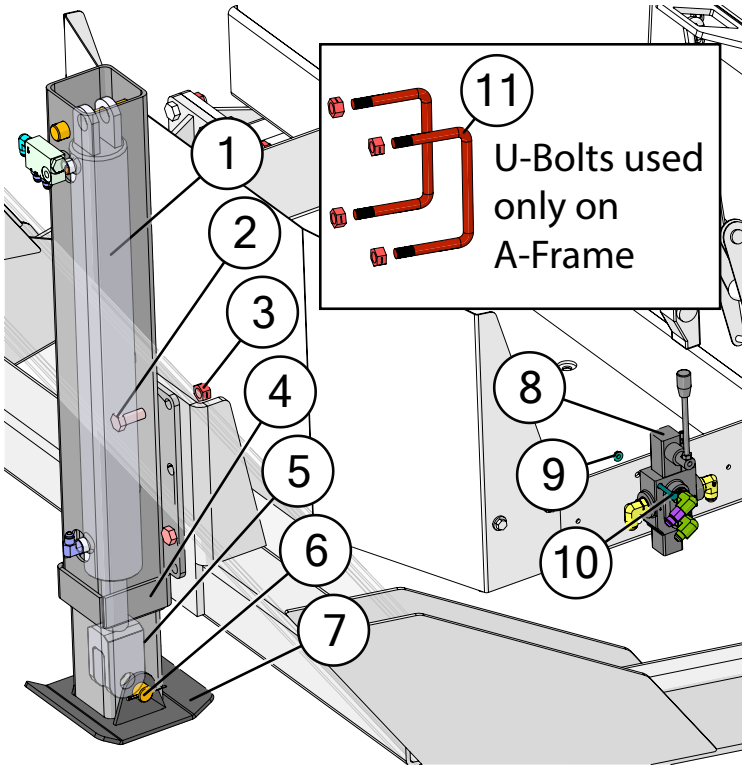

11
U-Bolts used
only on
A-Frame

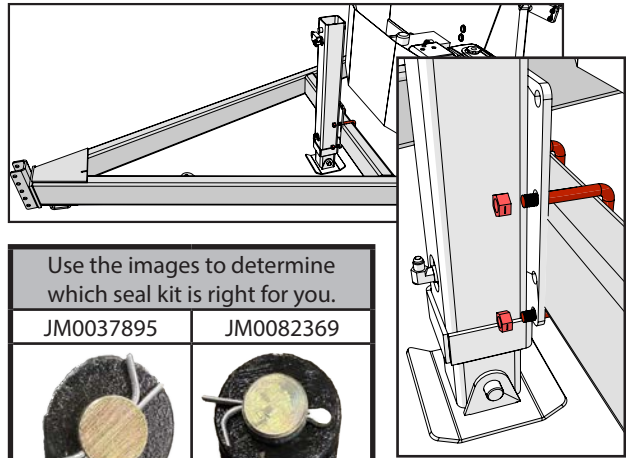

Use the images to determine
which seal kit is right for you.

JM0037895

JM0082369

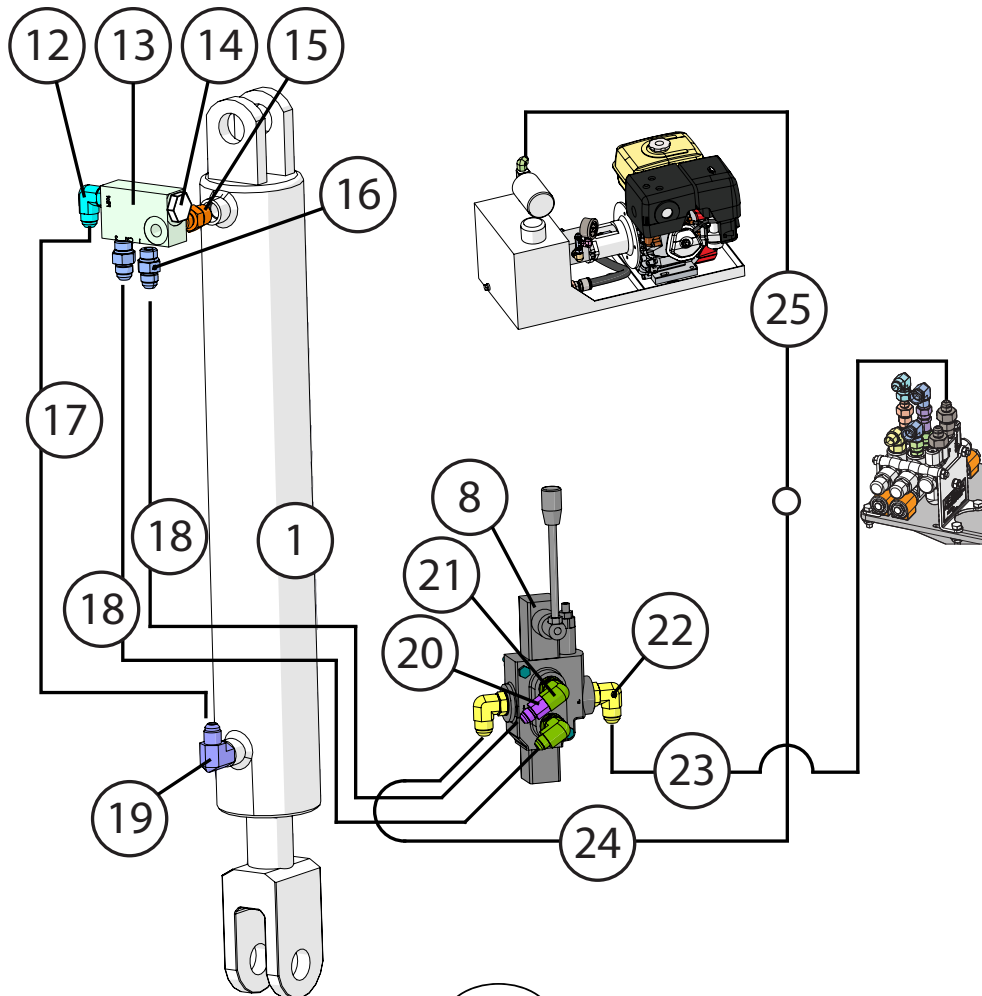

Hydraulic Jack

	Description	Part No.
1	3" x 24" x 1-1/2" Welded Cylinder (JD324)	JM0019644
1	Seal Kit 3" x 24" Cylinder (JD324-1) (JD480)	JM0037895
1	Seal Kit for 3" x 24" Hydraulic Cylinder (30024-SK)	JM0082369
2	5/8"-11 x 1-1/2" Gr5 Z Hex Bolt	JM0002103
3	5/8"-11 Gr2 Z Centerlock Hex Nut	JM0002146
4	Outside Tube Weldment (Hydraulic Jack)	JM0074387
5	4" x 4" x 3/16" Inner Tube (Hydraulic Jack)	JM0061831
6	1" x 6" Pin	JM0031495
7	Foot Pad Weldment (Hydraulic Jack)	JM0074390
8	Hydraulic Jack Hand Valve with Pressure Relief (Youli MB2)	JM0031858
9	1/4"-20 Gr5 Z SF Hex Nut	JM0001630
10	1/4"-20 x 2-1/2" Gr5 Z Hex Bolt	JM0001506
11	5/8"-11 x 6-1/16" x 4-1/16" Square U-Bolt	JM0074246
12	3/8" Male JIC x 3/8" Male ORB; 90 Degree Elbow	JM0026121
13	Serviceable Pilot Check Valve	JM0061684
14	Check Valve Cartridge (CPB25)	JM0074412
15	3/8" Male NPT x 3/8" Male ORB; Straight	JM0061726
16	3/8" Male JIC x 3/8" Male ORB; Straight	JM0043614
17	3/8" x 25" Hydraulic Hose 25inch6M3K-6G-6FJX-6G-6FJX	JM0049162
18	3/8" x 68" Hydraulic Hose 68inch6M3K-6G-6FJX-6G-6FJX	JM0073253
19	3/8" Male NPT x 3/8" Male JIC; 90 Degree Elbow	JM0061728
20	3/8" Male JIC x 3/8" Female JIC with .047 Orifice	JM0054918
21	3/8" Male JIC x 1/2" Male ORB; 90 Degree Elbow	JM0037159
22	1/2" Male JIC x 1/2" Male ORB; 90 Degree Elbow	JM0010297
23	1/2" x 68" Hydraulic Hose 68inch8M3K-8G-8FJX-8G-8FJX	JM0073262
24	1/2" x 34" Hydraulic Hose 34inch8M3K-8G-8MJX-8G-8FJX	JM0073263
25	1/2" x 34" Hydraulic Hose 34inch8M3k-8G-8FJX-8G-8FJX	JM0025347



Talc Hydraulics Schematic

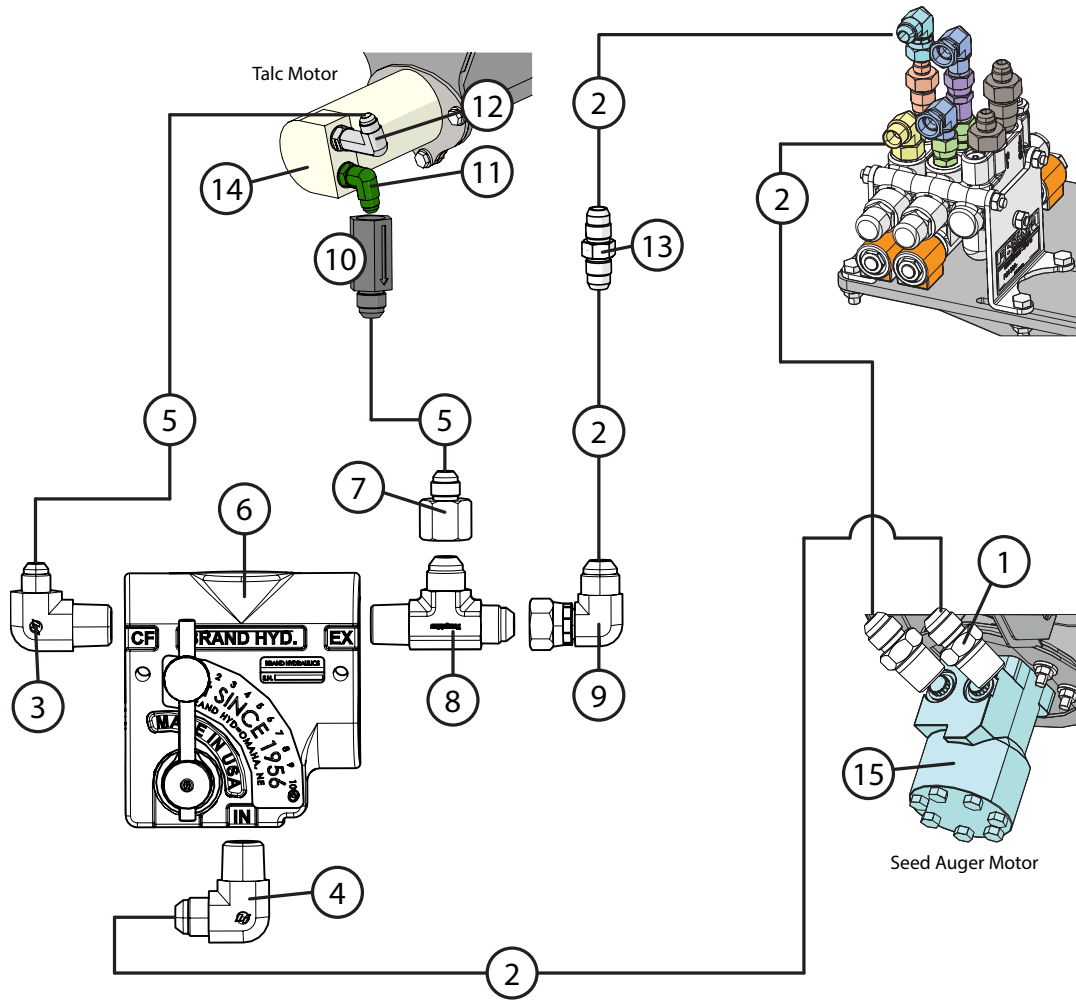

Description	Part No.
1 1/2" Male JIC x 1/2" Male NPT; Straight	JM0015201
2 1/2" x 70" Hydraulic Hose 70inch8M3K-8G-8FJX-8G-8FJX	JM0079328
3 3/8" Male JIC x 1/2" Male NPT; 90 Degree Elbow	JM0042849
4 1/2" Male JIC x 1/2" Male NPT; 90 Degree Elbow	JM0042847
5 1/4" x 194" Hydraulic Hose 194inch4M3k-4G-6MP-4G-6FJX	JM0041444
6 Flow Control Talc Applicator FC51 - .5 (0-2 GPM)	JM0026104
7 1/2" Female JIC x 3/8" Male JIC Reducer	JM0026117
8 1/2" Male JIC x 1/2" Male NPT x 1/2" Male JIC Tee	JM0026119
9 1/2" Male JIC x 1/2" Female JIC Swivel; 90 Degree Elbow (6500-08-08)	JM0010296
10 Vonberg - 1906FF Poppet Style Check Valve	JM0086460
11 3/8" Male JIC x 3/8" Male ORB; 90 Degree Elbow	JM0026121
12 3/8" Male JIC x 3/8" Male ORB; Extra Long 90 Degree Elbow	JM0039050
13 1/2" Male JIC x 1/2" Male JIC; Straight	JM0041452
14 White Drive Hydraulic Motor - 125032JL5C3AAAAA	JM0042491
15 WR Series Hydraulic Motor with Keyway and Pinhole (15100F30N6AAAAA)	JM0010469

Hydraulic Motor Assembly 2024 - Current

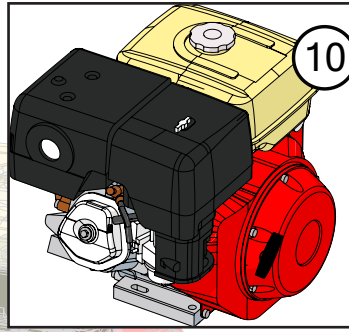
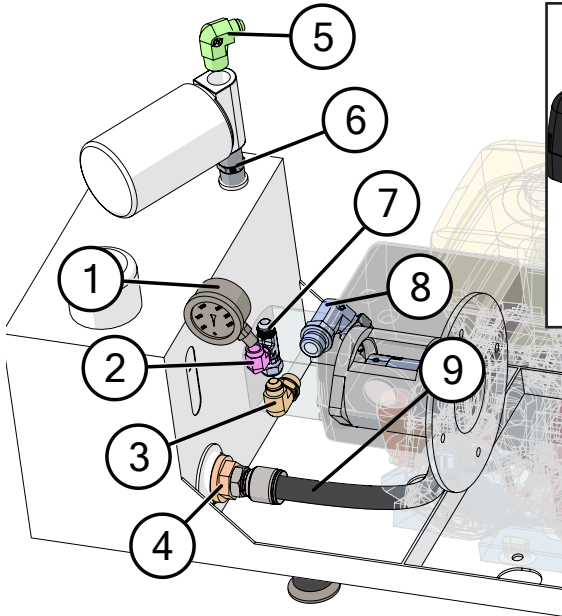

	Description	Part No.
1	Pressure Gauge 0-3000 PSI (P562713)	JM0037742
2	#4 Male SAE ORB x 1/4" Female Pipe 90 Deg Elbow	JM0085124
3	1/2" Male JIC x 5/8" Male ORB; 90 Degree Elbow	JM0039215
4	LENZ Tank Hydraulic Oil Screen (LTMA-10-100)	JM0084748
5	1/2" Male JIC x 3/4" Male NPT; 90 Degree Elbow	JM0033775
6	3/4" Nipple	JM0010137
7	#8 Female JIC X #8 Male JIC X #4 Gauge Port - Tee	JM0085121
8	#12 Male NPT x #12 Female JIC Swivel - Extra Long Elbow	JM0084903
9	3/4" x 18" Crimped Hydraulic Hose - 18inch12CR2-12G-12MORB-12G-12FJX	JM0084751
10	Honda GX390 Engine	JM0001749

Hydraulic Motor Assembly 2024 - Older

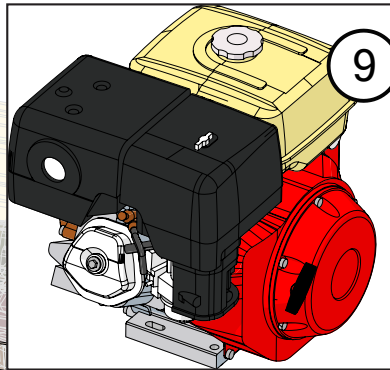
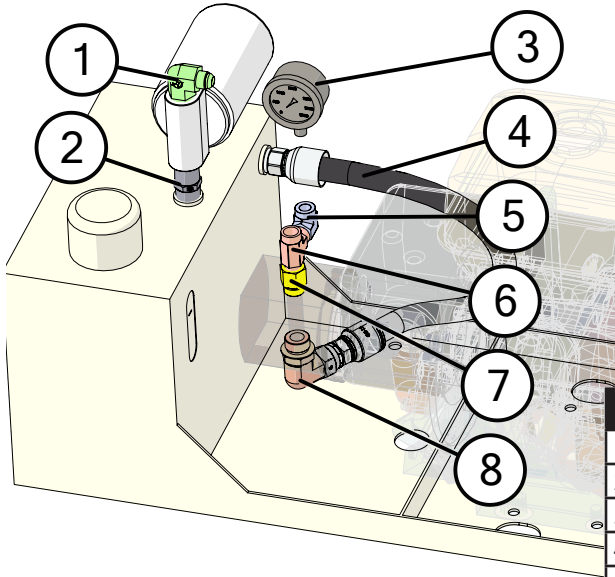

	Description	Part No.
1	1/2" Male JIC x 3/4" Male NPT; 90 Degree Elbow	JM0033775
2	3/4" Nipple	JM0010137
3	Pressure Gauge 0-3000 PSI (P562713)	JM0037742
4	3/4" x 18" Crimped Hydraulic Hose - 18inch12CR2-12G-12MP-12G-12FJX	JM0086698
5	#6 Male NPT x #4 Female NPT - Elbow	JM0037487
6	3/8" Male NPT x 3/8" Female NPT x 3/8" Female NPT; Street T	JM0018266
7	#10 Male ORB x #6 Female NPT - Straight	JM0037488
8	#12 Male JIC x #12 ORB Male - Elbow (6801-12-12)	JM0037489
9	Honda GX390 Engine	JM0001749

Hydraulics Schematic

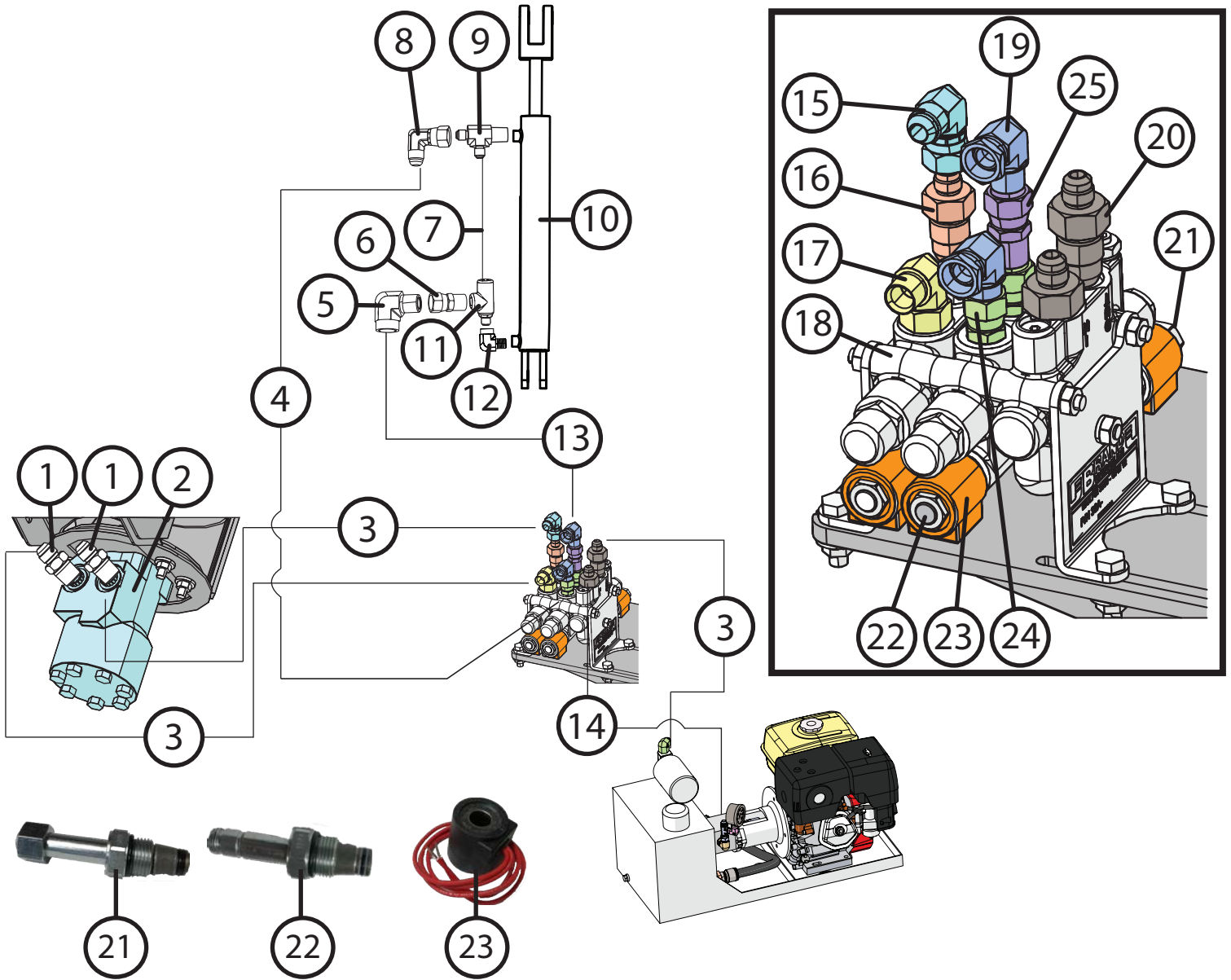

Hydraulic Schematic

	Description	Part No.
1	1/2" Male JIC x 1/2" Male NPT; Straight	JM0015201
2	WR Series Hydraulic Motor with Keyway and Pinhole (15100F30N6AAAAA)	JM0010469
2	Seal Kit for 15100F30N6AAAAA WR Series Hydraulic Motor	JM0042773
3	1/2" x 34" Hydraulic Hose 34inch8M3k-8G-8FJX-8G-8FJX	JM0025347
4	1/4" x 102" Hydraulic Hose 102inch4IA3k-4G-6MP-4G-6FJX	JM0081669
5	3/8" Male NPT x 3/8" Female NPT; 90 Degree Elbow	JM0030059
6	3/8" Male x 3/8" Female Swivel; Straight .032 Orifice	JM0019899
7	1/4" x 12" Hydraulic Hose 12inch4M3k-4G-4MP-4G-6FJX	JM0010282
8	3/8" Male JIC x 3/8" Female JIC Swivel; 90 Degree Elbow	JM0010295
9	3/8" Male JIC x 1/2" Male NPT x 3/8" Male JIC; Tee	JM0010291
10	2" x 12" Hydraulic Cylinder with 1-1/8" Shaft	JM0025341
10	Seal Kit for 2" Red Lion Hydraulic Cylinder (RK20TR-112)	JM0026606
11	PC-37 Check Valve	JM0018233
12	3/8" Female NPT x 1/2" Male NPT; 90 Degree Elbow	JM0010292
13	1/4" x 90" Hydraulic Hose 90inch4IA3k-4G-6MP-4G-6MPX	JM0081668
14	1/2" x 34" Hydraulic Hose 34inch8M3k-8G-8FJX-8G-8FJX	JM0025347
15	1/2" Male JIC x 1/2" Female JIC Swivel; 90 Degree Elbow (6500-08-08)	JM0010296
16	1/2" Male JIC x 1/2" Male O-ring; Straight	JM0010293
17	1/2" Male JIC x 1/2" Male ORB; 90 Degree Elbow	JM0010297
18	2 Spool Valve Body	JM0001829
19	3/8" Male NPT x 3/8" Female NPT Swivel; 90 Degree Elbow with .062 Orifice	JM0010299
20	1/2" Male JIC x 5/8" Male O-Ring; Straight	JM0010294
21	Brand Valve Large Cartridge (SV08-1616) 3-1/4" Length	JM0020840
22	Brand Valve Small Cartridge (SV10-1512) 3" Length	JM0020841
23	Replacement Solenoid Sleeve (6302012) (SL-2)	JM0037164
24	1/2" Male ORB x 3/8" Female NPSM Swivel; Straight	JM0010298
25	3/8" Male NPT x 3/8" Female NPT Swivel; Straight	JM0010288



Seed Box Frame

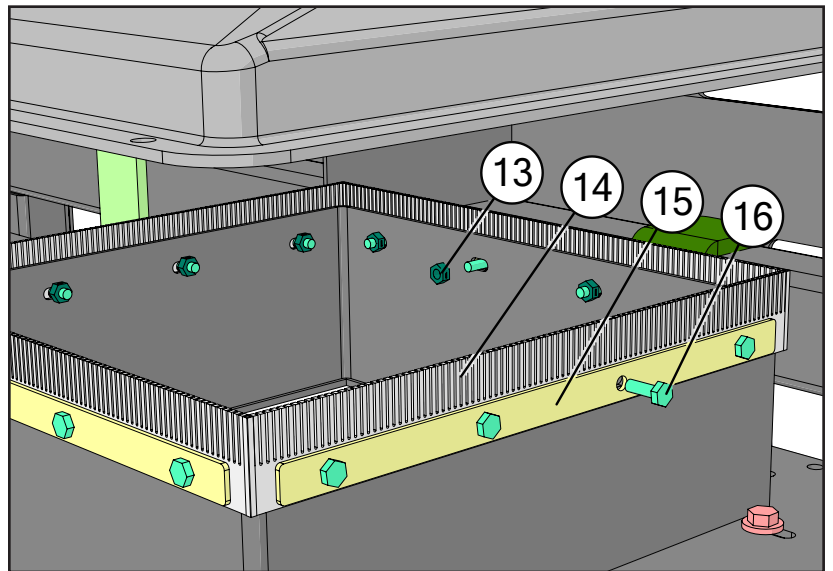
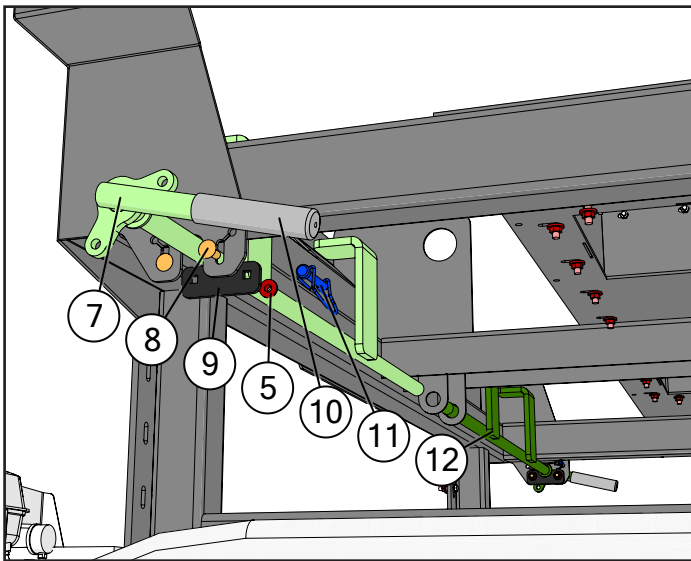
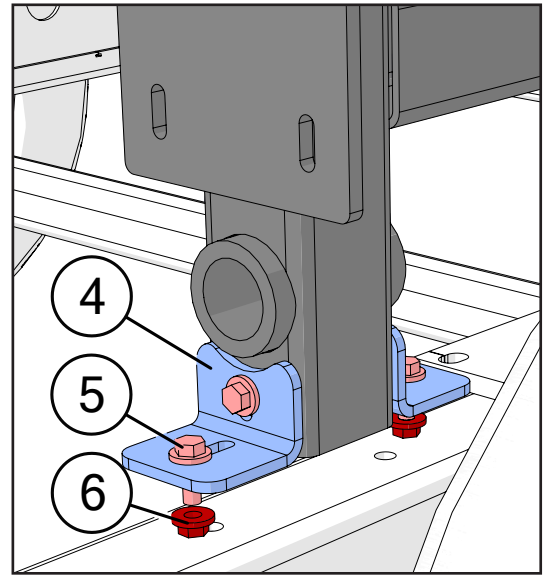
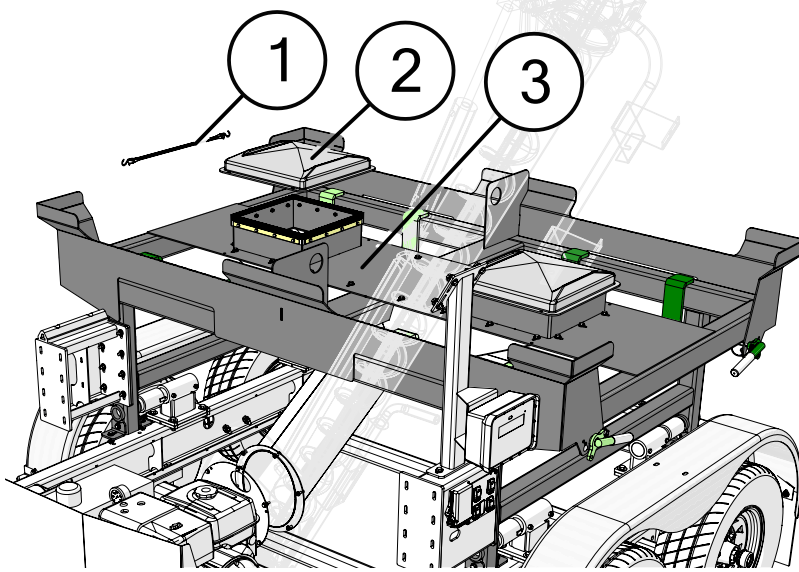

	Description	Part No.
1	21" Rubber Bungie Strap	JM0079474
2	SpeedTender Pro Plastic Lid	JM0025520
3	Frame Assembly SpeedPro 200	JM0068627
4	Bolt On Foot Pad	JM0077674
5	3/8"-16 x 1" Gr5 Z SF Hex Bolt	JM0002092
6	3/8"-16 Gr5 Z SF Hex Nut	JM0002152
7	Left Lock Weldment (251, 451)	JM0079747
8	SpeedTender Pro Lock Down Bolt-on Plate	JM0020505
9	3/8"-16 x 1" Gr5 Z Carriage Bolt	JM0001632
10	1" ID x 6" Black Slide on Round Grip (6BSR)	JM0024290
11	3/8" x 2-1/2" Wire Lock Pin (38212WLP)	JM0014929
12	Right Lock Weldment (251, 451)	JM0079748
13	1/4"-20 Gr2 Z Centerlock Hex Nut	JM0001505
14	1/8" Rubber Brush for SpeedTender Pro Chute	JM0027580
15	Top Inside Ring for Chute (SpeedTender Pro)	JM0027579
16	1/4"-20 x 3/4" Gr5 Z Hex Bolt	JM0001507



Chutes

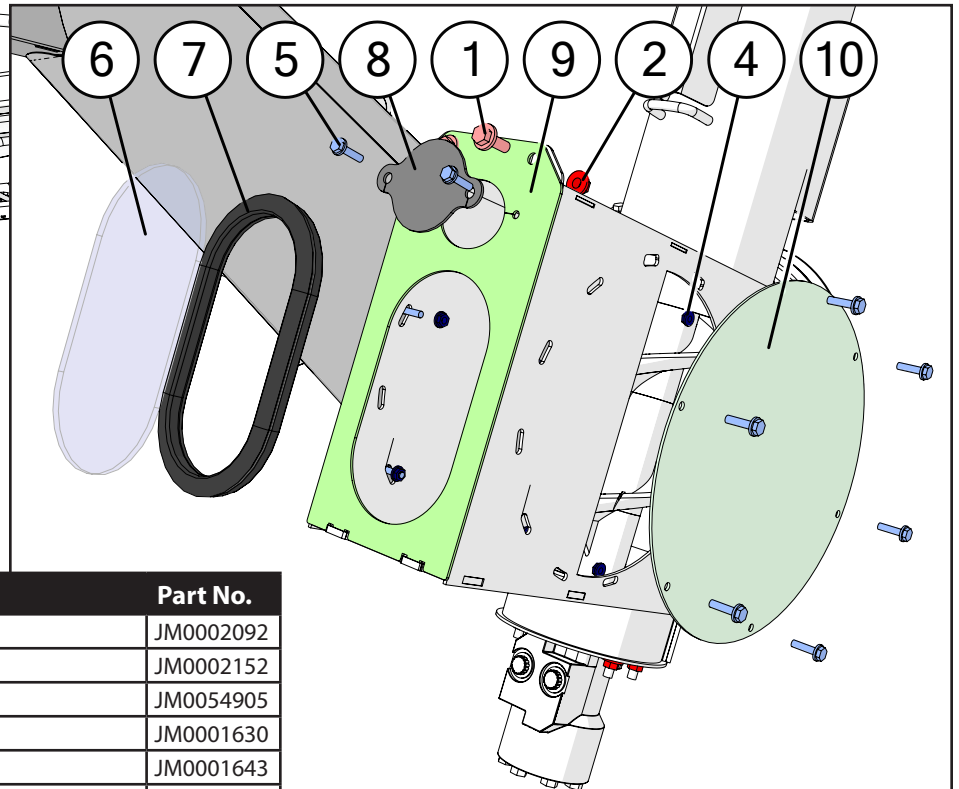
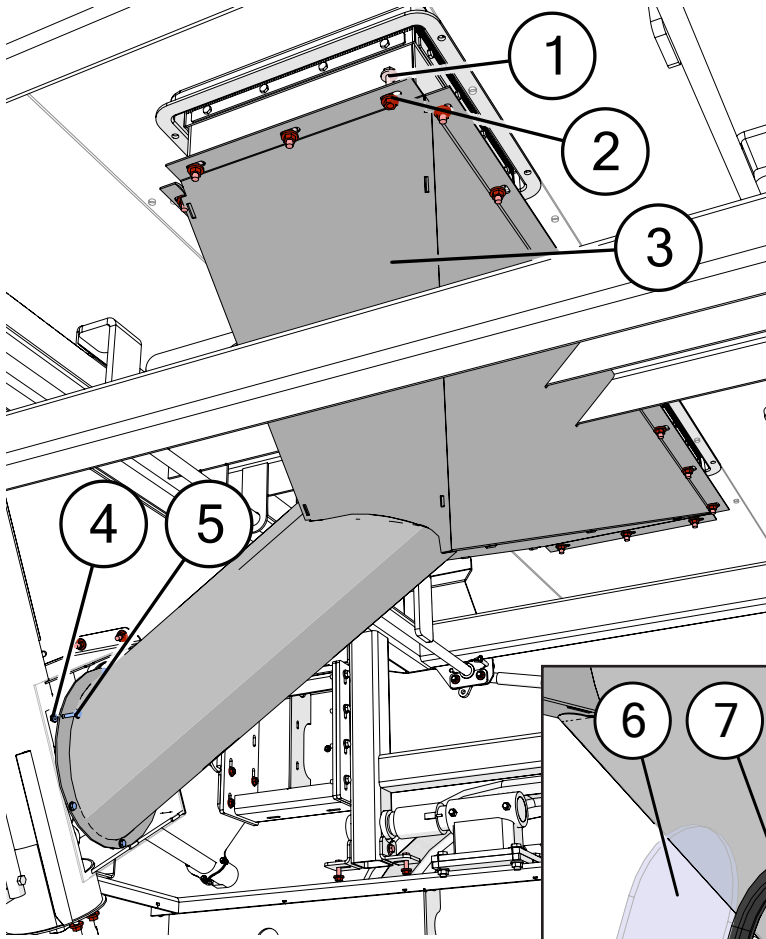

Description	Part No.
1 3/8"-16 x 1" Gr5 Z SF Hex Bolt	JM0002092
2 3/8"-16 Gr5 Z SF Hex Nut	JM0002152
3 51 Series Hopper Chute	JM0054905
4 1/4"-20 Gr5 Z SF Hex Nut	JM0001630
5 1/4"-20 x 1" Gr5 Z SF Hex Bolt	JM0001643
6 LC290 Small Top Oval Window	JM0040603
7 LC290 Small Top Window Grommet	JM0040606
8 Talc Hole Cover	JM0024959
9 Auger Door with Window and Talc Hole, 51 Series	JM0058413
10 Hopper Chute Cap, 251	JM0058364

Chassis

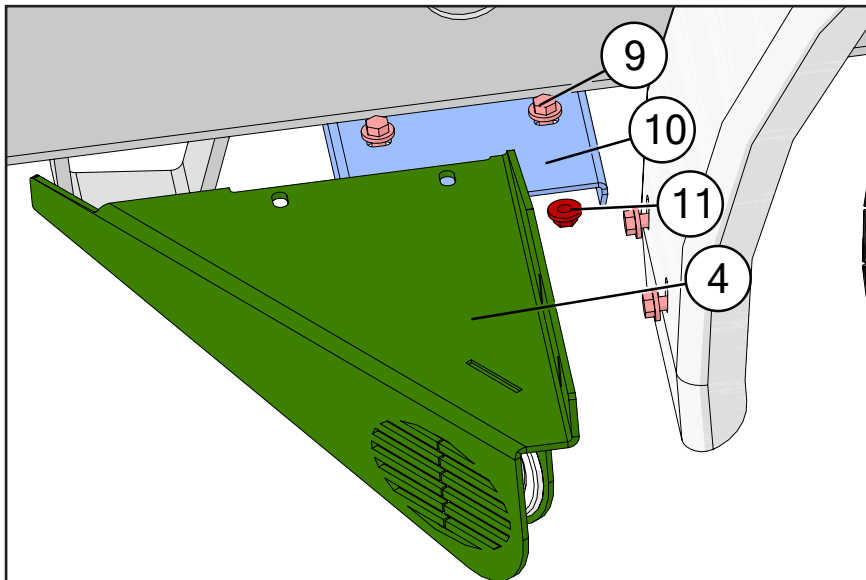
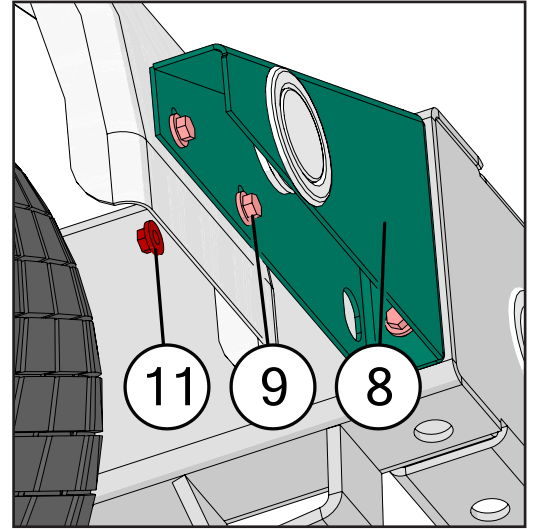
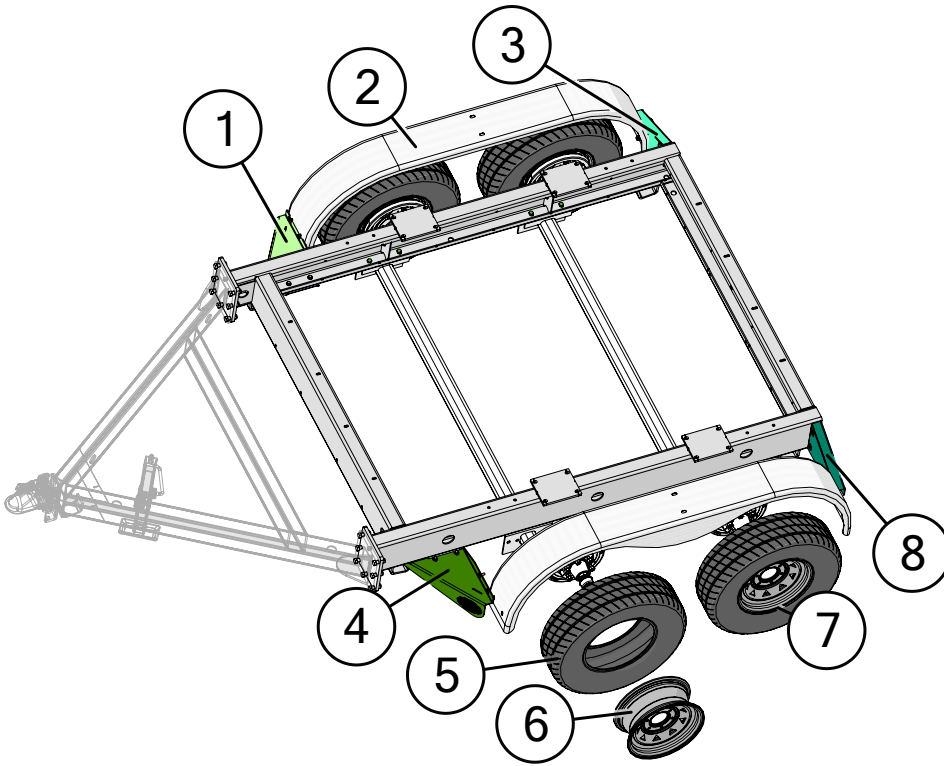

Description	Part No.
1 Passenger Side Front Fender Bracket	JM0068794
2 2-Wheel Fender (72-1/2" Length) (WF-1)	JM0030412
3 Passenger Side Rear Fender Bracket, 51 Series	JM0058120
4 Driver Side Front Fender Bracket	JM0068793
5 ST225/75D15 Load Range D - 6 Bolt Tire	JM0032197
6 Wheel Rim, 6 hole, 15" x 6" (15x6-6)	JM0032195
7 Wheel & Tire (ST225/75D15 Load Range D - 6 Bolt Tire and 15x6-6 Hole Wheel Rim)	JM0032198
8 Driver Side Rear Fender Bracket, 51 Series	JM0058106
9 3/8"-16 x 1" Gr5 Z SF Hex Bolt	JM0002092
10 Plate - Bolt on Fender Mounts (7" x 7-1/2")	JM0054929
11 3/8"-16 Gr5 Z SF Hex Nut	JM0002152



Motor Mount

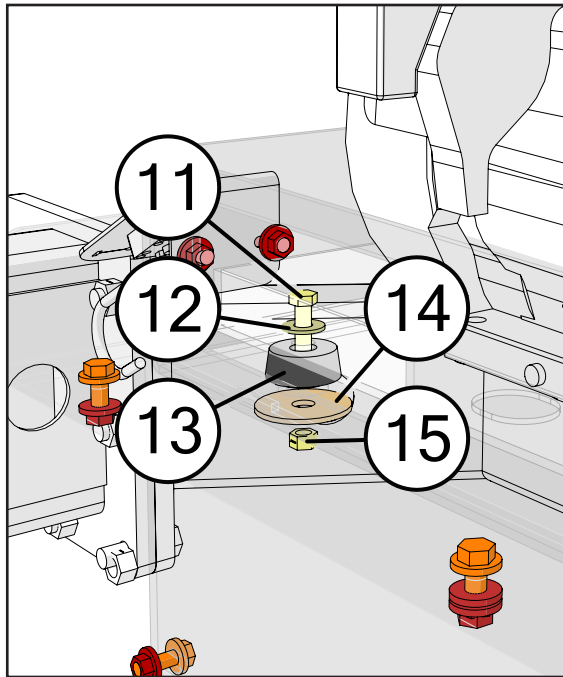
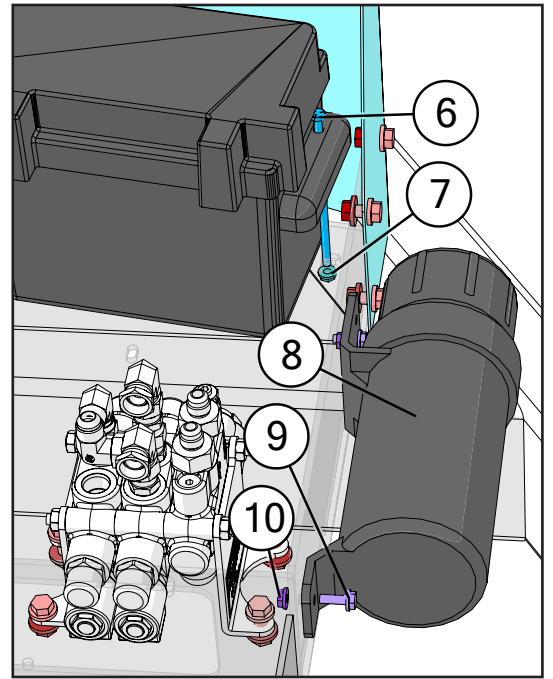
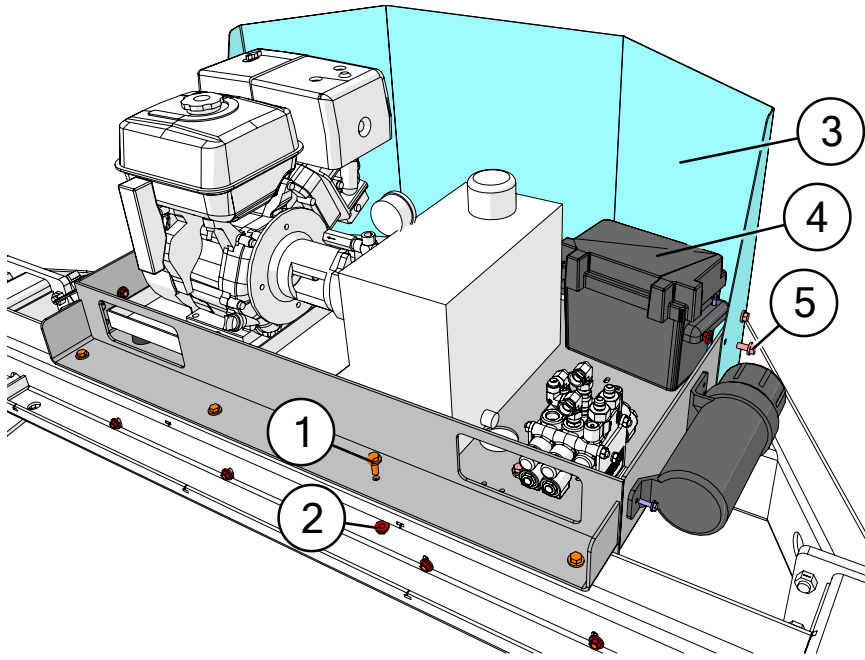

Description	Part No.
1 3/8"-16 x 1" Gr5 Z SF Hex Bolt	JM0002092
2 3/8"-16 Gr5 Z SF Hex Nut	JM0002152
3 Engine Cover (Seed Tender) (ECST375)	JM0000327
4 Battery Box (SpeedTender)	JM0001846
5 3/8"-16 x 3/4" Gr5 Z SF Hex Bolt	JM0001750
6 1/4"-20 x 6" Gr5 Z Hex Bolt	JM0049441
7 1/4"-20 Gr5 Z SF Hex Nut	JM0001630
8 Manual Canister 4-1/4" Diameter	JM0025266
9 1/4"-20 x 3/4" Gr5 Z SF Hex Bolt	JM0001642
10 1/4"-20 Gr5 Z Flange Nut	JM0001499
11 3/8"-16 x 2" Gr5 Z Hex Bolt	JM0001510
12 3/8" USS Flat Washer	JM0003061
13 Neoprene Vibration Damping Mount with 5/8" Diameter Hole	JM0001869
14 1/2" ID x 2-1/4" OD Flat Washer - 1/8" Thick	JM0019081
15 3/8"-16 Gr2 Z Centerlock Hex Nut	JM0001512

Axle Attachment

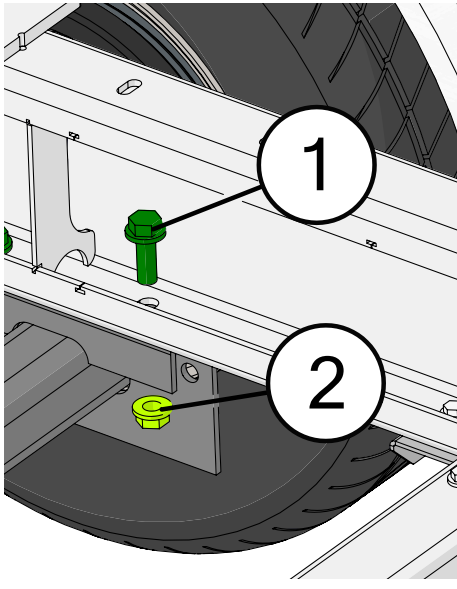

	Description	Part No.
1	5/8"-11 x 1-3/4" Gr5 Z SF Hex Bolt	JM0027674
2	5/8"-11 Gr5 Z SF Hex Nut	JM0002151

Scale Bar Mount

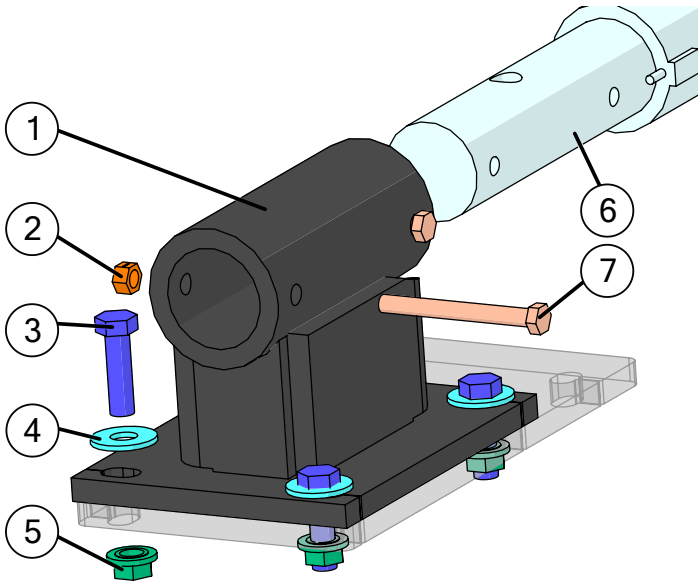

	Description	Part No.
1	Seed Tender Scale Mount Weldment (SMST4W)	JM0009966
2	3/8"-16 Gr2 Z Centerlock Hex Nut	JM0001512
3	1/2"-13 x 1-3/4" Gr5 Z Hex Bolt	JM0002101
4	1/2" ID, 1-3/8" OD Z Flat Washer	JM0003082
5	1/2"-13 Gr5 Z SF Hex Nut	JM0002153
6	Intercomp 2-1/8" Weigh Bar	JM0041719
7	3/8"-16 x 3-1/2" Gr5 Z Hex Bolt	JM0001986

Battery Disconnect

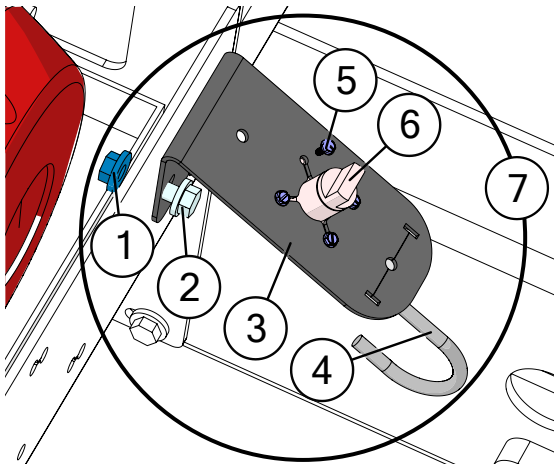

	Description	Part No.
1	3/8"-16 Gr5 Z SF Hex Nut	JM0002152
2	3/8"-16 x 3/4" Gr5 Z SF Hex Bolt	JM0001750
3	Battery Disconnect Bracket, 51 Series	JM0054525
4	Battery Disconnect Cable (96")	JM0054583
5	#6 x 5/8" Slotted Hex Head Screw	JM0079210
6	Battery Disconnect Switch	JM0053441
7	Battery Disconnect Assembly, 51 Series	JM0054581

Brakes and Hub Assembly

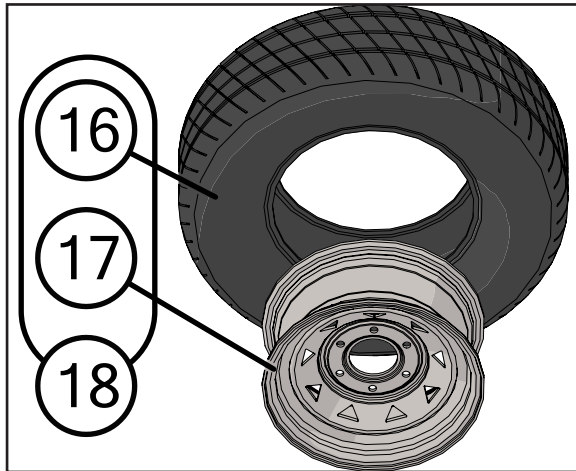
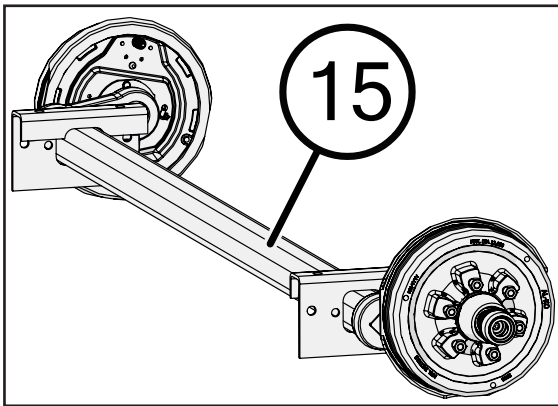
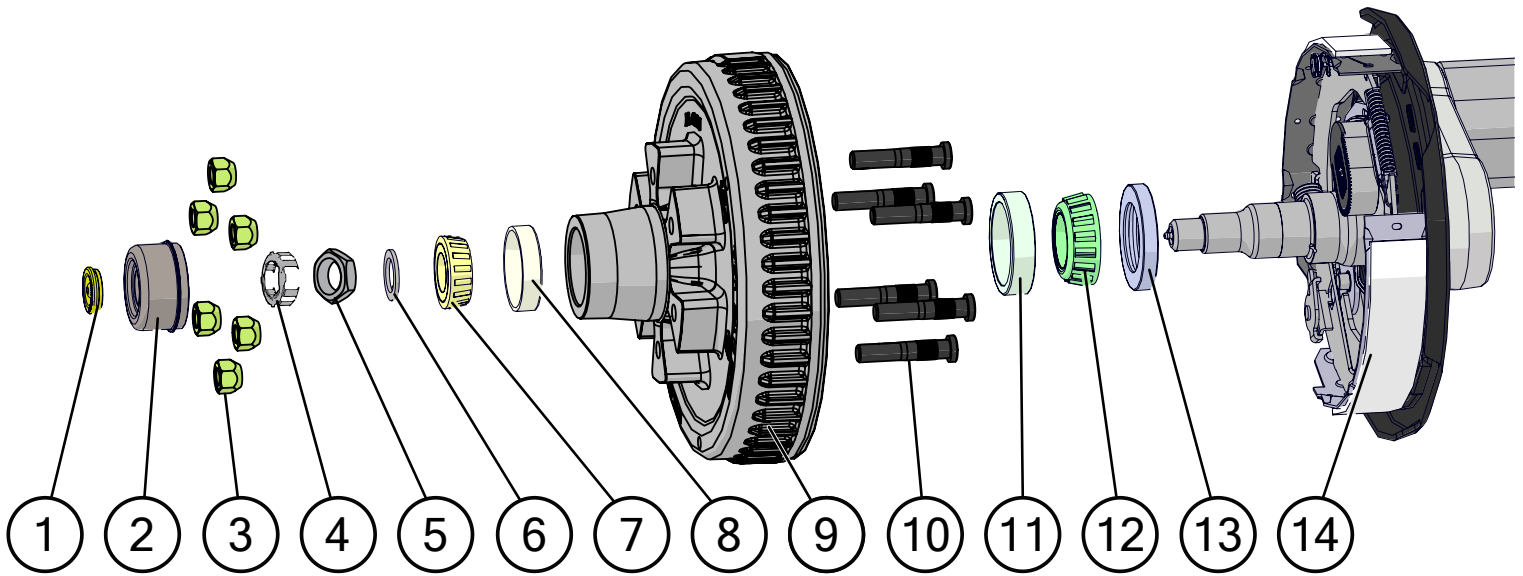

Description	Part No.
1 Rubber Plug for Dust Cap	JM0039538
2 Dust Cap for EZ Grease (5,200lb)	JM0039577
3 1/2"-20 Lug Nut, 6-8 Ton (5552)	JM0003062
4 Spring Steel Retaining Clip (7k)	JM0051458
5 Special 1" Jam Nut for 5.2k, 7k Axles	JM0035955
6 D Washer (1" ID)	JM0039578
7 Bearing Cone (15123)	JM0019551
8 Race, Outer 15245 (5.2k axle)	JM0019548
9 Hub Drum with Studs and Races For 5.2K Axle	JM0039575
10 1/2"-20 x 2-13/20" Stud	JM0039598
11 Cup, Large Inner, 12 Ton, 25520	JM0018102
12 Tapered Bearing Cone 25580, 12 Ton	JM0018104
13 2-1/4" ID Grease Seal (010-036-00)	JM0035951
14 7K Brake Drum Assembly Right Hand	JM0035974
14 7K Brake Drum Assembly Left Hand	JM0035973
15 5,200 lb. Axle with Brakes	JM0039549
16 ST225/75D15 Load Range D - 6 Bolt Tire	JM0032197
17 Wheel Rim, 6 hole, 15" x 6" (15x6-6)	JM0032195
18 Wheel & Tire (ST225/75D15 Load Range D - 6 Bolt Tire and 15x6-6 Hole Wheel Rim)	JM0032198

Auger

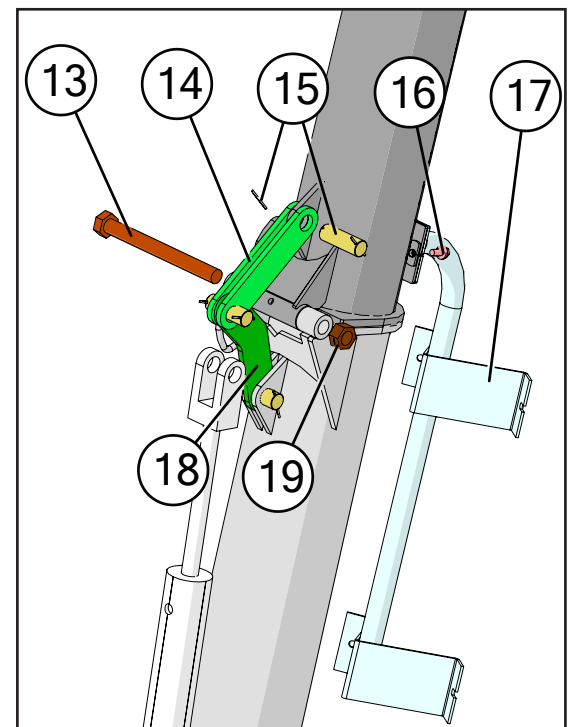
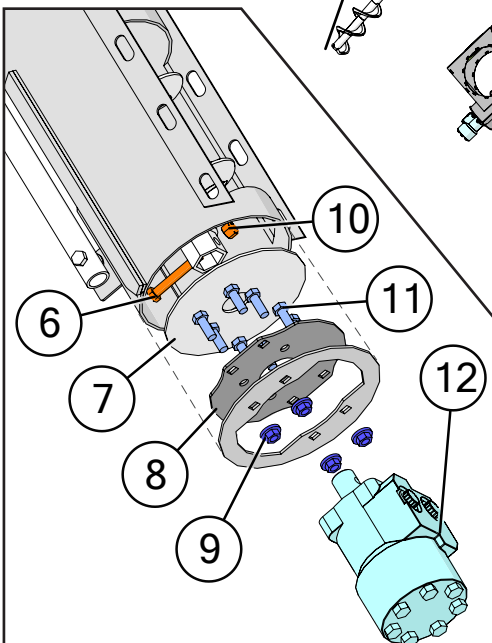
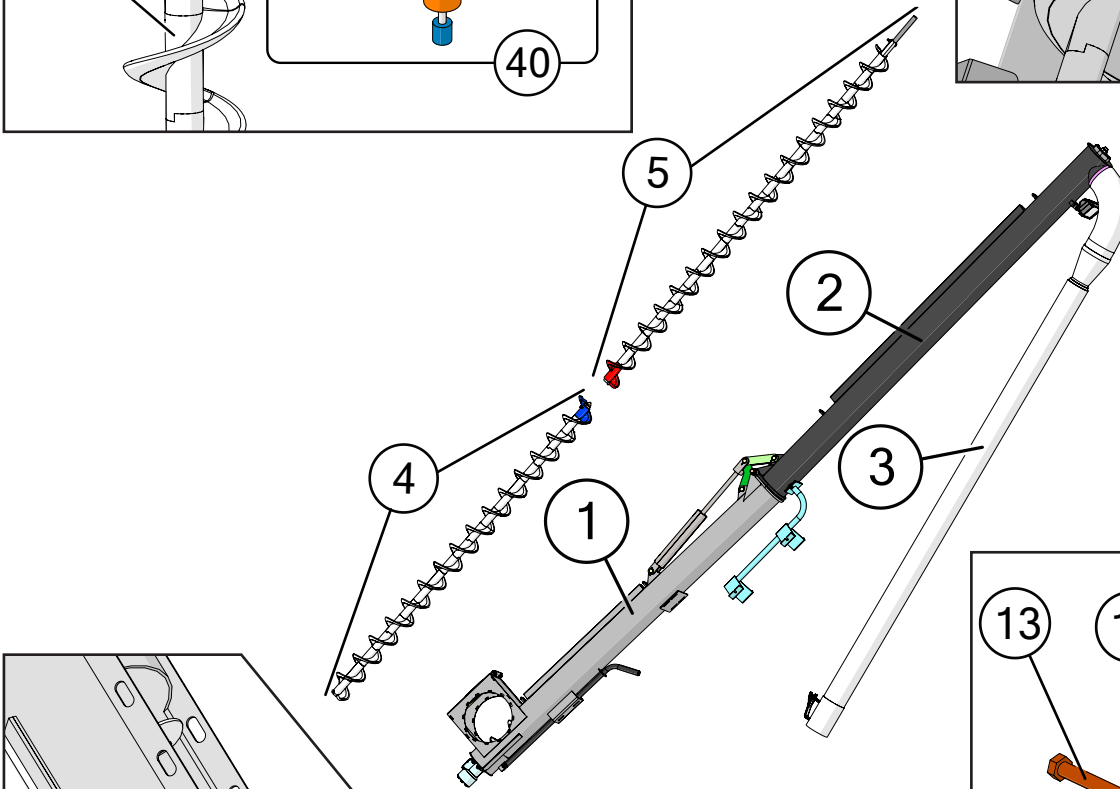
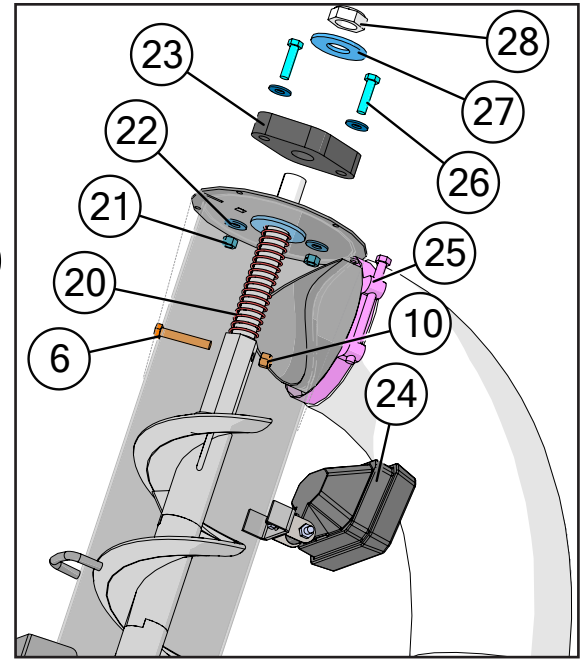
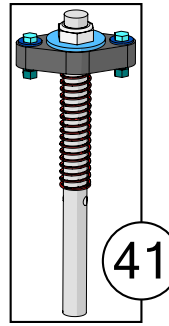
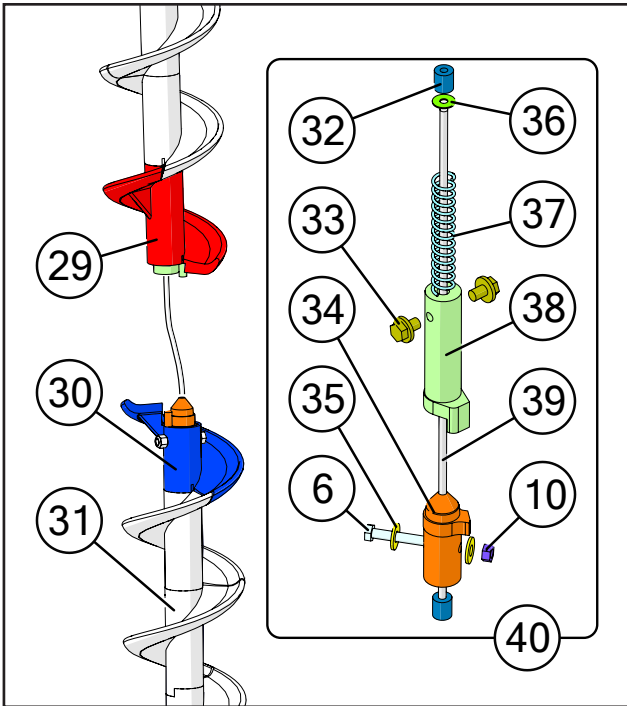

Auger

	Description	Part No.
1	Bottom Auger Weldment (251, 451)	JM0055199
2	Top Auger Weldment (251, 451)	JM0058180
3	19' Telescoping Spout (6" Diameter)	JM0021785
4	SpeedTender Pro Lower Auger Assembly	JM0018343
5	SpeedTender Pro Upper Auger Assembly	JM0018344
6	5/16"-18 x 2-1/2" Gr5 Z Hex Bolt	JM0028310
7	Auger Washer (SpeedTender Pro)	JM0028342
8	Auger Motor Bolt Plate (SpeedTender Pro)	JM0018154
9	3/8"-16 Gr5 Z SF Hex Nut	JM0002152
10	5/16"-18 Gr2 Z Centerlock Hex Nut	JM0002143
11	3/8"-16 x 1" Gr5 Z Hex Bolt	JM0001592
12	WR Series Hydraulic Motor with Keyway and Pinhole (15100F30N6AAAAA)	JM0010469
12	Seal Kit for 15100F30N6AAAAA WR Series Hydraulic Motor	JM0042773
13	7/8"-9 x 9" Gr8 Z Hex Bolt	JM0024283
14	Upper Linkage Bar (SpeedTender Pro)	JM0019805
15	1" x 3" Clevis Pin with Cotter Pins	JM0019407
16	3/8"-16 x 3/4" Gr5 Z Hex Bolt	JM0001663
17	SpeedTender Pro Auger Down Spout Clamp Weldment	JM0020580
18	Lower Linkage Bar for SpeedTender Pro (1" Holes, 5-11/16" Between Holes)	JM0016510
19	7/8"-9 Gr2 Z Centerlock Hex Nut	JM0002148
20	1-1/8" ID, 3/32" Diameter Wire, 6" Long Compression Spring	JM0032536
21	3/8"-16 Gr2 Z Centerlock Hex Nut	JM0001512
22	3/8" USS Flat Washer	JM0003061
23	UHMW Black UV Bearing - SpeedTender Pro	JM0029438
24	LED Field Light with Weather Pack Connectors (SpeedTender, NitroGro)	JM0050942
25	6" Diameter Spout Clamp (HC-6)	JM0028349
26	3/8"-16 x 1-1/2" Gr5 Z Hex Bolt	JM0001659
27	1" USS Flat Washer	JM0003063
28	1"-8 Gr5 Z Nylon Locking Hex Jam Nut	JM0032539
29	6" x 5-1/2" Cupped Plastic Flighting with Brace - Bottom of Top	JM0032529
30	6" x 5-1/2" Cupped Plastic Flighting with Brace - Top of Bottom	JM0032530
31	6" x 5-1/2" Cupped Plastic Flighting Section	JM0018339
32	Aluminum Stop for 1/4" Cable	JM0040145
33	3/8"-16 x 1/2" Gr5 Z SF Hex Bolt	JM0040150
34	Short Pro Box Bullet Nose	JM0076271
35	5/16" USS Flat Washer (7/8" OD)	JM0001742
36	M6 Flat Washer	JM0019447
37	4-1/2" Compression Spring (CMSUAA-4)	JM0018559
38	Long Bullet Nose Pro-Box	JM0076270
39	1/4" x 19" Cable (SpeedTender Pro)	JM0040143
40	SpeedTender Pro Auger Cable Complete Assembly	JM0040147
41	Pro Box Upper Auger Shaft, Spring & Bearing Assembly	JM0080198



Auger Prop and Rest

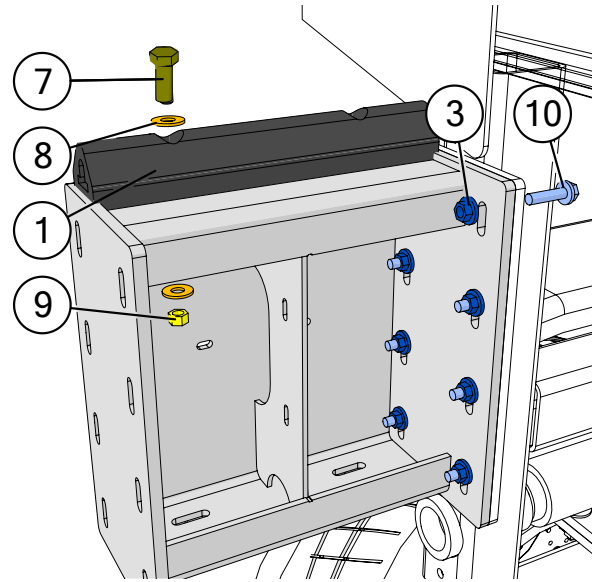
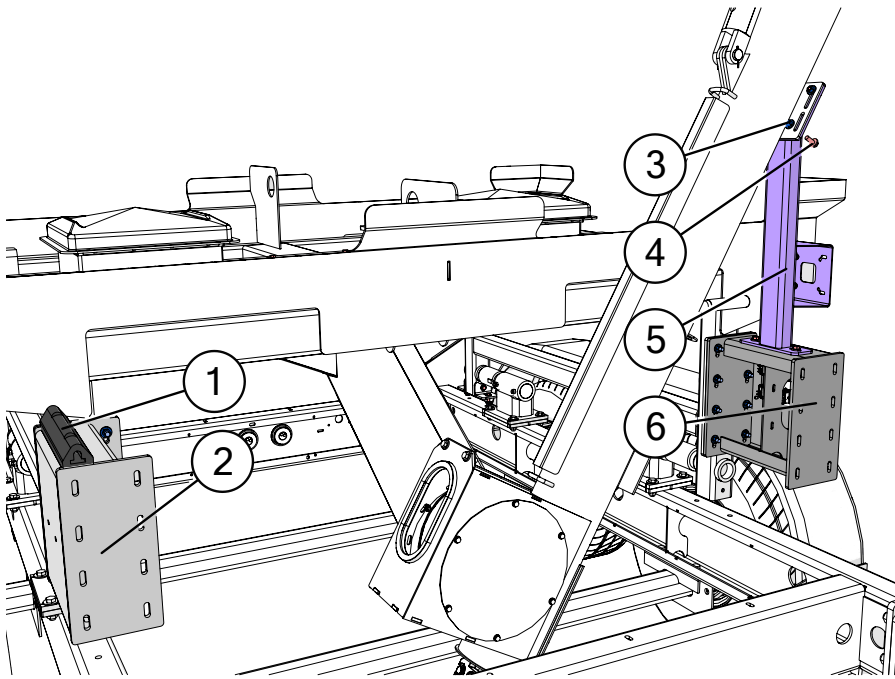

	Description	Part No.
1	12" x 2" Dock Bumper	JM0001890
2	Auger Rest and Box Support (Passenger Side)	JM0076979
3	3/8"-16 Gr5 Z SF Hex Nut	JM0002152
4	3/8"-16 x 1" Gr5 Z SF Hex Bolt	JM0002092
5	Vertical Auger Brace (251 & 451)	JM0076861
6	Control Mount and Box Support (Driver Side)	JM0076841
7	3/8"-16 x 1" Gr5 Z Hex Bolt	JM0001592
8	3/8" USS Flat Washer	JM0003061
9	3/8"-16 Gr2 Z Centerlock Hex Nut	JM0001512
10	3/8"-16 x 1-1/2" Gr5 Z SF Hex Bolt	JM0001633

Cleanout Door

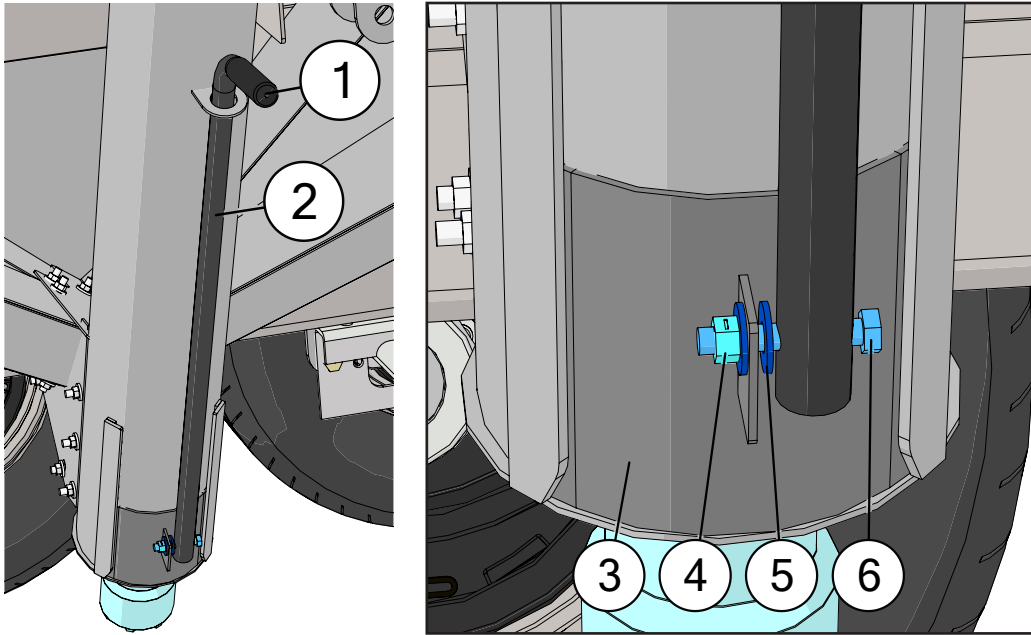

	Description	Part No.
1	1" ID x 6" Black Slide on Round Grip (6BSR)	JM0024290
2	Clean Out Door Handle	JM0022273
3	Clean Out Door Weldment (SpeedTender Pro)	JM0030692
4	3/8"-16 Gr2 Z Centerlock Hex Nut	JM0001512
5	3/8" ID, 1" OD Z Flat Washer	JM0003061
6	3/8"-16 x 2" Gr5 Z Hex Bolt	JM0001510

Spare Tire

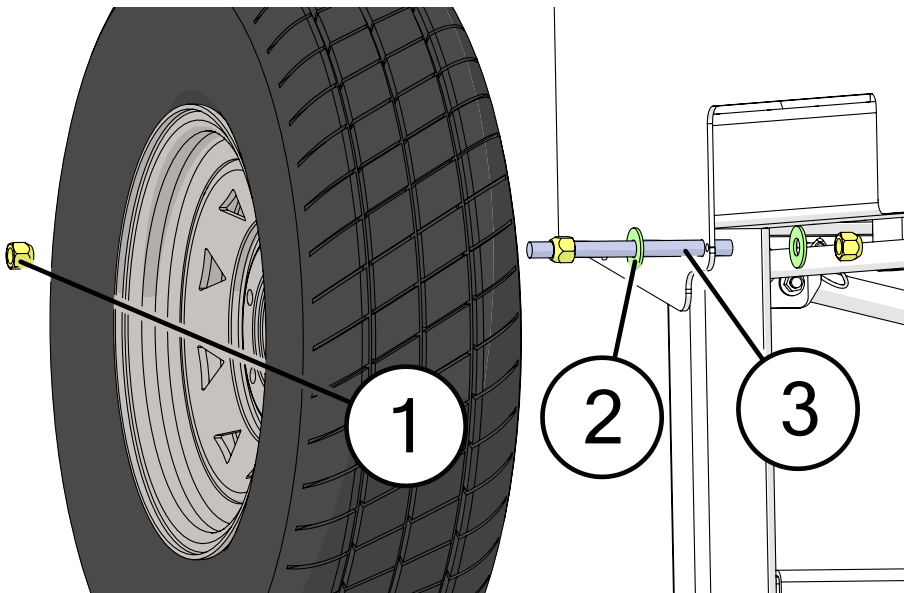

	Description	Part No.
1	9/16" USS Flat Washer	JM0050968
2	9/16"-18 Conical Lugnut (4WS) (ST)	JM0008525
3	9/16"-18 x 7-1/2" Full Thread Stud	JM0010068

Talc

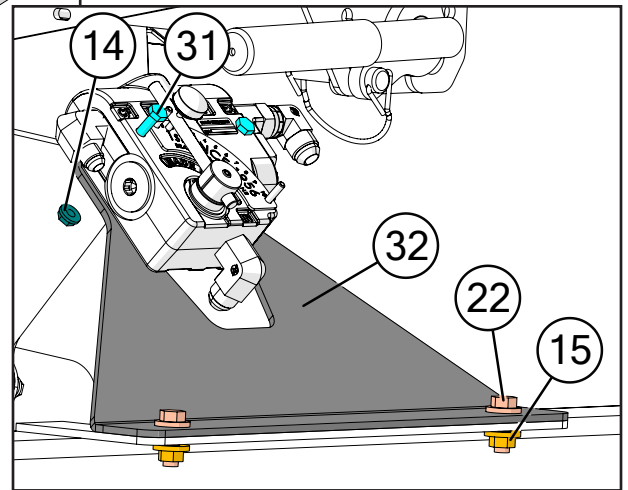
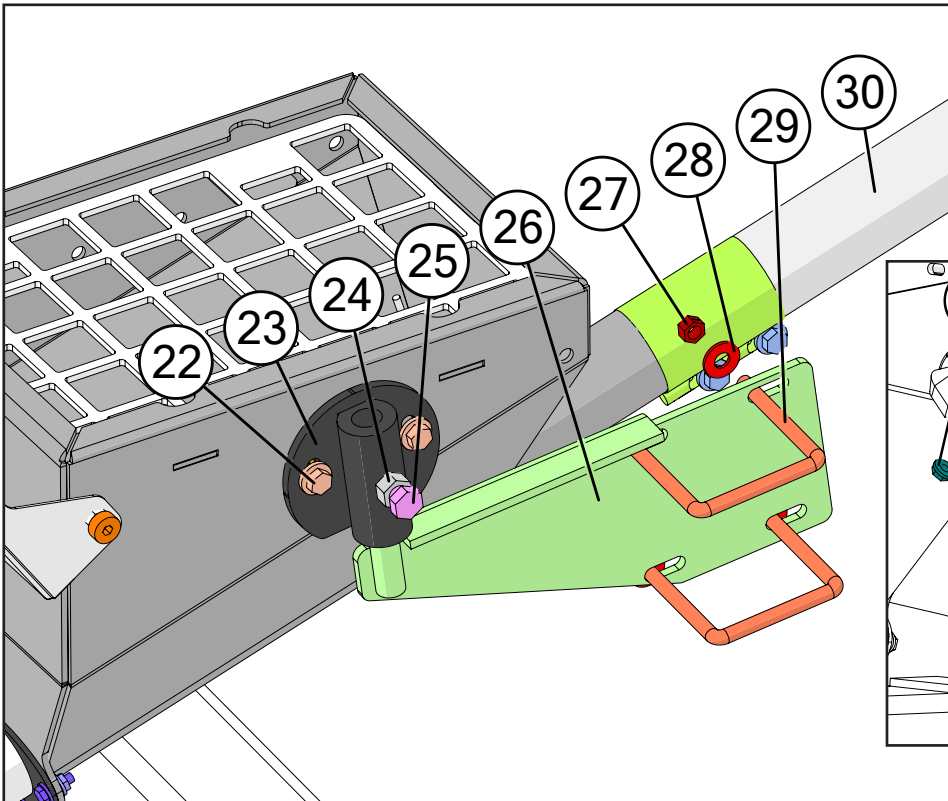
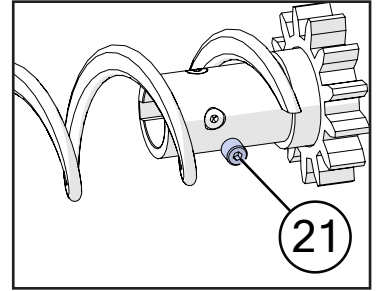
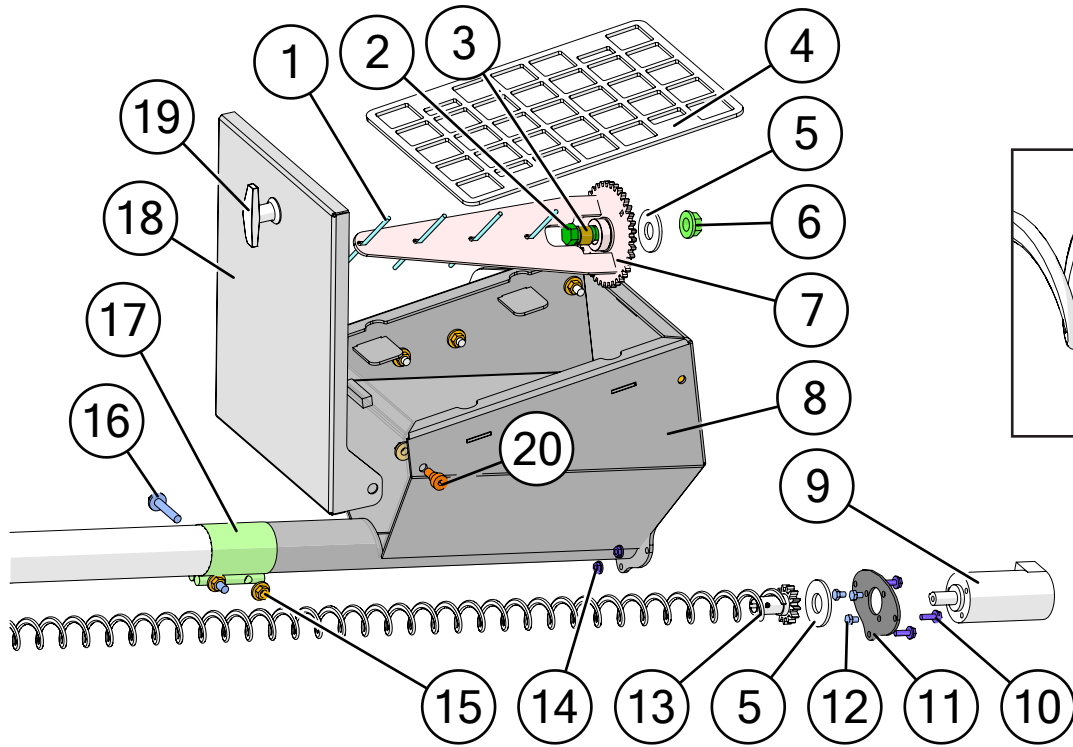

Talc

	Description	Part No.
1	3/16" Nylon Rod for Talc Agitator	JM0062689
2	3/4" Shoulder Dia x 1" Shoulder Length x 5/8"-11 Hex Head Shoulder Bolt and Nut (SB-34)	JM0003181
3	3/4" ID x 7/8" OD x 5/8" LG Bronze Bushing (BB-34)	JM0009455
4	Large Talc Box Screen (Electric & Hydraulic Motor)	JM0037456
5	3/4" USS Z Flat Washer	JM0010006
6	5/8"-18 Gr5 Z SF Hex Nut	JM0043101
7	Large Agitator 17 Deg. (Electric & Hydraulic Motor)	JM0037241
8	17 Deg. Talc Box Weldment (Electric & Hydraulic Motor)	JM0037538
9	White Drive Hydraulic Motor - 125032JL5C3AAAAA	JM0042491
10	1/4"-20 x 3/4" Gr5 Z SF Hex Bolt	JM0001642
11	Flange Plate for Talc Hydraulic Motor	JM0059070
12	1/4"-28 x 3/8" Gr5 Z Hex Bolt	JM0043100
13	535, c450, 51 Series Flex Auger Flighting Weldment 88-5/8" 2020 and Newer	JM0083248
14	1/4"-20 Gr5 Z SF Hex Nut	JM0001630
15	3/8"-16 Gr5 Z SF Hex Nut	JM0002152
16	3/8"-16 x 2" Gr5 Z SF Hex Bolt	JM0016070
17	2" Exhaust Clamp with Fasteners (Electric & Hydraulic Motor)	JM0037668
18	17 Deg. Talc Box Door (Electric & Hydraulic Motor)	JM0037237
19	Chrome T-Handle Non-Locking	JM0001911
20	1/2" Shoulder Dia x 3/8" Shoulder Length x 3/8"-16 Socket Shoulder Bolt	JM0009998
21	10-32 x 1/4" Cup-Point Set Screw	JM0076511
22	3/8"-16 x 1" Gr5 Z SF Hex Bolt	JM0002092
23	Talc Rotation Bracket Weldment (Electric & Hydraulic Motor)	JM0038395
24	1/2"-13 Gr2 Z Hex Nut	JM0002124
25	1/2"-13 x 1" Gr5 Z Hex Bolt	JM0010225
26	51 Series Talc Mounting Bracket	JM0077683
27	3/8"-16 Gr2 Z Centerlock Hex Nut	JM0001512
28	3/8" USS Flat Washer	JM0003061
29	3/8"-16 x 3-1/8" Inside Width x 4" Length; Square U-Bolt	JM0079516
30	Flex Auger Heat Bent PVC Pipe, 535, c450, 51 Series	JM0043049
31	1/4"-20 x 2-1/2" Gr5 Z Hex Bolt	JM0001506
32	Hydraulic Talc Flow Control Mounting Bracket	JM0043097

