

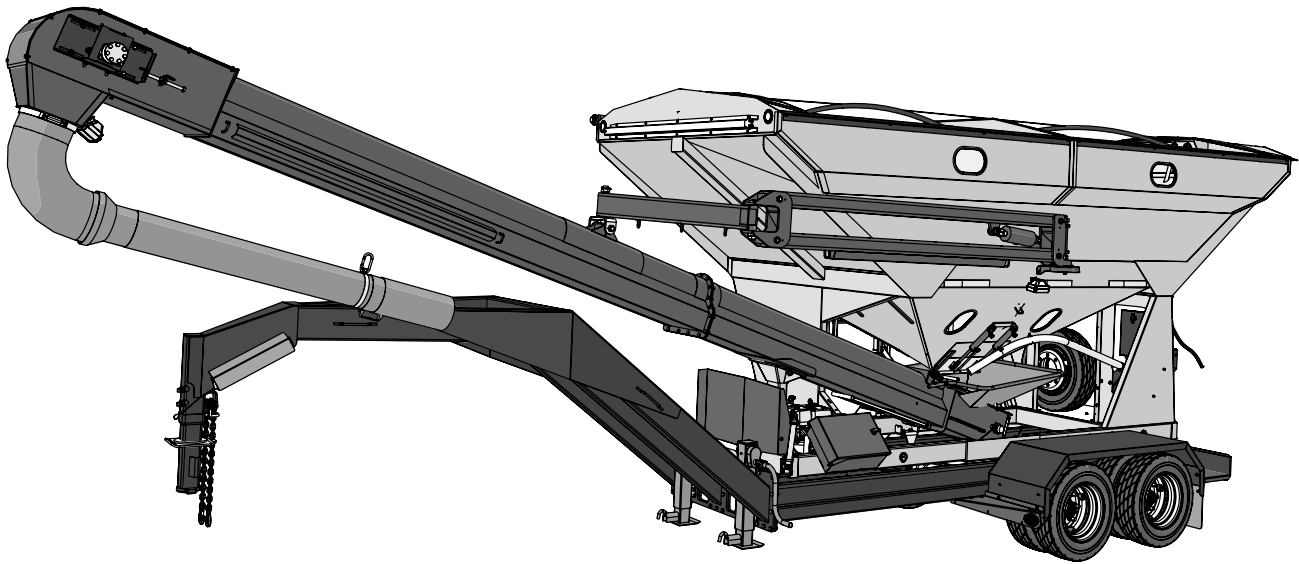

# Manual

## SPEED TENDER OPERATOR'S MANUAL

MODEL **LC535**



Rev. 5.9.2024

J&M Manufacturing Co, Inc

284 Railroad Street - P.O. Box 547 | Fort Recovery, OH 45846 | Ph: (419) 375-2376 | Fax: (419) 375-2708

[www.jm-inc.com](http://www.jm-inc.com)



# Table Of Contents

To the Dealer .....	4
General Information .....	5
Safety Rules .....	6
Specifications .....	7
Decals .....	8
Bolt Torque Specifications .....	10
Operations .....	11
General Service .....	17
Hydraulic Power Service .....	18
Tire Service .....	19
Wheel Bearing Service .....	20
Conveyor Service .....	21
Brakes Service .....	23
Troubleshooting .....	26
Valve Wiring .....	28
Throttle Control for Kar-Tech .....	29
Wired Controls and Scale Monitor .....	30
Kar-Tech Wireless Controls and Scale Monitor .....	31
Intercomp Wireless Controls and Scale Monitor .....	32
Battery Disconnect .....	32
Lights and Wiring .....	33
Scale Display Box .....	36
Scale Bar Mount .....	37
Non-Scale Bar Mount .....	37
Chassis .....	38
16k Axle Dexter .....	39
Gooseneck .....	40
Hydraulic Jack .....	42
Spare Tire Mount .....	45
Swing Arm .....	46
Conveyor .....	48
Conveyor Discharge End .....	49
Conveyor Idler End .....	50
Shell .....	52
Hydraulic Door .....	54
Ladder .....	55
Silver Hydraulic Valve JM0029973 .....	56
Gold Hydraulic Valve JM0080426 .....	58
Blue Hydraulic Valve JM0080825 .....	60
Talc Applicator .....	62
Talc Hydraulics Schematic for Aluminum Valve .....	64
Electronic Talc Hydraulics Schematic for Silver and Gold Valves .....	65
Electronic Talc Hydraulics Schematic for Blue Valve .....	66
Spring Return .....	67
Roll Tarp .....	68

# To the Dealer

## TO THE DEALER

Read manual instructions and safety rules. Make sure all items on the Dealer's Pre-Delivery and Delivery Check Lists are completed before releasing equipment to the owner.

The dealer must complete the Warranty Registration found on the Dealer Portal website located at dealer.jm-inc.com and return it to J&M Mfg. Co., Inc. at the address indicated on the form. Warranty claims will be denied if the Warranty Registration has not been submitted.

### EXPRESS WARRANTY:

J&M Mfg. Co. Inc. warrants against defects in construction or materials for a period of ONE year. We reserve the right to inspect and decide whether material or construction was faulty or whether abuse or accident voids our guarantee.

Warranty service must be performed by a dealer or service center authorized by J&M Mfg. Co., Inc. to sell and/or service the type of product involved, which will use only new or remanufactured parts or components furnished by J&M Mfg. Co., Inc. Warranty service will be performed without charge to the purchaser for parts or labor based on the Warranty Labor Times schedule. Under no circumstance will allowable labor times extend beyond the maximum hours indicated in the Warranty Labor Times schedule for each warranty procedure. The purchaser will be responsible, however, for any service call and/or transportation of the product to and from the dealer or service center's place of business, for any premium charged for overtime labor requested by the purchaser, and for any service and/or maintenance not directly related to any defect covered under the warranty. Costs associated with equipment rental, product down time, or product disposal are not warrantable and will not be accepted under any circumstance.

Each warranty term begins on the date of product delivery to the purchaser. Under no circumstance will warranty be approved unless (i) the product warranty registration card has been properly completed and submitted to the equipment manufacturer, and (ii) a warranty authorization number has been issued by the equipment manufacturer. This Warranty is effective only if the warranty registration card is returned within 30 days of purchase.

This warranty does not cover a component which fails, malfunctions or is damaged as a result of (i) improper modification or repair, (ii) accident, abuse or improper use, (iii) improper or insufficient maintenance, or (iv) normal wear or tear. This warranty does not cover products that are previously owned and extends solely to the original purchaser of the product. Should the original purchaser sell or otherwise transfer this product to a third party, this warranty does not transfer to the third party purchaser in any way. J&M Mfg. Co., Inc. makes no Warranty, express or implied, with respect to tires or other parts or accessories not manufactured by J&M Mfg. Co., Inc. Warranties for these items, if any, are provided separately by their respective manufacturers.

THIS WARRANTY IS EXPRESSLY IN LIEU OF ALL OTHER WARRANTIES OR CONDITIONS, EXPRESS, IMPLIED OR STATUTORY, INCLUDING ANY IMPLIED WARRANTY OF MERCHANTABILITY OR FITNESS FOR PARTICULAR PURPOSE.

In no event shall J&M Mfg. Co., Inc. be liable for special, direct, incidental or consequential damages of any kind. The exclusive remedy under this Warranty shall be repair or replacement of the defective component at J&M Mfg. Co., Inc.'s option. This is the entire agreement between J&M Mfg. Co., Inc. and the Owner about warranty and no J&M Mfg. Co., Inc. employee or dealer is authorized to make any additional warranty on behalf of J&M Mfg. Co., Inc.

The manufacturer reserves the right to make product design and material changes at any time without notice. They shall not incur any obligation or liability to incorporate such changes and improvements in products previously sold to any customer, nor shall they be obligated or liable for the replacement of previously sold products with products or parts incorporating such changes.

### SERVICE:

The equipment you have purchased has been carefully manufactured to provide dependable and satisfactory use. Like all mechanical products, it will require cleaning and maintenance. Lubricate the unit as specified. Observe all safety information in this manual and safety signs on the equipment.

For service, your authorized J&M dealer has trained mechanics, genuine J&M service parts, and the necessary tools and equipment to handle all your needs.

Use only genuine J&M service parts. Substitute parts may void warranty and may not meet standards required for safety and satisfactory operation. Record the model number and serial number of your equipment in the spaces provided:

**Model No:** LC 535 SpeedTender **Serial No:** \_\_\_\_\_ **Date of Purchase:** \_\_\_\_\_

**Purchased From:** \_\_\_\_\_

Provide this information to your dealer to obtain correct repair parts.



# General Information

## TO THE OWNER:

The purpose of this manual is to assist you in operating and maintaining your seed tender in a safe manner. Read it carefully. It furnishes information and instructions that will help you achieve years of dependable performance and help maintain safe operating conditions. If this machine is used by an employee or is loaned or rented, make certain that the operator(s), prior to operating:

1. Is instructed in safe and proper use.
2. Reviews and understands the manual(s) pertaining to this machine.

Throughout this manual, the term **IMPORTANT** is used to indicate that failure to observe can cause damage to equipment. The terms **CAUTION**, **WARNING** and **DANGER** are used in conjunction with the Safety-Alert Symbol, (a triangle with an exclamation mark), to indicate the degree of hazard for items of personal safety. When you see this symbol, carefully read the message that follows and be alert to the possibility of personal injury or death.



This Safety-Alert symbol indicates a hazard and means **ATTENTION! BECOME ALERT! YOUR SAFETY IS INVOLVED!**



**DANGER**

Indicates an imminently hazardous situation that, if not avoided, will result in death or serious injury.



**WARNING**

Indicates a potentially hazardous situation that, if not avoided, could result in death or serious injury, and includes hazards that are exposed when guards are removed.



**CAUTION**

Indicates a potentially hazardous situation that, if not avoided, may result in minor or moderate injury.

**IMPORTANT**

Indicates that failure to observe can cause damage to equipment.

**NOTE**

Indicates helpful information.

## SAFETY RULES:



Safety is a primary concern in the design and manufacture of our products. Unfortunately, our efforts to provide safe equipment can be erased by an operator's single careless act. In addition, hazard control and accident prevention are dependent upon the awareness, concern, judgment, and proper training of personnel involved in the operation, transport, maintenance and storage of equipment.

Make certain that the operator(s), prior to operating is instructed in safe and proper use and reviews and understands the manual(s) pertaining to this machine. Also make certain that the operator(s) reviews and understands the operator's manual of the tow vehicle prior to hooking up or operating the SpeedTender.

Read this manual before you operate this machine. If you do not understand any part of this manual, or need more information, contact the manufacturer or your authorized dealer.

**Safety Rules Continued on Next Page**

# Safety Rules

1. Understand that your safety and the safety of other persons are measured by how you service and operate this machine. Know the positions and functions of all controls before you try to operate them. Make sure to check all controls in a safe area before starting your work.
2. The safety information given in this manual does not replace safety codes, federal, state, or local laws. Make certain your machine has the proper equipment as designated by local laws and regulations.
3. A frequent cause of personal injury or death is from persons falling off equipment and being run over. Do not permit persons to ride on this machine.
4. Secure SpeedTender safety chain to towing vehicle before transporting. Do not transport without safety chains being attached to tow vehicle.
5. Make sure that the conveyor is resting on the conveyor support with spring latch in place before transport.
6. Use good judgment when transporting SpeedTender on a highway. Always maintain complete control. Regulate speed to road conditions. Do not transport unit with rear compartment full and front compartment empty. The unit may not be properly balanced, offsetting the tongue weight of the SpeedTender.
7. When transporting on public roads, the conveyor must be in the forward position to meet with lighting and visibility marking requirements.
8. Do not travel faster than 10 mph during off highway travel. Drive slowly over rough ground, hill sides, and around curves to avoid tipping. Use extreme care when operating close to ditches, fences, or on hillsides.
9. Use care when moving or operating SpeedTender near electric lines as serious injury or death can result from contact.
10. Never adjust, service, clean, or lubricate SpeedTender until all power is shut off and the battery is disconnected. Keep all safety shields in place.
11. Carbon monoxide can cause severe nausea, fainting, or death. Do not operate engine in closed or confined work area.
12. Explosive fuel can cause fires and severe burns. Stop engine before filling fuel tank.
13. Hot parts can cause severe burns. Do not touch engine while operating or just after stopping.
14. Hydraulic oil leaking under pressure can penetrate skin and cause infection or other injury.
15. To prevent personal injury when working with hydraulic power unit:
  - a. Relieve all pressure before disconnecting fluid lines.
  - b. Before applying pressure, make sure all connections are tight and components are in good condition.
  - c. Never use your hand to check for suspected leaks under pressure. Use a piece of cardboard or wood for this purpose.
16. Make sure that everyone is clear of equipment before applying power or moving the SpeedTender.
17. Before filling the SpeedTender, make certain that no one is inside the grain tanks. Never allow children, or anyone, in, near, or on the SpeedTender during transport or during loading and unloading of grain. Be aware that moving grain is dangerous and can cause entrapment, resulting in severe injury or death by suffocation.
18. Before unhooking the SpeedTender from the transport vehicle, be sure to properly block the wheels to prevent the SpeedTender from moving.
19. When using the conveyor swing option be sure to stand clear of the swinging conveyor at all times.

# Specifications



Capacity (Total)	Weight (Empty)	Tongue Weight (Loaded)	Conveyor	Unloading Rate	Conveyor	Axles	Engine
535 Seed Units	10,400 lbs	4,900 lbs	24'6" Long, 10" Tube Conveyor	45 Bushels/Minute	50' (Front to Rear Swing)	Two (2), 16,000 lb. Dual Wheel, Spring Ride with Electric Brakes	13 HP Honda Motor with Electric Start

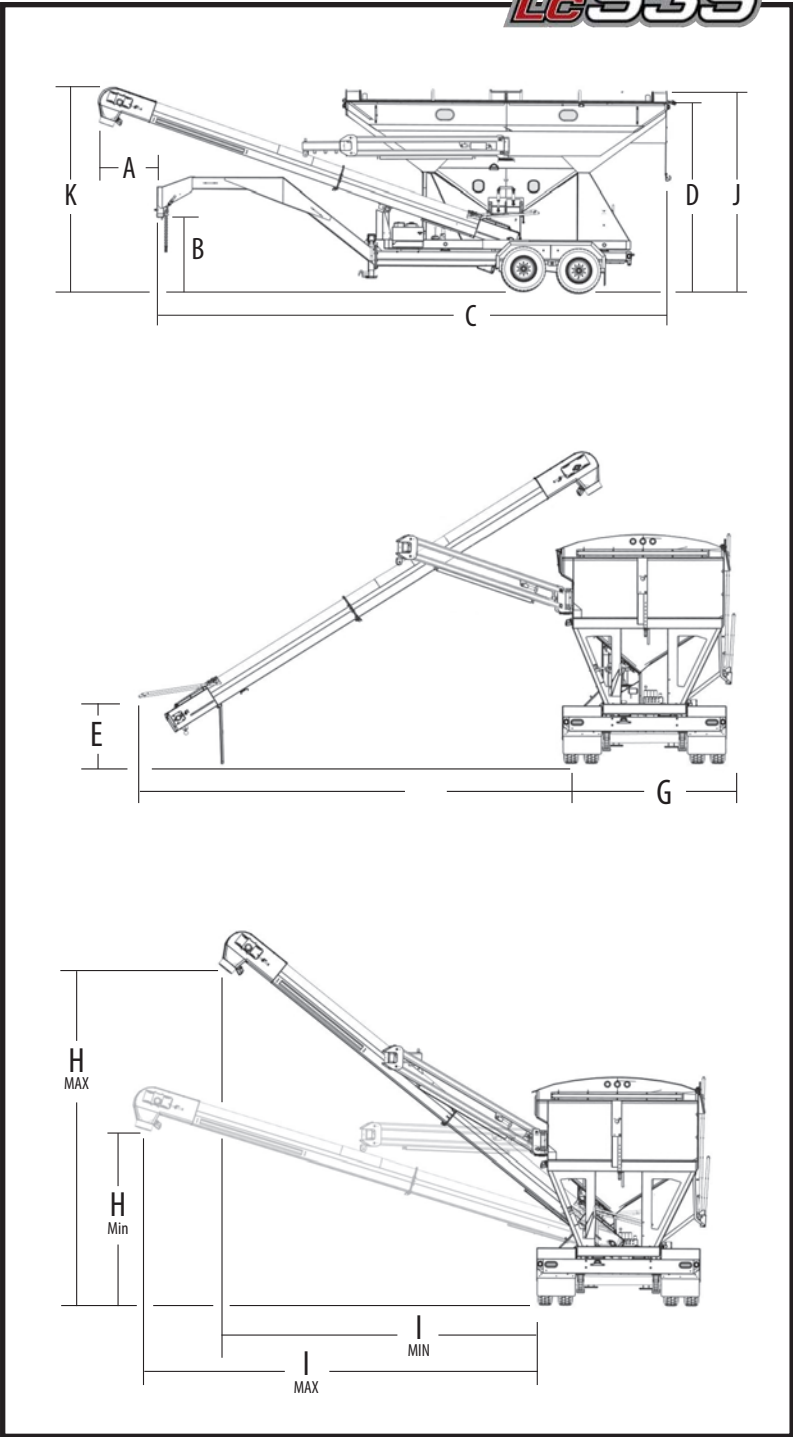

Gooseneck	
A	3'-6"
B	2'-9" (Min.)
B	3'-4" (Max.)
C	29'-2"
D	10'-8"
E	4'-0"
F	20'-2"
G	8'-6"
H	8'-7" (Min.)
H	17'-0" (Max.)
I	16'-2" (Min.)
I	20'-4" (Max.)
J	11'-5"
K	11'-0"



# Decals

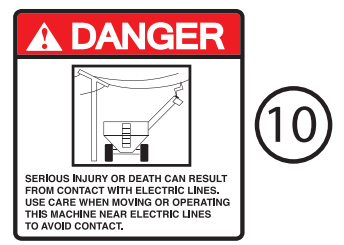
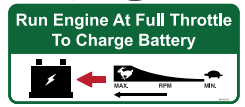
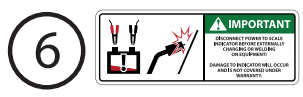
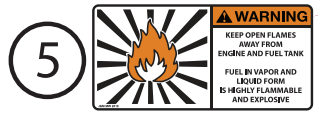
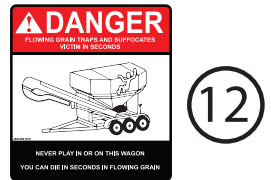
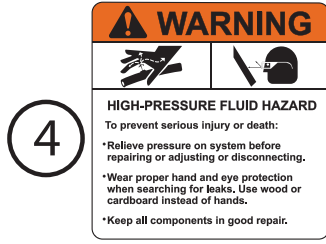

Description	Part No.
1 SpeedTender Advanced Seed Delivery	JM0040057
2 LC Series Decal	JM0049466
3 J&M Oval Decal (Large) 9-1/2" x 15"	JM0015151
4 Warning, High Pressure Fluid Hazard Decal 4" x 4"	JM0010163
5 Warning, Keep Open Flames Away Decal	JM0014983
6 Important, Disconnect Power To Scale Decal	JM0040056
7 Warning, Always Use Safety Chains Decal	JM0014995
8 Warning, Trailer Can Roll Decal	JM0014997
9 Run Engine At Full Throttle To Charge Battery Decal	JM0032425
10 Danger, Electric Lines Decal	JM0015099
11 Warning, Do Not Adjust (4 Bullets) Decal	JM0018040
12 Danger, Flowing Grain Traps ST Decal	JM0014969
13 Warning, Moving Parts Can Crush and Cut Decal	JM0014993
14 J&M Oval Decal (Medium) 5-1/2" x 8-1/2"	JM0010179





# Decals

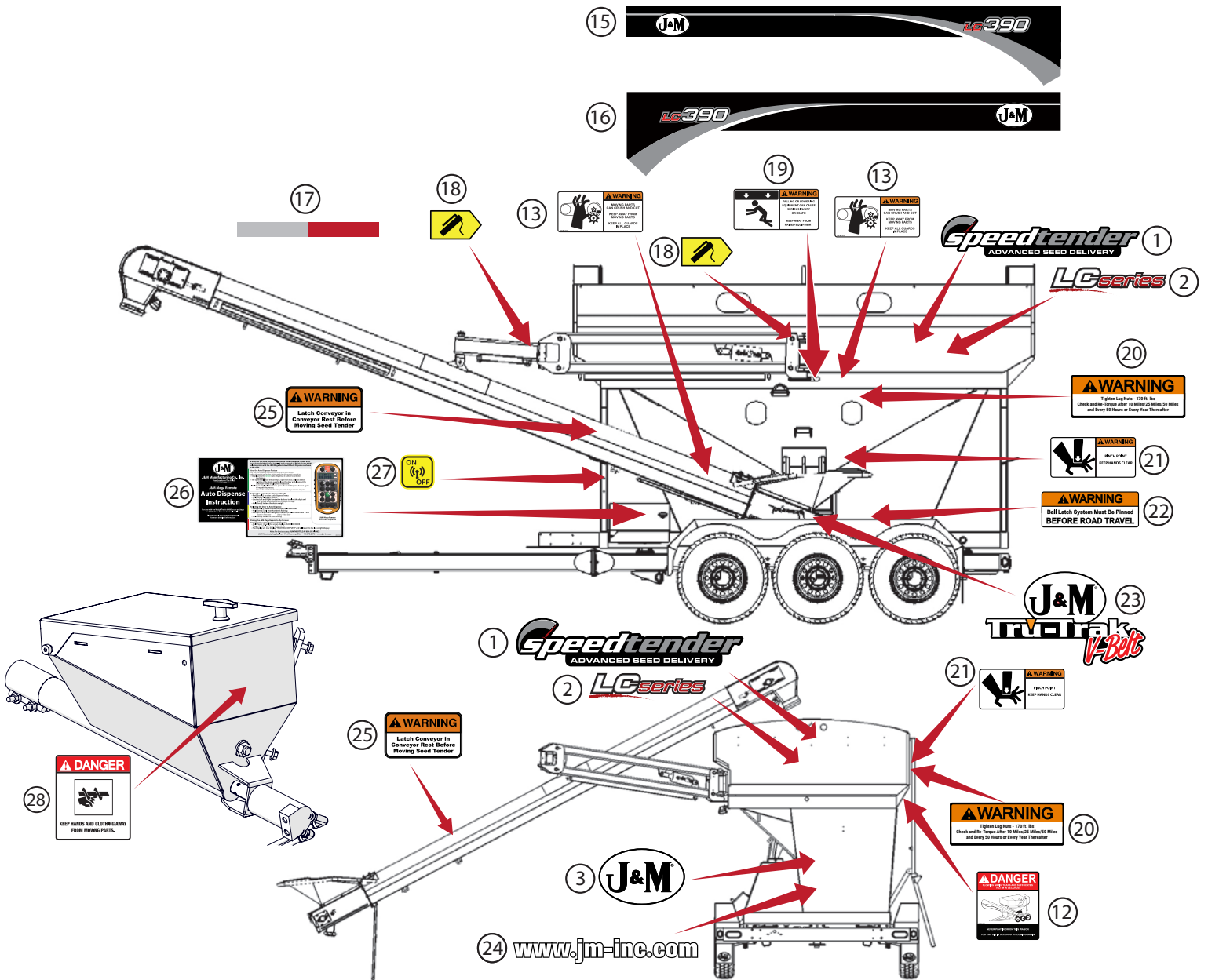

Description	Part No.
15 #N/A!	
16 #N/A!	
17 2" x 18" Red and White Reflective Strip	JM0015079
18 Grease Point Decal	JM0040055
19 Warning, Falling Or Lowering Decal	JM0014992
20 Warning, Tire Wheel or Lug Nut Failure Decal	JM0014996
21 Warning, Pinch Point Decal	JM0014994
22 Warning, Ball Latch System Decal	JM0040058
23 J&M Oval, Tru-Trak V-Belt Combo Decal	JM0037730
24 www.jm-inc.com Decal	JM0019239
25 Warning, Latch Conveyor Decal	JM0040054
26 Auto Dispense Instructions Decal	JM0037816
27 On/Off Decal (ST)	JM0014974
28 Danger, Keep Hands and Clothing Away Decal	JM0018035

# Bolt Torque Specifications

Always tighten hardware to these values unless a different torque or tightening procedure is listed for specific application. Fasteners must always be replaced with the same grade as specified in the manual parts list. Always use the proper tool for tightening hardware. Make sure fastener threads are clean and you start thread engagement properly. **Use these values when tightening all bolts and nuts with the exception of wheel nuts.**

## SAE Fasteners

Coarse Thread Series				
Diameter and Pitch (Inches)	Grade 5		Grade 8	
	Dry	Oiled	Dry	Oiled
1/4"-20	8 ft-lbs	6 ft-lbs	12 ft-lbs	9 ft-lbs
5/16"-18	17	13	25	18
3/8"-16	31	23	44	33
7/16"-14	49	37	70	52
1/2"-13	75	57	106	80
9/16"-12	109	82	154	115
5/8"-11	150	113	212	159
3/4"-10	267	200	376	282
7/8"-9	429	322	606	455
1"-8	644	483	909	681
Fine Thread Series				
Diameter and Pitch (Inches)	Dry	Oiled	Dry	Oiled
1/4"-28	10 ft-lbs	7 ft-lbs	14 ft-lbs	10 ft-lbs
5/16"-24	19	15	27	20
3/8"-24	35	26	49	37
7/16"-20	55	41	78	58
1/2"-20	85	64	120	90
9/16"-18	121	91	171	128
5/8"-18	170	127	240	180
3/4"-16	297	223	420	315
7/8"-14	474	355	669	502

## Stud and Wheel Nut Torque Specifications

Always tighten hardware to these values unless a different torque or tightening procedure is listed for specific application. Fasteners must always be replaced with the same grade as specified in the manual parts list. Always use the proper tool for tightening hardware. Make sure fastener threads are clean and you start thread engagement properly. **Use these values when tightening all studs and wheel nuts.**

Stud	Tightening Torque
1/2"-20	120 ft-lbs
9/16"-18	170 ft-lbs
5/8"-18	300 ft-lbs
3/4"-16	400 ft-lbs
20mm	475 ft-lbs
22mm	640 ft-lbs

**TIGHTENING WHEEL NUTS:** Torque 9/16"-18 lug nuts on wheels to 170 ft-lbs after the first 10, 25, and 50 miles of driving, then recheck torque every 50 hours or every year, whichever comes first. Failure to do so may damage wheel nut seats. Once seats are damaged it will become impossible to keep nuts tight.

# Operations

## **Preparing the Towing Vehicle**

1. Before towing the SpeedTender, refer to towing vehicle's operator's manual for information concerning hitch capacities, hitch adjustments, and tire inflation.
2. Towing vehicle must be equipped with proper electric braking components.  
**NOTE: The SpeedTender is equipped with LED lights. The towing vehicle may require a flasher upgrade for lights to operate properly.**
3. Do not exceed towing vehicle's GVWR (Gross Vehicle Weight Rating) or GCWR (Gross Combination Weight Rating), or the maximum hitch load.

## **Preparing SpeedTender**

1. Hydraulics: Check routing of all hydraulic hoses. Hoses should not be kinked, twisted or rubbing against sharp edges. Check all hoses and fittings for hydraulic leaks. Tighten, repair, or replace as required.
2. Lubrication: Lubricate SpeedTender as outlined in "General Service" on page 17. Refer to engine operator's manual for proper fluid levels in engine.
3. Tires/Wheels: Check tire pressures and maintain at recommended operating pressure. It is important to check wheel nut/bolts for proper torque as recommended. Refer to "Tire Service" on page 19 for proper tire pressure and wheel torque specifications.

## **Connecting SpeedTender to the Towing Vehicle**

**⚠ WARNING: Do not stand between the SpeedTender and tow vehicle when hooking up.**

**NOTE: The gooseneck frame can feature either a 2-5/16" ball coupler or a 5th wheel hook up.**

1. Back tow vehicle up to SpeedTender.
2. Align the vehicle's ball or 5th wheel hook up with the coupler or ring on the SpeedTender.
3. Lift tongue latch lever.
4. Lower jack to set SpeedTender coupler down on ball.
5. Latch coupler and insert pin. Check to make sure that coupler is securely latched.
6. Raise the "drop leg" of the jack.
7. Attach 7-way plug to tow vehicle. Check the length of the SpeedTender 7-way plug to make sure it is long enough to turn, but not too long to touch the ground.

**NOTE: Check to make sure that lights are in proper operating condition and repair or replace if necessary.**

8. Connect the brake breakaway cable to towing vehicle.
9. Attach safety chains to tow vehicle by crossing chains. Allow enough slack in chains to allow for turning.
10. Test the brakes and all the lights on the SpeedTender.

**⚠ WARNING: Check safety chains for broken, stretched or damaged link or end fittings. Replace chains if found to be damaged. Do not weld safety chains.**

## **Transporting**

1. Lift jack to the highest position.
2. Ensure the conveyor is in the conveyor rest and strapped down.
3. Ensure the collapsible hopper is in down position with the vinyl hopper cover applied.
4. When transporting the SpeedTender on public roads, it is recommended to have the conveyor in the forward-facing position. The rearward-facing position may not comply with state law for lighting and marking requirements.

**⚠ WARNING: Travel at a safe speed to maintain complete control of towing vehicle and SpeedTender at all times.**



# Operations

## **Hydraulic Power Unit Operation**

Ensure all fittings and hardware are in proper operating condition. Replace if worn or broken. Check engine fluid levels and sight gauge on reservoir for proper operating levels.

1. Slide the fuel shut-off lever to the "ON" position.
2. Slide choke to the "ON" position.
3. Turn the key to the start position. Once engine starts, release key.
4. After starting, allow the engine to warm up. Slide choke to the "OFF" position and increase throttle speed.
5. The engine must throttle at, or above 80% throttle for 3 seconds to begin charge. After the 3 seconds at 80% throttle the battery will continue to charge until the engine is turned off.
6. To turn the engine off, slide the fuel shut-off lever to the "OFF" position.
7. Turn key off.

**NOTE: In extremely cold weather, it is best to allow engine and hydraulics to warm up before increasing throttle speed.**

**NOTE: If a hydraulic leak appears, turn off immediately and take appropriate action.**

**NOTE: See engine operator's manual for more details on upkeep and service.**

- ⚠ WARNING: Purge hydraulic system of air before operating SpeedTender to prevent serious injury or death.**
- ⚠ WARNING: Wear proper hand and eye protection when searching for leaks. Use wood or cardboard instead of hands.**
- ⚠ WARNING: Explosive fuel can cause fires and severe burns. Stop engine before filling fuel tank.**
- ⚠ WARNING: Carbon monoxide can cause severe nausea, fainting or death. Do not operate engine in an enclosed or confined area.**
- ⚠ WARNING: Hot parts can cause severe burns. Do not touch engine while operating or just after stopping.**
- ⚠ WARNING: Acid from battery can cause fires and severe acid burns. Make sure to charge battery in well-ventilated area.**
- ⚠ WARNING: Make sure to relieve hydraulic pressure before working on hydraulic system.**

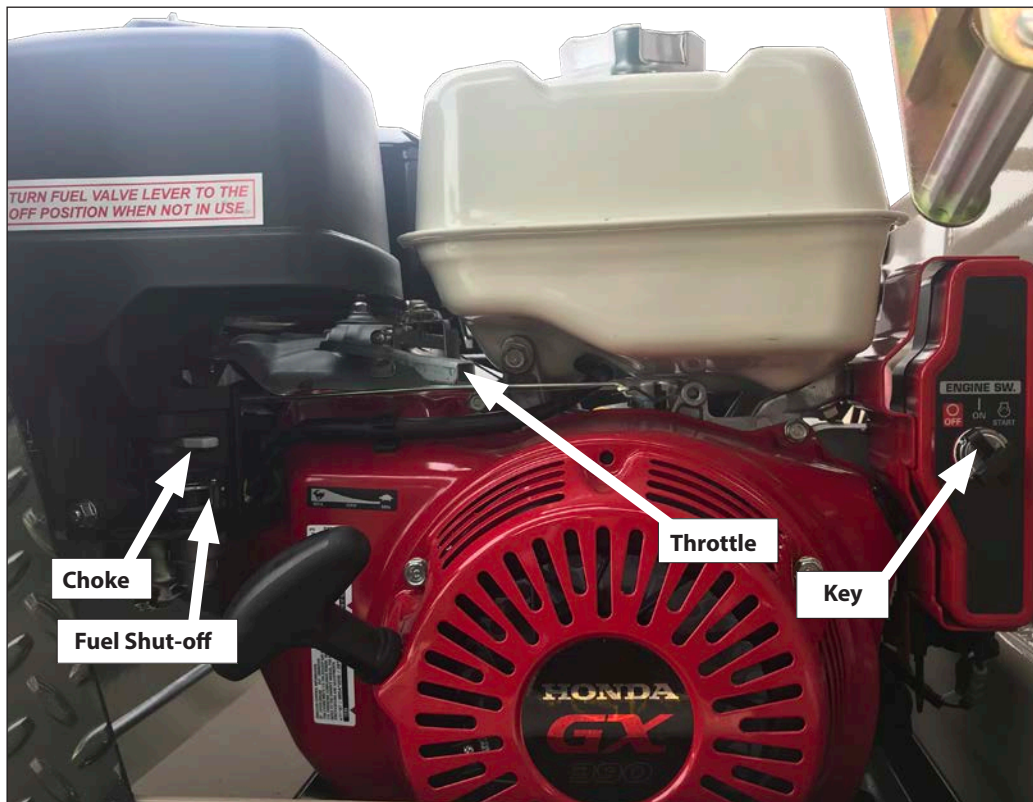

# Operations

## Field Operation

**⚠ WARNING: The SpeedTender must be hooked to the towing vehicle during loading and unloading.**

1. Position the SpeedTender next to the planter/drill so the conveyor will reach the planter box.
2. Release the ratchet strap from the conveyor.
3. Start the hydraulic power unit and increase throttle speed. Allow hydraulic fluid to warm up.
4. Raise the conveyor off the conveyor rest using the handheld control.

**⚠ WARNING: When operating the hydraulic swing option, do not stand in the operating range of the conveyor.**

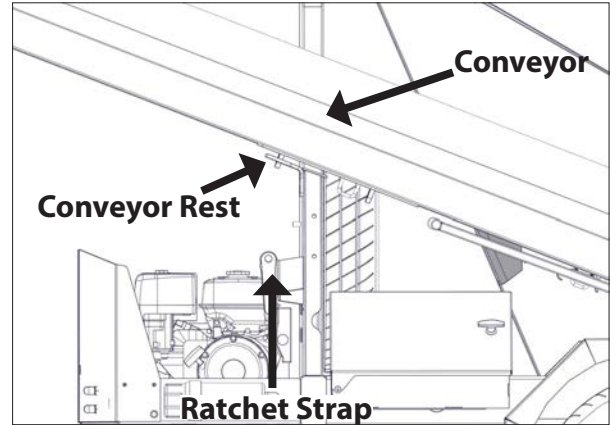
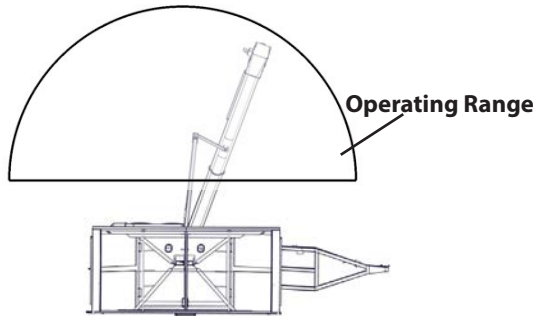

5. Check to make sure the hopper is in the up position.
6. Open door on SpeedTender using the supplied remote.

**⚠ WARNING: Empty the rear compartment first to prevent the chance of flipping the SpeedTender.**

7. Use the handheld controller or wireless remote to start the conveyor.
8. Fill the planter/drill to desired level then repeat.

**NOTE: Adjusting engine throttle will regulate conveyor speed.**

9. Close door on SpeedTender before the last planter seed box is full so you can completely empty collapsible hopper and conveyor.
10. Position conveyor above conveyor rest and lower to allow its full weight on the conveyor rest.
11. Lock down conveyor using the ratchet strap.
12. Collapse the hopper to the down position and apply the vinyl hopper cover.
13. Slide the fuel shut-off lever to the "OFF" position. This will allow the engine to shutoff by running out of gas.
14. Turn the key to the "OFF" position.

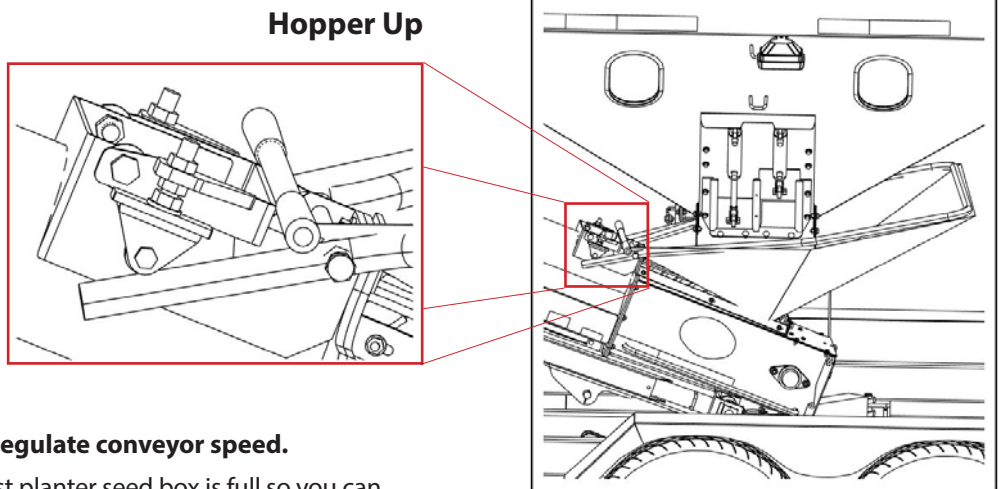

# Operations

## ***Filling SpeedTender From Another Wagon or Bulk Container***

**⚠ WARNING:** The SpeedTender must be hooked to the towing vehicle during loading and unloading.

1. Release ratchet strap from conveyor.
2. Start the hydraulic power unit and increase throttle speed. Allow hydraulic fluid to warm up.

**NOTE:** Make sure collapsible hopper is in the down position.

3. Raise the conveyor off the conveyor rest using the handheld control.

**⚠ CAUTION:** If you are parked on an incline, the conveyor may swing freely. It is advised that you do not use the SpeedTender on uneven ground.

Rotate the conveyor to 45°.

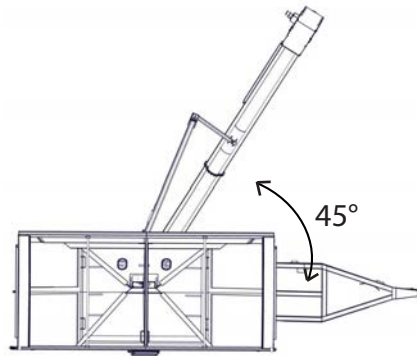

4. Lower the conveyor so you can remove the telescoping spout from the discharge end of the conveyor.
5. Remove pins and raise up both handles to release ball from latch system. Slide the ball away from the middle of the tender, then swing the collapsible hopper end out from under the SpeedTender shell.
6. Position the discharge end over the SpeedTender.
7. Lock the conveyor in place. The conveyor is equipped with a stand. (It is recommended for use whenever possible to maximize conveyor performance and for easier access to discharge point on bulk seed containers).
8. Lock collapsible hopper in the up position.
9. Position the wagon or bulk seed container over the collapsible hopper.
10. Use the handheld controller or wireless remote to start the conveyor.
11. Fill the SpeedTender to desired level.

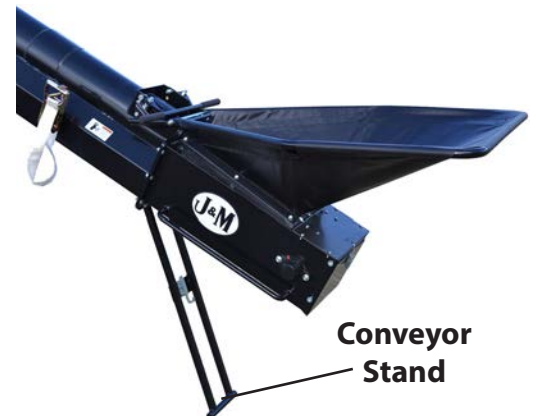

**⚠ WARNING:** Fill the front compartment first to help prevent the chance of flipping.

12. Run the conveyor until the collapsible hopper is empty.
13. When finished loading seed into the SpeedTender, move the wagon or bulk seed container away from conveyor.
14. Collapse the hopper to the down position and apply the vinyl hopper cover.
15. With the conveyor at a 45° angle, swing the conveyor hopper back under the tank and slide ball back into latch system. Replace both pins on latch handles.
16. Position conveyor above the conveyor rest and lower to allow its full weight on the rest.
17. Lock down conveyor using the ratchet strap.
18. Slide the fuel shut-off lever to the "OFF" position. This will allow the engine to shutoff by running out of gas.
19. Turn the key to the "OFF" position.

# Operations

## Cleaning out Collapsible Hopper and Conveyor

**⚠ WARNING: The SpeedTender must be hooked to the towing vehicle during loading and unloading.**

1. Release strap from conveyor.
2. Start the hydraulic power unit and increase throttle speed. Allow hydraulic fluid to warm up if it is cold outside.  
**NOTE: Ensure collapsible hopper is in the down position.**
3. Raise the conveyor out of conveyor rest using the handheld control.  
**⚠ CAUTION: If you are parked on an incline, the conveyor may swing freely. Use of the SpeedTender on uneven ground is not advised.**
4. Rotate the conveyor to 45°.
5. Lower the conveyor so you can remove the telescoping spout from the discharge end of the conveyor.
6. Swing the collapsible hopper end out from under the SpeedTender shell.
7. Place the collapsible hopper in the up position.
8. With the discharge end lower than the collapsible hopper end, place the discharge end into a 5 gallon bucket. Using the handheld controller, start the conveyor and run until completely empty.
9. Lower the collapsible hopper end back down to the ground. This will allow you to open the **conveyor clean out door**.  
**⚠ CAUTION: Ensure all power is shut off before opening conveyor clean out door.**
10. Place collapsible hopper in the down position
11. With the conveyor at a 45° angle, swing the conveyor hopper back under the tank and slide ball back into latch system. **Replace both pins on latch handles.**
12. Position conveyor above conveyor rest and lower to allow its full weight on the conveyor rest.
13. Tighten strap and ensure it is secured.
14. Ensure the collapsible hopper is in the down position and apply the vinyl hopper cover.
15. Slide the fuel shut-off lever to the "OFF" position. This will allow the engine to shutoff by running out of gas.
16. Turn the key to the "OFF" position.

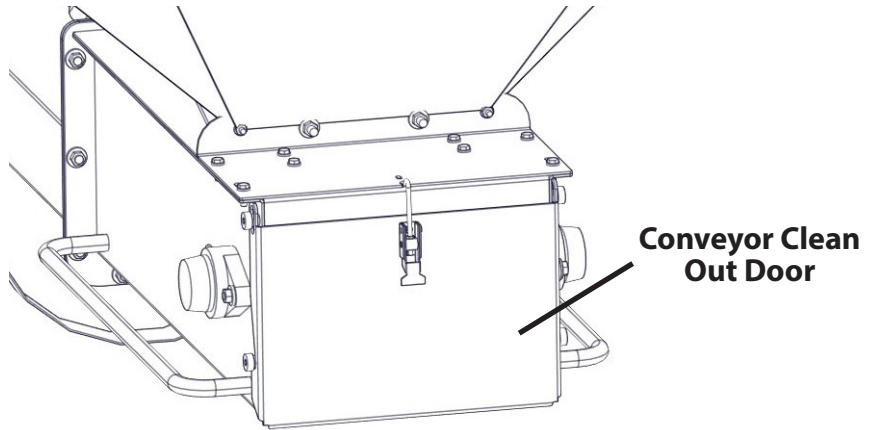

# Operations

## **Adjusting the Tarp Tension in Hanger Bracket**

1. Fully unroll the tarp as shown on the right.
2. Remove the two bolts that hold the tarp u-joint on the splined shaft.
3. Remove the u-joint from the splined shaft.
4. Rotate u-joint and handle three or four spline teeth.
5. **NOTE: Rotate clockwise to tighten the tarp or counterclockwise to loosen it.**
6. Slide the u-joint and handle back onto the spline shaft.
7. Replace and tighten the two bolts.

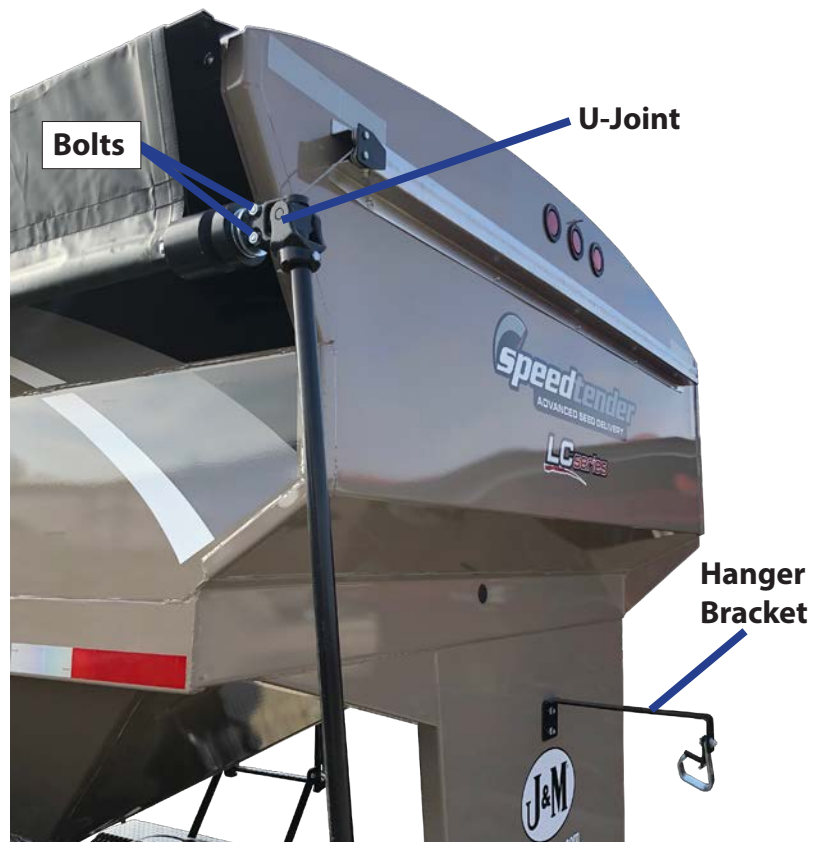

## **Basic Scale Operations**

1. Turn the scale "ON" by pressing the on/off button. The display shows "Hello" then the current weight value is displayed.
2. Press G/N to access the gross mode. (Live scale weight is displayed in the G/N weighing mode.)
3. In the gross mode, press the ZERO/CLEAR key to zero the indicator when the SpeedTender is empty.
4. After initial amount is placed on the scale, press the TARE Key. (Weight is tared off and goes into net mode, showing weight).
5. Load or unload material as needed (Shows + when loading and a - value when unloading).
6. When the display reaches the proper amount, stop loading or unloading.
7. Repeat steps 2 through 4 until complete.

**NOTE: For more information, refer to the scale manual.**

## **Basic Remote Operations**

1. For instructions on pairing your remote or setting up the auto dispense feature, see the instructions decal on the inside of the scale display box.
2. When using the optional Intercomp WC3-D remote, additional instructions can also be found in the Intercomp Operator's Manual provided with your SpeedTender.



# General Service

## Daily Service (5 -10 Hours of Use)

**NOTE: J&M recommends the following service to be performed daily (every 5-10 hours of use)**

1. Grease the conveyor bearings every 10 hours. Use only two pumps of grease per bearing.  
**NOTE: Excess lubrication of these bearings will result in premature failure.**  
**NOTE: The conveyor has four bearing that need greased (two at each end). See "Conveyor Service" on page 21.**
2. Check your belt for proper tracking every 10 hours of use and before every season. For steps to properly track your belt see "Adjusting Conveyor Belt Tracking" on page 22.  
**NOTE: When checking the belt for tracking you should empty out the conveyor clean out door. See "Cleaning out Collapsible Hopper and Conveyor" on page 15.**
3. Check hydraulic oil level.
4. Inspect for oil leaks and repair as appropriate.
5. Check all hoses, fittings, bolts, and hardware to make sure that they are secure and properly tightened.
6. Check engine oil level. See engine operator's manual for details on oil levels, oil types and service intervals.
7. Check SpeedTender brakes and lights before towing.
8. Check the SpeedTender periodically for cracks in welds and for other structural damage. Fix cracked welds immediately.  
**NOTE: Failure to have cracked welds fixed immediately could result in extensive damage to the SpeedTender and greatly reduce its life.**
9. Ensure tires are properly inflated. Tire care guidelines can be found in "Tire Service" on page 19.
10. Ensure wheel lug nuts are properly torqued. See "Bolt Torque Specifications" on page 10.
11. Ensure the conveyor hopper guard is in place. Do not remove.
12. Clean out the conveyor at the end of every day of use.

## End of the Year Service

**IMPORTANT: When the SpeedTender is not going to be used for a length of time, J&M recommends that you store the SpeedTender in a dry, protected place. Leaving your SpeedTender outside and open to the weather will shorten its life.**

1. Grease the conveyor bearings. Use only two pumps of grease per bearing.  
**NOTE: Excess lubrication of these bearings will result in premature failure.**  
**NOTE: The conveyor has four bearing that need greased (two at each end). See "Conveyor Service" on page 21.**
2. Grease pivot points on boom arm before storage.
3. The wheel bearings need to be cleaned, inspected, repacked, and adjusted. Use a number 2 wheel bearing grease to repack the bearings.
4. Inspect and service the brakes (magnets and shoes). They must be changed when they become worn or scored to prevent inadequate vehicle braking. Clean the backing plate, magnet arm, magnet, and brake shoes. Make certain all the parts removed are replaced in the same brake and drum assembly. Inspect the magnet arm for any loose or worn parts. Check shoe return springs, hold down springs, and adjuster springs for stretching or deformation and replace if required.
5. If equipped with talc, be sure to empty talc box entirely and run the talc auger to completely empty talc from the auger pipe.
6. Ensure wheel lug nuts are properly torqued. See "Bolt Torque Specifications" on page 10.
7. Ensure tires are properly inflated. Tire care guidelines can be found in "Tire Service" on page 19.
8. Remove all seed from inside the seed tanks.
9. Clean out the conveyor at the end of every season. See "Cleaning out Collapsible Hopper and Conveyor" on page 15.
10. Tension and track the conveyor belt. See "Adjusting Conveyor Belt Tracking" on page 22.
11. Check the SpeedTender periodically for cracks in welds and for other structural damage. Have cracked welds fixed immediately.  
**NOTE: Failure to have cracked welds fixed immediately could result in extensive damage to the SpeedTender and greatly reduce its life.**
12. Check hydraulic hoses for wear and replace if needed.
13. Ensure the conveyor hopper guard is in place.
14. Remove battery from the SpeedTender and place in a cool, dry place.  
**NOTE: Attaching a trickle charger to the battery will help ensure a long life for your battery.**  
**IMPORTANT: Be sure to disconnect the scales from the battery before charging.**
15. Change hydraulic oil filter element with either a NAPA 1552 or a FRAM P1654A Filter.
16. Top off hydraulic oil tank with good quality hydraulic AW 32 oil.  
**NOTE: If the hydraulic oil appears to be "milky" in color, it should be changed immediately. Otherwise, the hydraulic oil should be changed every 2-3 years. If the environment is extremely dusty or dirty the hydraulic oil should be changed more often.**
17. Check motor oil level. See engine operator's manual for details on oil levels, oil types, and service intervals.
18. Retract all hydraulic cylinders to prevent the piston rods from rusting.
19. Touch up spots where paint has worn away (use good quality primer paint - especially before applying graphite paint to the inside of the shell).

# General Service

## **Removing From Storage**

1. Grease the conveyor bearings. Use only two pumps of grease per bearing.  
**NOTE: Excess lubrication of these bearings will result in premature failure.**  
**NOTE: The conveyor has four bearings that need greased (two at each end). See “Conveyor Service” on page 21.**
2. Grease pivot points on boom arm.
3. Ensure wheel lug nuts are properly torqued. See “Bolt Torque Specifications” on page 10.
4. Ensure tires are properly inflated. Tire care guidelines can be found in “Tire Service” on page 19.
5. Check your belt for proper tracking every 10 hours of use and before every season. For steps to properly track your belt see “Adjusting Conveyor Belt Tracking” on page 22.  
**NOTE: When checking the belt for tracking you should empty out the conveyor clean out door. See “Cleaning out Collapsible Hopper and Conveyor” on page 15.**
6. Check oil level.
7. Inspect for hydraulic oil leaks and repair as appropriate.
8. Check all hoses, fittings, bolts, and hardware to ensure they are secure and properly tightened.
9. Check engine oil level. See engine operator’s manual for details on oil levels, oil types, and service intervals.
10. Check SpeedTender brakes and lights before each time you tow.
11. Ensure the conveyor hopper guard is in place.
12. Reattach battery and check to ensure it is fully charged.  
**IMPORTANT: Be sure to disconnect the scales from the battery before charging.**

# Hydraulic Power Service

## **Daily (every 5 hours of use):**

1. Check oil level.
2. Inspect for oil leaks and repair as necessary.
3. Check all hoses, fittings, bolts and hardware to ensure they are secure and properly tightened.
4. Check motor oil level. See engine operator’s manual for details on oil levels, oil types, and service intervals.

## **Once per season (every 20-25 hours of use):**

Change hydraulic oil filter element with either a NAPA 1552 or a FRAM P1654A Filter.

## **Every two to three years (every 75-80 hours of use):**

Drain oil reservoir and refill with clean, good quality hydraulic AW 32 oil. (It is not recommended to refill with tractor hydraulic oil).

## **Replacing hydraulic parts:**

Refer to “Silver Hydraulic Valve JM0029973” on page 56, “Gold Hydraulic Valve JM0080426” on page 58, or “Blue Hydraulic Valve JM0080825” on page 60 for proper part description and part number for replacement.

## **Purge air from system as follows:**

1. Disconnect the rod end clevis of all cylinders in a circuit and block up cylinders so the rod can completely extend and retract without contacting any other components.
2. Pressurize the system and maintain system at full pressure for at least 5 seconds after cylinder rods stop moving. Check that all cylinders have fully extended or retracted.
3. Check hydraulic reservoir and refill as needed.
4. Pressurize system again to reverse the motion of step 2. Maintain pressure on system for at least 5 seconds after cylinder rods stop moving. Check that cylinders have fully extended or retracted.
5. Check for hydraulic leaks using cardboard or wood.
6. Repeat steps 2, 3, 4 and 5 (3 to 4 times).
7. Depressurize hydraulic system and connect cylinder rod clevises to their mating lugs.

# Tire Service

## Tire Pressure

The following is to be used as a general guide for tire inflation. Figures can vary depending on specific brand of tire used. It is important that tires are inspected before and after unit is loaded. Start with the minimum pressure indicated. The tire should stand up with no side wall buckling or distress as tire rolls. Do not exceed maximum recommended tire pressure. **235-85-R16 tires are standard on the SpeedTender and should be inflated to 80 psi.** J&M also recommends rotating your tires front to back (not side to side) every 1,200 miles or 12 months (whichever comes first) for longer tire life. The image below is a troubleshooting chart used to ensure the tires wear evenly.

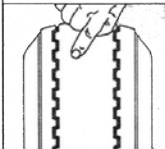
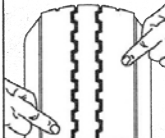
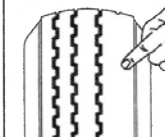
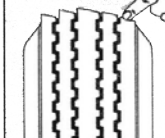
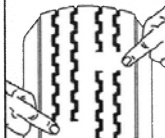
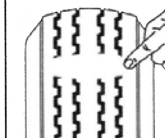
	Condition	Possible Cause	Remedy
	Even Center Wear	Over Inflation	Check & Adjust Pressure When Cold
	Inside & Outside Wear	Under Inflation	Check & Adjust Pressure When Cold
	Smooth, Side Wear - One Side	Loss of Camber or Overloading	Check & Unload As Necessary Have Alignment Checked
	"Feathering" Across The Face	Axle Not Square To Frame or Incorrect Toe In	Square Axles Have Alignment Checked
	Cupping	Loose Bearings or Wheel Balance	Check Bearing Adjustment and Wheel & Tire Balance
	Flat Spots	Wheel Lockup	Adjust Brakes

## Tightening Lug Nuts

Torque 9/16"-18 lug nuts on wheels to 170 ft-lbs after the first 10, 25, and 50 miles of driving, then recheck torque every 50 hours or every year, whichever comes first. Failure to do so may damage wheel nut seats. Once seats are damaged, it will become impossible to keep nuts tight.

# Wheel Bearing Service

Clean, inspect, and repack the wheel bearings every 12 months or 12,000 miles. Use a number 2 wheel bearing grease to repack the bearings.

## Bearing Inspection and Service:

1. Jack up SpeedTender.
2. Remove wheel lug nuts.
3. Remove wheel from hub.
4. Remove grease cap.  
**NOTE: Be careful not to dent or cut a hole in grease cap.**
5. Remove the cotter pin, nut, and washer.
6. Wiggle the hub to take the outer wheel bearing out.
7. Pull hub assembly straight off the axle. If you want to reuse the grease seal, (which is not recommended), be careful to support the weight of the hub so that the end of the axle does not ruin the rubber part of the grease seal.
8. To remove the inner bearing, you must remove the grease seal.
9. Remove inner bearing.
10. Wash all grease and oil from the bearing cone using a suitable solvent. Dry the bearing with a clean, lint-free cloth and inspect each roller completely. If any pitting, scalding, or corrosion is present, then the bearing must be replaced. The bearing cups inside the hub must be inspected.  
**NOTE: Bearings must always be replaced in sets of a cone and a cup.**
11. Repack inner bearing with new grease.
  - A. Place a moderate amount of grease in the palm of one hand.
  - B. Hold the inner bearing, large side down, in your other hand.
  - C. Using the edge of the bearing like an ice cream scoop, work it in until you see fresh grease come out of the top side of the bearing.
  - D. Rotate 1/8 of a turn and repeat until the whole bearing is full of fresh grease.
12. Place the inner bearing in the back of the wheel hub and add a liberal dose of grease.
13. Position the new wheel seal in its recess and lightly set it with a hammer.  
**NOTE: Be careful to not deform the metal part of the seal.**
14. Slide the hub assembly onto the spindle and push it back into position.
15. Grease the outer bearing by hand, repeating the procedure used with the inner bearing in step 11.
16. Slide the outer bearing and the spindle washer onto the spindle and into the hub recess.
17. Install and bottom out the spindle nut, then back it off 1/4 turn.
18. Reinstall the spindle nut and replace the cotter pin with a new one.  
**NOTE: If the castle nut does not line up with the hole in the spindle, then loosen the nut slightly until it does.**
19. Pack the bearing cap with fresh grease and lightly drive it into the hub recess with a hammer.
20. Reinstall the wheel onto the hub and torque the wheel lug nuts. See "Bolt Torque Specifications" on page 10.

## Bearing cup replacement:

1. Place the hub on a flat work surface with the cup to be replaced on the bottom side.
2. Using a brass drift punch, carefully tap around the small diameter end of the cup to drive it out.
3. After cleaning the hub bore area, replace the cup by tapping it with the brass drift punch. Be sure the cup is seated all the way up against the retaining shoulder in the hub.



# Conveyor Service

## Grease Conveyor Bearings

Grease the conveyor bearings every 10 hours of operation and before storage. Use only two pumps of grease per bearing.

**NOTE: Excess lubrication of these bearings will result in premature failure.**

**NOTE: The conveyor has four bearings that need grease (two at each end).**

## Grease Swing Arm

Grease pivot points on boom arm every 50 hours and before storage.

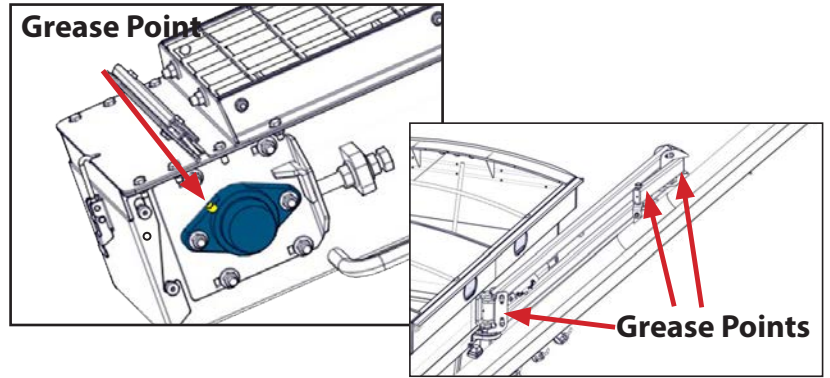

## Belt Tracking

Conveyor belt must run in the center of the pulley at both the discharge end and the collapsible hopper end. Failure to do so will lead to unnecessary wear and shortening of belt life. We recommend that you check your belt for proper tracking every 10 hours of use and before every season.

### **Checking the belt tracking at collapsible hopper end:**

1. Open clean out door located under collapsible hopper to see if the belt is centered on the pulley.
2. If the belt tracking is centered, close the clean out door. If tracking needs adjustment, "Adjusting Conveyor Belt Tracking" on the next page.

### **Checking the belt tracking at discharge end:**

1. Remove the 12 bolts located at the discharge end (as displayed in the diagram below).
2. Remove the discharge pan and rubber discharge pan to see if the belt is centered on the pulley.
3. If the belt tracking is centered, reinstall the head pan. If tracking needs adjustment, see "Adjusting Conveyor Belt Tracking" on the next page.

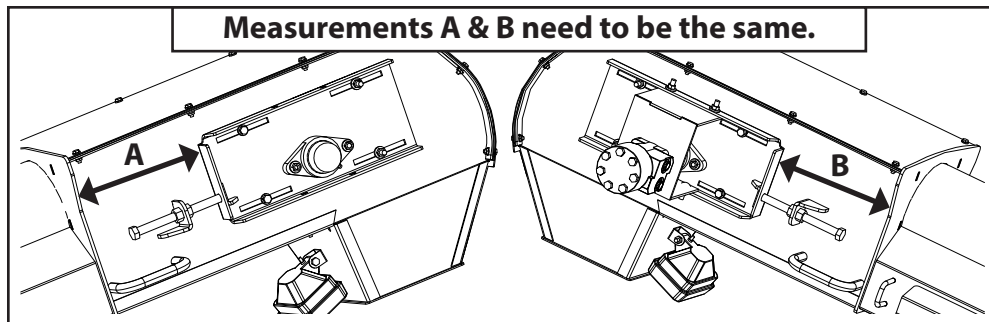
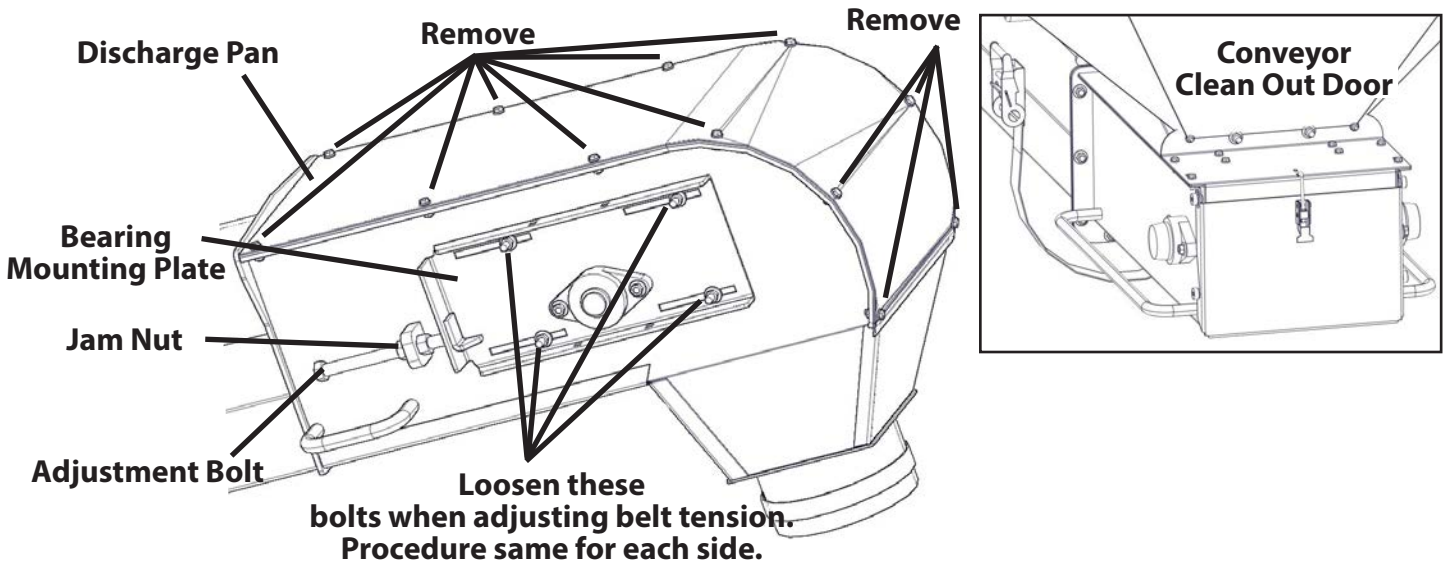

## **Adjusting Conveyor Belt Tracking**

1. Loosen, but do not remove, the four bolts on the two bearing mounting plates located at the collapsible hopper end of the conveyor (as shown in the picture below).

**NOTE: Only adjust conveyor in normal position, do not adjust in self-fill position.**

2. Operate the conveyor at a slow speed.

**⚠ CAUTION: Keep hands and clothing away from moving parts.**

Loosen jam nut on adjustment bolt.

3. Tighten the adjustment bolt slowly until belt is running in the center of the pulley.

**NOTE: Do not loosen the adjustment bolt.**

4. Tighten all bolts on bearing mounting plate as well as the jam nuts on the adjustment bolts.

5. Repeat at discharge end.

6. When belt is running in center of the pulley on both ends of conveyor, allow the SpeedTender to run for 10 minutes and recheck the belt for proper tracking.

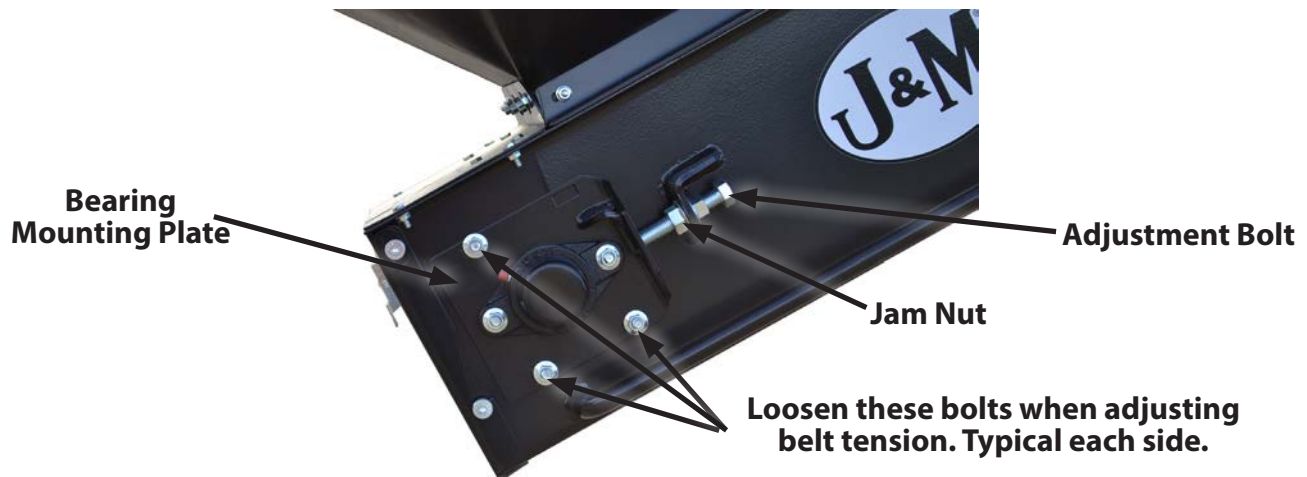

## **Belt Tensioning**

**NOTE: You need to adjust your belt tension at least once a year.**

1. Remove the head pan and head pan gasket.
2. Loosen, but do not remove, the four bolts on the two bearing mounting plates located at the discharge end of the conveyor.
3. Loosen jam nut on adjustment bolt at discharge end.
4. Torque threaded adjustment bolt to 23 ft-lbs.
5. Operate the conveyor at a slow speed.  
**⚠ CAUTION: Keep hands and clothing away from moving parts.**
6. If the belt is tracking properly go to next step. If tracking needs adjustment, see "Adjusting Conveyor Belt Tracking" above.
7. Open the clean out door located under collapsible hopper to see if the belt is centered on the pulley. If the tracking is centered, close the clean out door, tighten all hardware and go to next step. If tracking is off, see "Adjusting Conveyor Belt Tracking" above.
8. Run the belt at medium speed for 10 minutes and recheck the tracking at both the discharge and collapsible hopper end. If the belt is still tracking in the center of both pulleys, reinstall the head pan. If tracking needs adjustment, see "Adjusting Conveyor Belt Tracking" above.

# Brakes Service

The SpeedTender is equipped with electric brakes. They need to be inspected and serviced immediately if a loss of performance is experienced. You need to service your SpeedTender brakes at least once a year with normal use.

## **How to use your electric brakes properly:**

Your SpeedTender brakes are designed to work in synchronization with your tow vehicle brakes. Never use your tow vehicle or SpeedTender brakes alone to stop the combined load.

Your SpeedTender and tow vehicle will seldom have the correct amperage flow to the brake magnets to give you comfortable, safe braking unless you make proper brake system adjustments. Changing trailer load and driving conditions, as well as uneven alternator and battery output, can mean unstable current flow to your brake magnets. It is therefore imperative that you maintain and adjust your brakes as set forth in this manual, use a properly modulated brake controller, and perform the synchronization procedure noted below. In addition to the synchronization adjustment detailed below, electric brake controllers provide a modulation function that varies the current to the electric brakes with the pressure on the brake pedal or amount of deceleration of the tow vehicle. It is important that your brake controller provide approximately 2 volts to the braking system when the brake pedal is first depressed and gradually increases the voltage to 12 volts as brake pedal pressure is increased. If the controller “jumps” immediately to a high voltage output, even during a gradual stop, then the electric brakes will always be fully energized and will result in harsh brakes and potential wheel lockup.

## **To synchronize:**

To ensure safe brake performance and synchronization, read the brake controller manufacturer’s instruction completely before performing the synchronization procedure.

Make several hard stops from 20 mph on a dry, paved road that is free of sand and gravel. If the SpeedTender brakes lock and slide, decrease the gain setting on the controller. If they do not slide, slightly increase the gain setting, Adjust the controller just to the point of impending brake lockup and wheel skid.

## **How to adjust electric brakes:**

1. Park the SpeedTender on firm and level ground.
2. Block the trailer tires on the opposite side securely so that no forward or rearward movement is possible.
3. Jack up the SpeedTender.
4. Secure the front and rear of the trailer on jack stands of adequate capacity.
5. At the back of the wheel, on the brake backing plate, there is a small rubber plug near the bottom of the backing plate. Pry out this plug to give access to the star wheel adjuster.
6. Insert the brake adjuster tool and maneuver it so that the tool engages with the teeth in the star wheel. The star wheel looks like a gear with exposed teeth on the perimeter.
7. Turn the adjuster until the brake locks up (you can no longer rotate the wheel by hand). This centers the brake shoes on the brake drum in the correct position.
8. Back off the star wheel 8-10 clicks or as specified by the manufacturer. The wheel should spin freely with no apparent drag to slow it down. A slight scraping noise is normal as the wheel turns.
9. Repeat this procedure for all the wheels.

## **When to adjust brakes:**

1. After the first 200 miles of operating when the brake shoes and drums have “seated.”
2. At 3,000 mile intervals or once a year, whichever comes first.

## **Brake Cleaning and Inspection:**

Your SpeedTender brakes must be inspected and serviced at yearly intervals, (or more often as use and performance requires). Magnets and shoes must be changed when they become worn or scored, which causes inadequate vehicle braking. Clean the backing plate, magnet arm, magnet, and brake shoes. Make certain all the parts removed are replaced in the same brake and drum assembly. Inspect the magnet arm for any loose or worn parts. Check shoe return springs, hold down springs, and adjuster springs for stretching or deformation and replace if required.

# Brakes Service

## Brake Shoe and Lining Inspection:

A simple visual inspection of your brake linings will tell if they are usable. Replacement is necessary if the lining is worn (to within 1/16" or less), contaminated with grease or oil, or abnormally scored or gouged. Hairline heat cracks are normal in bonded linings and should not be cause for concern. When replacement is necessary, it is important to replace both shoes on each brake and both brakes of the same axle. This will help retain the "balance" of your brakes.



**Acceptable  
Hairline Cracks**

## Replacing Brake Linings:

1. Remove the brake shoe retract spring.
2. Remove the shoe hold down assembly by holding the back of the pin with one hand and pushing against the spring and twisting with a hold down spring tool until the cup is released.
3. Remove both shoes together leaving the adjuster assembly and spring intact.
4. Clean the backing plate and lever arm.
5. Inspect magnet arm for any loose or worn parts.
6. Replace springs that are broken, bent, or weak.
7. Apply a light film of lubricant to the anchor pin and shoe rest pads & backing plate areas that are in contact with the lever arm.
8. Attach the adjuster screw and spring to the new brake shoes. The star wheel and adjuster must be positioned as before.
9. Install the new shoes on the backing plate and reinstall shoe retract spring.

After replacement of brake shoes and linings, the brake must be re-burnished to seat in the new components. This should be done by applying the brakes 20-30 times from an initial speed of 40 mph, slowing the vehicle to 20 mph. Allow ample time for brakes to cool between applications. This procedure allows the brake shoes to seat into the drum surface.

## Brake Lubrication:

Before reassembling, apply a light film of lubrication or similar grease, or anti-seize compound on the brake anchor pin, the actuating arm bushing and pin, and the areas of the backing plate that are in contact with the brake shoes and magnet lever arm. Apply a light film of grease on the actuating block mounted on the actuating arm.

## Troubleshooting:

Mechanical causes are ordinarily obvious, bent or broken parts, worn out linings or magnets, seized lever arms or shoes, scored drums, loose parts, etc. Most electric brake malfunctions that cannot be corrected by either brake adjustments or synchronization adjustments can generally be traced to electrical system failure. Voltmeter and ammeter are essential tools for proper troubleshooting of electric brakes.

## How to Measure Voltage:

System voltage is measured at the magnets. Connect the voltmeter to the two magnet lead wires at any brake. This may be accomplished by using a pin probe inserted through the insulation of the wires dropping down from the chassis or by cutting the wires. **The engine of the towing vehicle should be running when checking the voltage (so that a low battery will not affect the readings).**

## Brake Magnet Inspection:

Your electric brakes are equipped with high quality electromagnets that are designed to provide the proper force and friction. Your magnets should be inspected and replaced if worn unevenly or abnormally (as shown below). Even if wear is normal as indicated by your straightedge, the magnets should be replaced if any part of the magnet coil has become visible through the friction material facing of magnet. It is also recommended that the drum armature surface be re-faced when replacing magnets. Magnets should also be replaced in pairs - both sides of an axle.

### Straight Edge

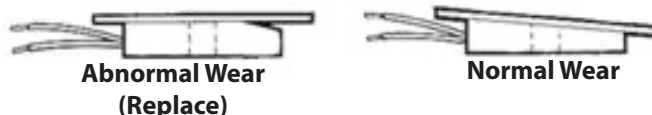



# Brakes Service

Voltage in the system should begin at 0 volts. As the controller bar is slowly actuated, the voltage should gradually increase to approximately 12 volts, which is referred to as modulation. No modulation means when the controller begins to apply voltage to brakes, it applies an immediate high voltage, which causes the brakes to apply instantaneous maximum power.

The threshold voltage of a controller is the voltage applied to the brakes when the controller first turns on. The lower the threshold voltage, the smoother the brakes will operate. Threshold voltage in excess of 2 volts (quite often found in heavy duty controllers) can cause grabbing, resulting in harsh braking.

## How to Measure Amperage:

System amperage is the amperage being drawn by all brakes on the trailer. **The engine of the towing vehicle should be running when checking amperage.**

Measure system amperage on the blue wire of the controller, which is the output to the brakes. The blue wire must be disconnected and the amp meter put in series into the line. System amperage draw should be as noted in the table below. Make sure your ammeter has sufficient capacity and note polarity to prevent damaging your amp meter.

Brake Size	Amps/Magnet	Two Brakes	Four Brakes	Six Brakes	Magnet Ohms
12 X 2	3.0	6.0	12.0	18.0	3.2

## Replacing brake magnet:

1. Orient the magnet over the lever arm post such that the magnet leads are in the correct position for routing.
2. Push the magnet over the lever arm post by compressing the magnet spring between the magnet and the lever arm.
3. Insert the magnet clip in the slot of the magnet. Be sure to orient the magnet clip so it will "snap" into place.
4. Press down on the magnet and install the magnet clip.
5. Be sure that the magnet moves up and down freely on the lever arm post.
6. Route the wiring in the same manner noted on removal. Be sure that wires cannot bind, pinch, or rub. Manually actuate lever arm to ensure there is no interference.
7. Install strain relief bushing, allowing enough slack in the wiring to allow the lever arm to move without straining the wires. Be sure the wire cannot come in contact with the armature.
8. Connect the magnet leads to the trailer wiring harness and then reinstall hub and drum.

## Brake Drum Inspection:

There are two areas of the brake drum that are subject to wear and require inspection. These two areas are the drum surface where the brake shoes make contact during stopping and the armature surface where the magnet contacts (only in electric brakes).

The drum surface should be inspected for excessive wear or heavy scoring. If worn more than .020" oversized, or if the drum has worn out of round by more than .015", then the drum surface should be turned. If scoring or other wear is greater than .090" on the diameter, the drum must be replaced. When turning the drum surface, the maximum re-bore diameter for a 12" brake drum is 12.090"

The machined inner surface of the brake drum that contacts the brake magnet is called the armature surface. If the armature surface is scored or worn unevenly, it should be refaced to a 120 micro inch finish by removing not more than .030" of material. To ensure proper contact between the armature face and the magnet face, the magnets should be replaced whenever the armature surface is refaced. The armature surface should be refaced whenever the magnets are replaced.

# Troubleshooting

Problems	Solutions
Unit sways during travel	<ul style="list-style-type: none"> <li>a. Check tire pressure.</li> <li>b. Check tow vehicle for loosened hitch parts.</li> <li>c. Check tow vehicle's hitch height.</li> <li>d. Reduce towing speed.</li> <li>e. Check wheel lug nuts.</li> <li>f. Check wheel bearings for adjustment (see "Wheel Bearing Service" on page 20).</li> </ul>
Tires show excessive wear	<ul style="list-style-type: none"> <li>a. Check tire pressure.</li> <li>b. Rotate tires (see "Tire Service" on page 19).</li> <li>c. Check wheel bearings for adjustment (see "Wheel Bearing Service" on page 20).</li> </ul>
Wheel makes grinding or squeaking noise	<ul style="list-style-type: none"> <li>a. Service wheel bearings (see "Wheel Bearing Service" on page 20).</li> </ul>
Noisy when brakes are being applied	<ul style="list-style-type: none"> <li>a. Properly adjust brakes.</li> <li>b. Replace any weak or broken springs in brakes.</li> <li>c. Replace the brake linings if excessively worn or contaminated.</li> <li>d. Check wheel bearings for adjustment (see "Wheel Bearing Service" on page 20).</li> </ul>
No brakes	<ul style="list-style-type: none"> <li>a. Properly adjust brakes.</li> <li>b. Check for short in electric circuit.</li> <li>c. Replace any brake magnets that are worn or defective.</li> </ul>
Weak brakes	<ul style="list-style-type: none"> <li>a. Properly adjust brakes.</li> <li>b. Replace any excessively worn or contaminated linings.</li> <li>c. Check for short in electric circuit.</li> <li>d. Replace bent backing plate.</li> </ul>
Dragging brakes	<ul style="list-style-type: none"> <li>a. Properly adjust brakes.</li> <li>b. Replace any weak or broken springs in brakes.</li> </ul>
Locking brakes	<ul style="list-style-type: none"> <li>a. Replace any weak or broken springs in brakes.</li> <li>b. Replace any excessively worn or contaminated linings.</li> </ul>
Grabbing brakes	<ul style="list-style-type: none"> <li>a. Replace any excessively worn or contaminated linings.</li> </ul>
Surging brakes	<ul style="list-style-type: none"> <li>a. Trailer is not adequately grounded.</li> </ul>
Belt is not moving - Hydraulic pump is not producing sufficient pressure or volume to belt motor	<ul style="list-style-type: none"> <li>a. Check for pinched or leaking hydraulic line.</li> <li>b. Allow hydraulic oil to warm up.</li> <li>c. Increase engine RPM.</li> <li>d. Charge battery or plug in to tow vehicle.</li> <li>e. Hydraulic fluid level low.</li> <li>f. Hydraulic filter clogged.</li> <li>g. Check for proper oil viscosity.</li> <li>h. Check hydraulic output pressure.</li> </ul>
Belt is not moving - Obstructed conveyor	<ul style="list-style-type: none"> <li>a. Ensure conveyor is not clogged.</li> </ul>
Belt has insufficient output speed or RPM - Hydraulic pump is not producing sufficient pressure or volume to belt motor	<ul style="list-style-type: none"> <li>a. Check for pinched or leaking hydraulic lines.</li> <li>b. Allow hydraulic oil to warm up.</li> <li>c. Increase engine RPM.</li> <li>d. Hydraulic fluid level low.</li> <li>e. Hydraulic filter clogged.</li> <li>f. Check for proper oil viscosity.</li> <li>g. Repair or replace worn out pump.</li> </ul>
Belt has insufficient output speed or RPM - Belt is slipping	<ul style="list-style-type: none"> <li>a. Adjust belt tension and tracking (see "Adjusting Conveyor Belt Tracking" on page 22).</li> <li>b. Check telescoping spout and conveyor for a clog.</li> <li>c. Remove material from clean out door.</li> </ul>
Belt has insufficient output speed or RPM - Air in hydraulic system	<ul style="list-style-type: none"> <li>a. Bleed air out of hydraulic system and fill reservoir (see "Hydraulic Power Service" on page 18).</li> <li>b. Look for leaking or cracked fittings.</li> </ul>
Belt has insufficient output speed or RPM - Leak in motor, valve body, or bypass valves	<ul style="list-style-type: none"> <li>a. Replace or repair motor, valve body, or bypass valves.</li> <li>b. Check for proper oil viscosity.</li> <li>c. Clean and lubricate the brake assemblies.</li> </ul>
Excessive wear to belt edge - Tracking is off	<ul style="list-style-type: none"> <li>a. Adjust belt tension and tracking (see "Adjusting Conveyor Belt Tracking" on page 22).</li> </ul>

# Troubleshooting

Problems	Solutions
Excessive wear to belt edge - Rubber skirting is worn or out of place	a. Replace rubber skirting.
	b. Adjust rubber skirting.
Swing arm will not move up or down - Engine RPM slow	a. Increase engine RPM.
Swing arm will not move up or down - Hydraulic pump is not producing sufficient pressure or volume to hydraulic cylinder	a. Check for pinched or leaking hydraulic lines.
	b. Allow hydraulic oil to warm up.
	c. Increase engine RPM.
	d. Hydraulic fluid level low.
	e. Hydraulic filter clogged.
	f. Check for proper oil viscosity.
	g. Check if hydraulic pump is worn out.
	h. Ensure battery is fully charged.
	i. Check wiring to valve body and hydraulic pump.
Hydraulic unit squeals	a. Check sight glass on hydraulic unit reservoir and fill if necessary.
	b. Run engine at reduced speed for 5-10 minutes to warm up oil.
	c. Clean/replace filler cap/breather.
	d. Clear obstruction in suction hose.
	e. Replace plugged/dirty oil filter element.
Hydraulic unit has poor performance at high RPM	a. Clean pressure relief in control valve or replace.
	b. Check sight glass on hydraulic unit reservoir and fill if necessary.
	c. Replace plugged/dirty oil filter element.
	d. Charge battery.

# Valve Wiring

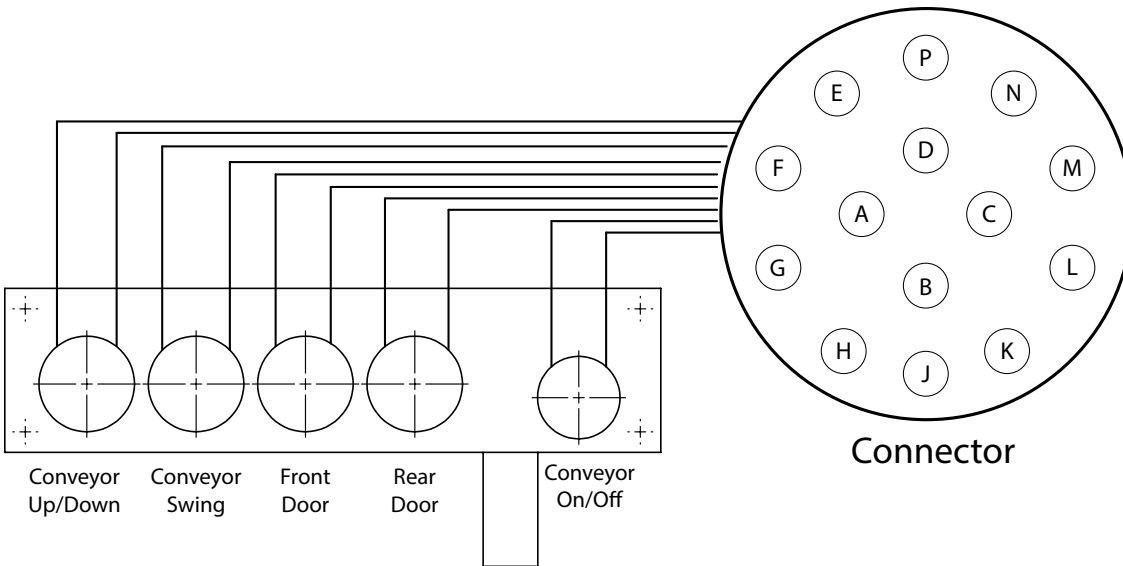

Letter	Function
A	N/A
B	N/A
C	Conveyor Swing Front
D	Conveyor Swing Rear
E	Conveyor Up
F	Conveyor Down
G	Rear Door Up
H	Front Door Down
J	Power
K	Front Door Up
L	Rear Door Down
M	N/A
N	Conveyor Start
P	Ground

- Use a good set of Allen wrenches when changing orifices.
- The cartridge should be tightened with 25 ft-lbs of torque.
- The coil nut should be tightened with 5 ft-lbs of torque.
- There is a spring, poppet valve, and ball bearing at the bottom of each coil.
- The top coil operates the bottom port.
- The bottom coil operates the top port.
- When changing cartridge make sure all functions are at rest.
- The lettering on the coils should always be facing up.

## Valve Bank Harnesses

The image on the right shows the valve bank harness (JM0041057) that is used on black, gold, blue, and silver 2014 and newer valve banks. It also shows what the connectors are for.

The harness on the left (JM0073932) is only used on units with the Intercomp or WC3 remote.

Silver valve banks will have the harness tied directly to it.

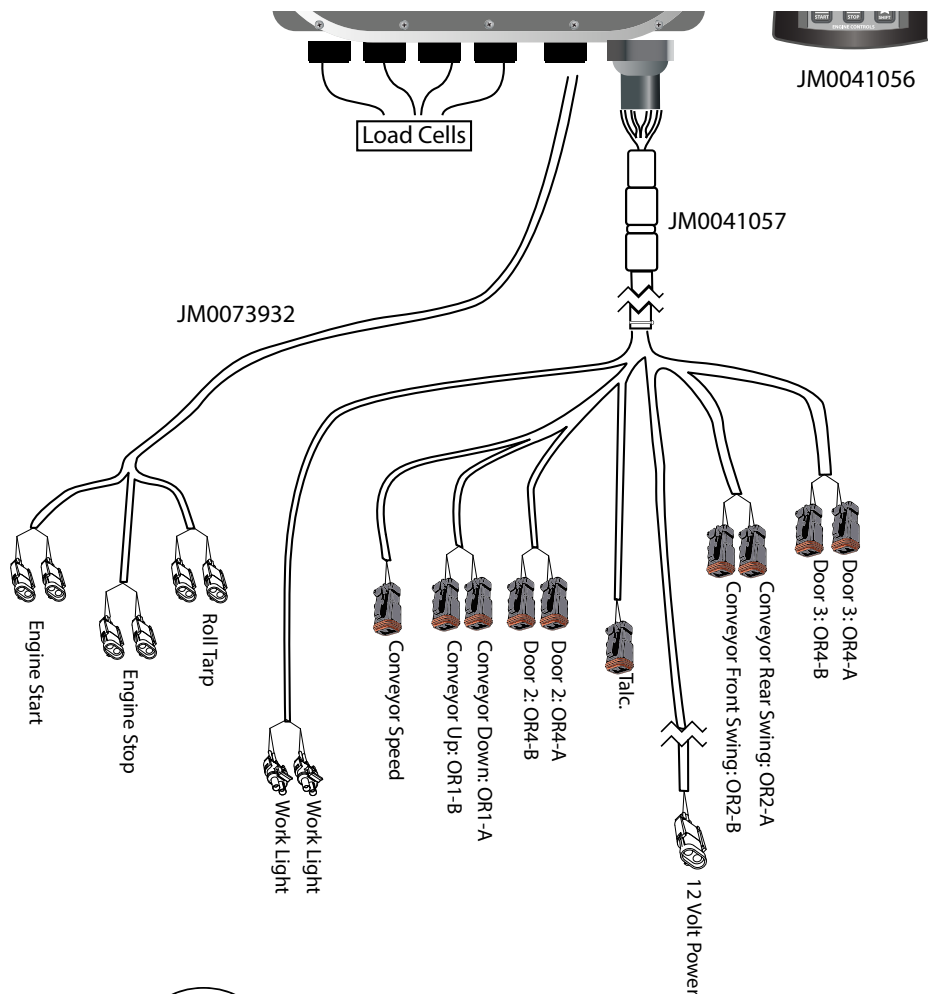

# Throttle Control for Kar-Tech

## ***Remote Speed Control for Kar-Tech Remotes***

The remote throttle option for the Kar-Tech Wireless System only works with the wireless J&M Mega Remote. This remote and receiver combination provides the output required to drive the throttle control via the 2-wire Deutsch connection. Press the up navigation button on the remote to increase the throttle. Press the down navigation button to decrease the throttle. Both buttons will only be activated when the conveyor is running.

**NOTE:** Remote throttle control is not available when the user is setting up Auto Dispense weight and door selection in the remote.



**REMOTE SPEED CONTROL INSTALLED**

In order to adjust the throttle, the wireless receiver and remote must be on.

**Instructions**

Press and hold **1** to INCREASE throttle.  
Press and hold **2** to DECREASE throttle.

# Wired Controls and Scale Monitor

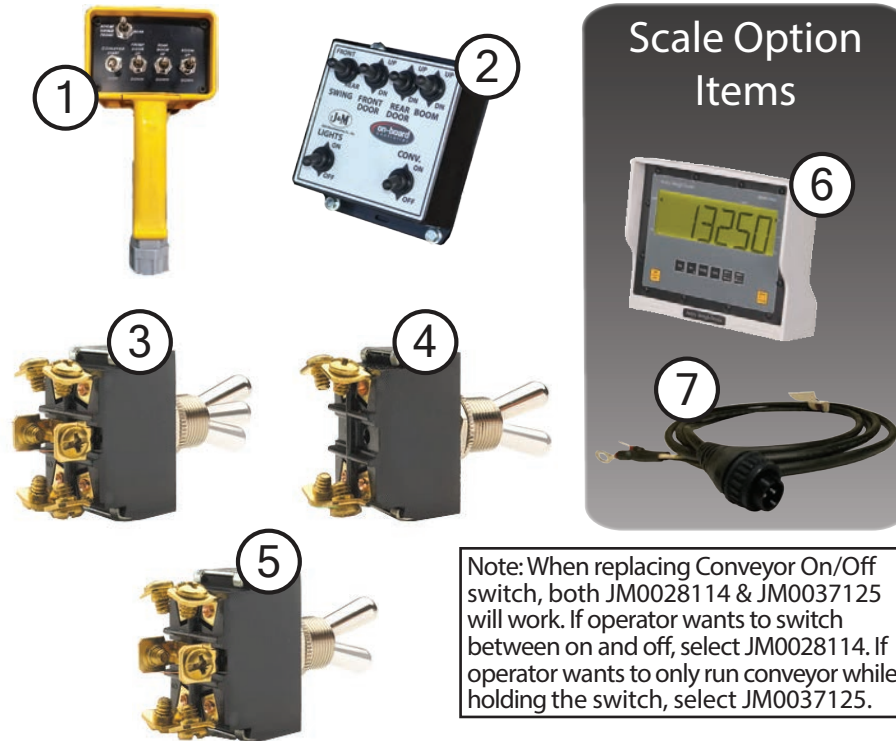

Note: When replacing Conveyor On/Off switch, both JM0028114 & JM0037125 will work. If operator wants to switch between on and off, select JM0028114. If operator wants to only run conveyor while holding the switch, select JM0037125.

	Description	Part No.
1	5 Switch Yellow Remote with 44' Cord (SPT-AF2)	JM0014991
2	Onboard Controller (LC Series and c450)	JM0051370
3	DPDT On-Off-On Switch (Three Position Switch)	JM0037124
4	DPST On-Off Switch (Two Position Throw Switch)	JM0028114
5	DPDT On-On (Momentary Switch - Must Hold Switch to Stay On)	JM0037125
6	Avery Weigh-Tronix 640XL Indicator (640XLI)	JM0007293
7	Avery Weigh-Tronix 640XL Power Cord for SpeedTender	JM0018867

# Kar-Tech Wireless Controls and Scale Monitor

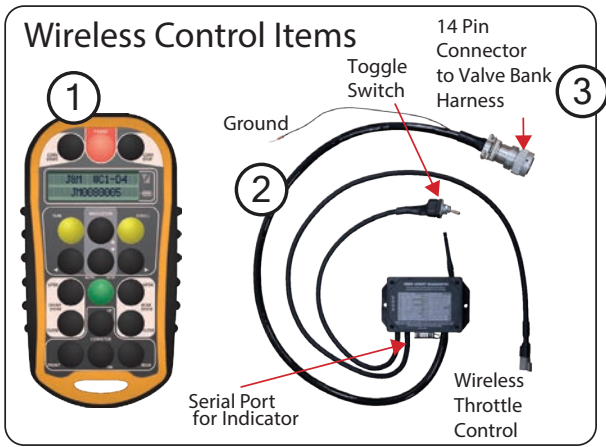

## Throttle Control Option for Kar-Tech Remotes

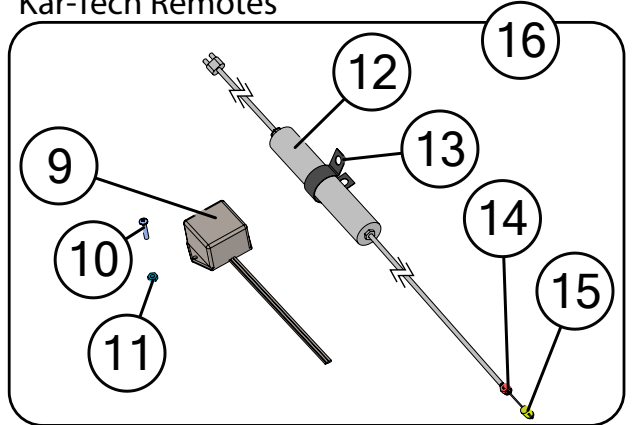

On-Board Controller

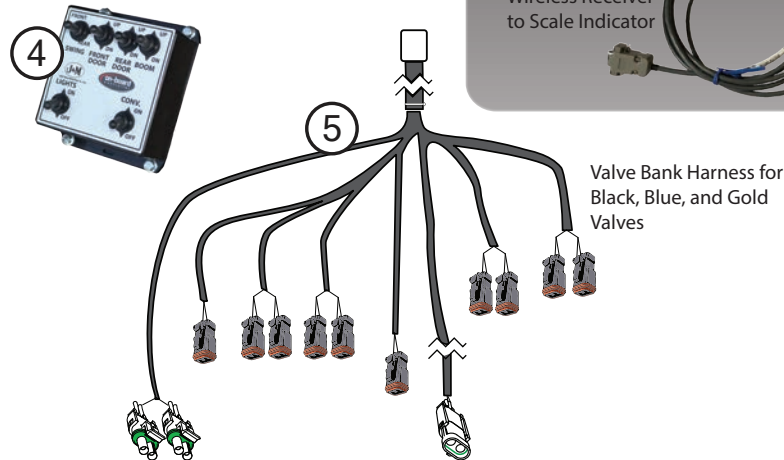

Description	Part No.
1 WC1-D4-R (2x Yellow) LC Series Wireless Remote	JM0080005
2 WC1-D4-I (2x Yellow) LC Series Wireless Receiver	JM0080004
3 WC1-D4 (2x Yellow) LC Series Wireless Kit	JM0080003
4 Onboard Controller (LC Series and c450)	JM0051370
5 Valve Bank Harness for Black, Gold and Blue (SpeedTender)	JM0041057
6 Avery Weigh-Tronix 640XL Indicator (640XLI)	JM0007293
7 Avery Weigh-Tronix 640XL Power Cord for SpeedTender	JM0018867
8 10' PC Interface Cable	JM0015402
9 Adapter for Kar-Tech Receiver - Throttler Control (113991)	JM0038428
10 #10-24 x 1" Z Round Head Phillips Screw	JM0037646
11 #10-24 Z Nylon Locking Hex Nut	JM0016030
12 RMC 3500 Linear Motor	JM0038427
13 Throttle Control Motor Tube Clamp	JM0038430
14 Cable Coupler w/ C-Clip	JM0041943
15 Throttle Wire Barrel w/ Screw for Seed Tender Throttle Control	JM0045232
16 Optional Speed Control For WC1-D3 Remote (2017 And Newer)	JM0040893

# Intercomp Wireless Controls and Scale Monitor

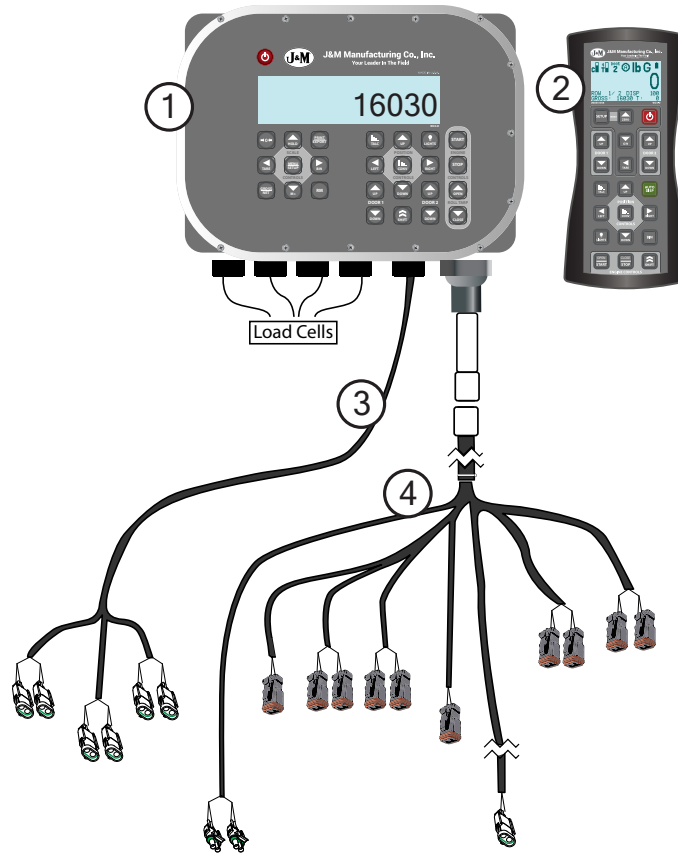

	Description	Part No.
1	Onboard Intercomp Controller (WC3-D)	JM0041055
2	Intercomp Remote	JM0041056
3	WC3-D Engine Accessory Harness	JM0073932
4	Valve Bank Harness for Black, Gold and Blue (SpeedTender)	JM0041057

## Battery Disconnect

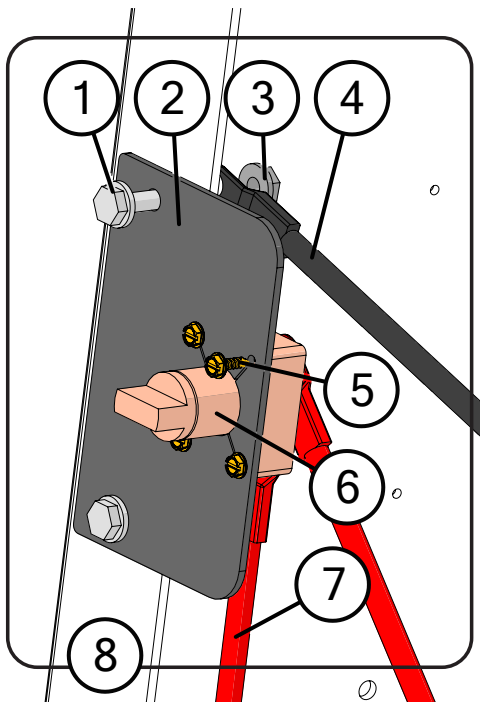

	Description	Part No.
1	1/4"-20 x 3/4" Gr5 Z SF Hex Bolt	JM0001642
2	Battery Disconnect Mount	JM0061073
3	1/4"-20 Gr5 Z SF Hex Nut	JM0001630
4	Battery Cable Ground	JM0081745
5	#6 x 1/2" Self Tapping Screw	JM0085325
6	Battery Disconnect Switch	JM0053441
7	Battery Disconnect Cable (96")	JM0054583
8	Complete Battery Disconnect Assembly	JM0054599





# Lights and Wiring

This table will be used for the following section, Lights and Wiring, on Pages 33-35:

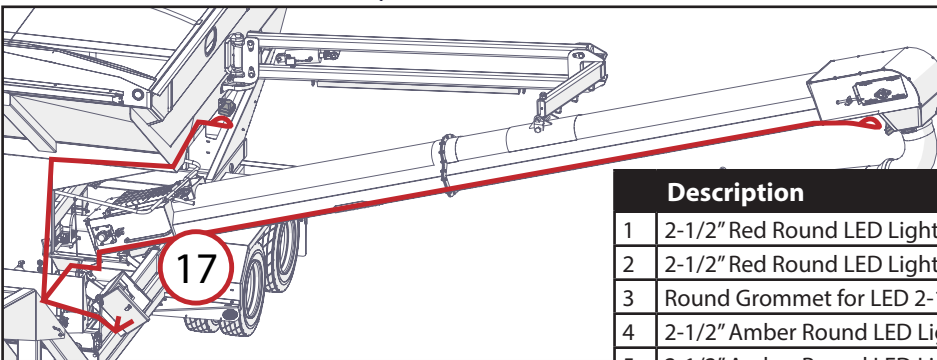
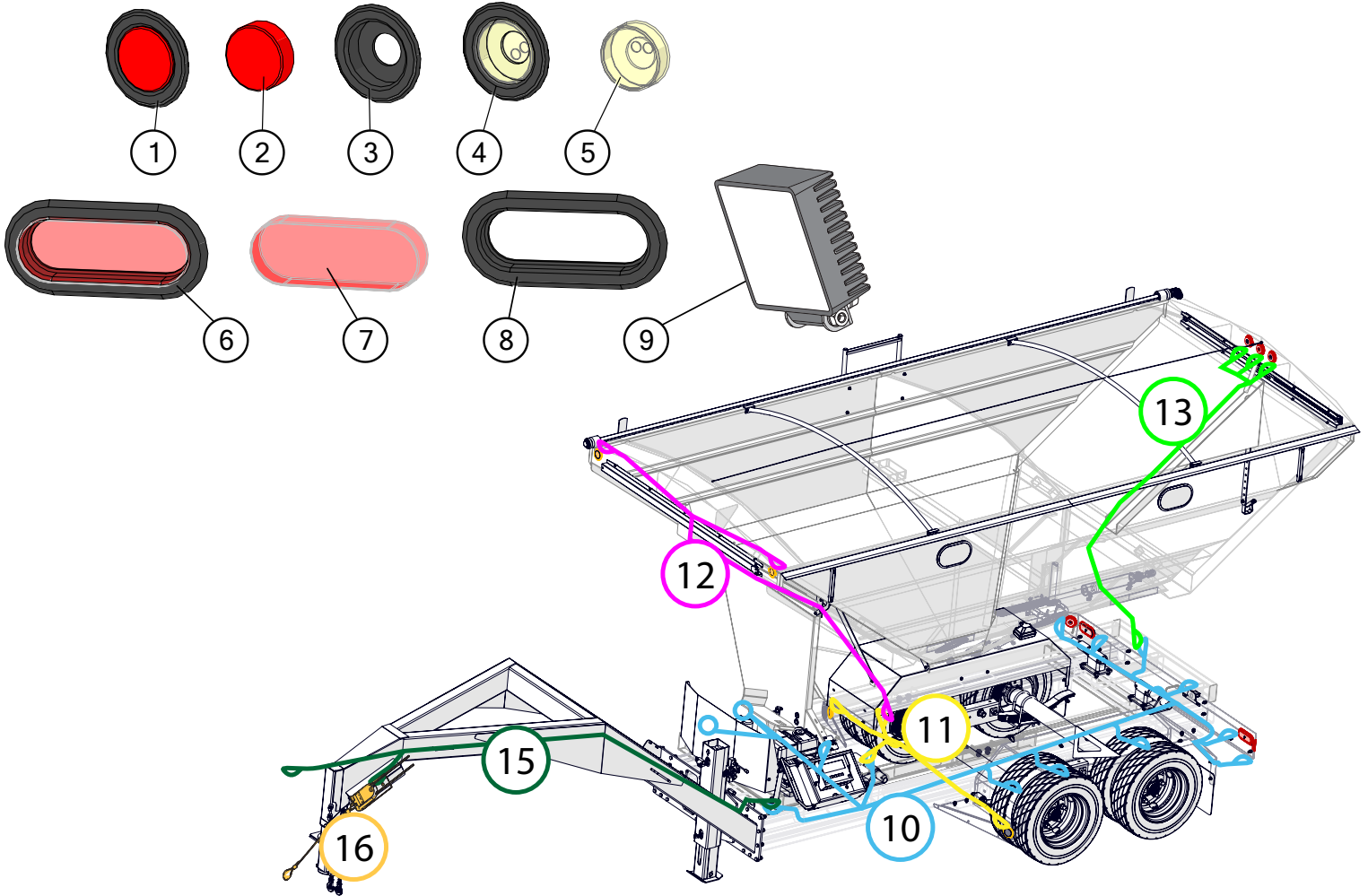

	Description	Part No.
1	2-1/2" Red Round LED Light/Reflector Assembly (RRLA1)	JM0001905
2	2-1/2" Red Round LED Light/Reflector (RRLR1)	JM0001901
3	Round Grommet for LED 2-1/2" Light/Reflector	JM0001902
4	2-1/2" Amber Round LED Light/Reflector Assembly (ARLA1)	JM0001908
5	2-1/2" Amber Round LED Light/Reflector	JM0001895
6	Red Oval Brake Light LED Assembly (BLSTOA1)	JM0001903
7	Red Oval Brake Light LED (BLSTOL1)	JM0007114
8	Oval Grommet for Brake Light LED (OVLG1)	JM0001897
9	LED Field Light with Weather Pack Connectors (SpeedTender, NitroGro)	JM0050942
10	ST Main Harness (419-475)	JM0033700
11	ST Front Chassis Wiring Harness (419-385)	JM0019963
12	ST Front Top Lights Harness (419-380)	JM0020364
13	ST Rear Top Lights Harness (419-390)	JM0019964
14	V-Belt A-Frame 7-Way Trailer Connection	JM0046142
15	V-Belt Gooseneck 7-Way Trailer Connection	JM0046143
16	Breakaway Switch with Cable (BAS-1)	JM0001843
17	ST Flood Light Harnesses (Sold As A Pair) (419-410)	JM0019965

# Lights and Wiring

## 10 ST Main Harness (419-475) (JM0033700)

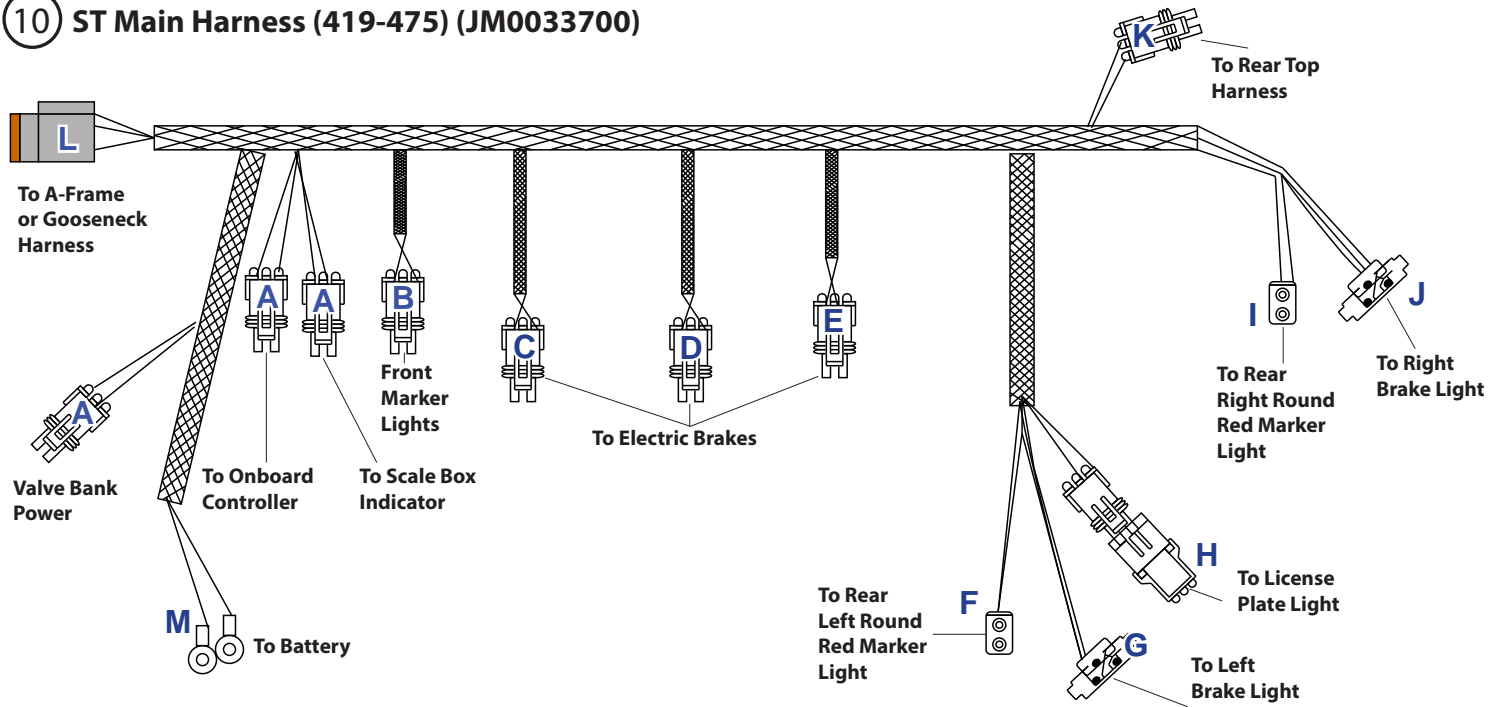

## 11 ST Front Chassis Wiring Harness (419-385) (JM0019963)

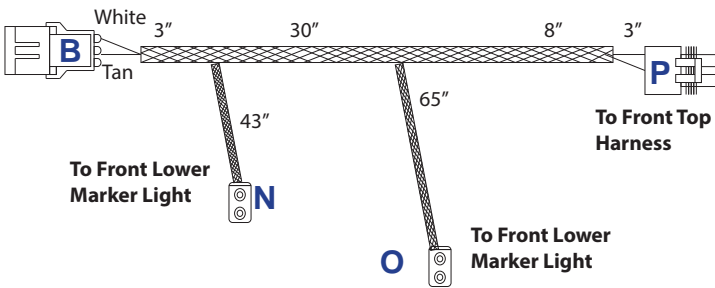

## 12 ST Front Top Lights Harness (419-380) (JM0020364)

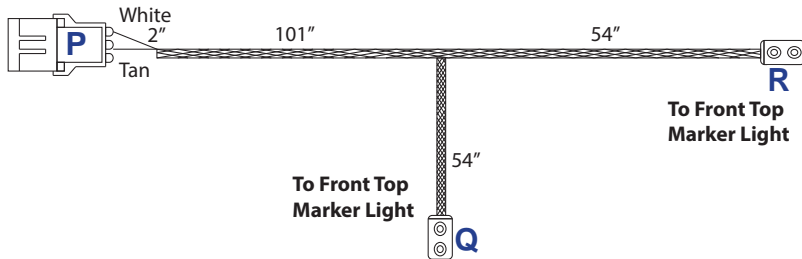

## 13 ST Rear Top Lights Harness (419-390) (JM0019964)

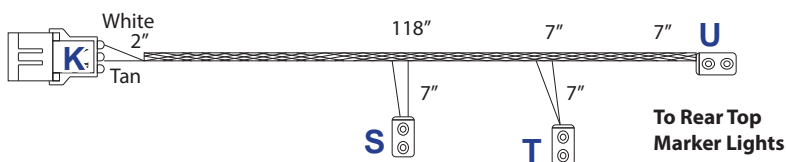

# Lights and Wiring

## 15 V-Belt Gooseneck 7-Way Trailer Connection (JM0046143)

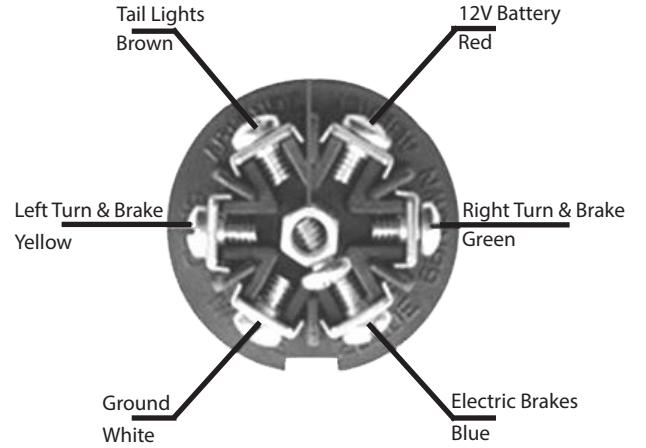
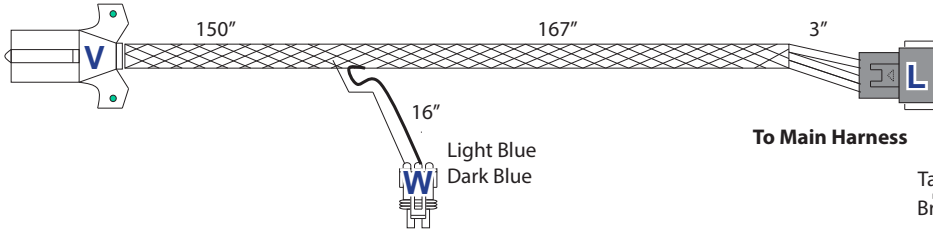

## 16 Breakaway Switch with Cable (BAS-1) (JM0001843)

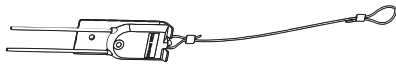

## 17 ST Flood Light Harnesses (419-410) (JM0019965)

To Onboard Controller

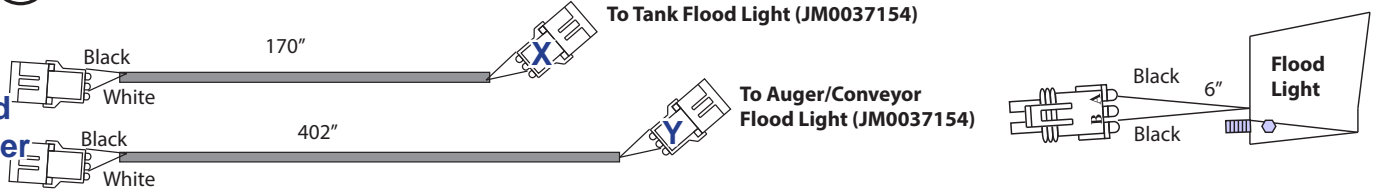

## Scale Wiring

Scale Display/ Interface

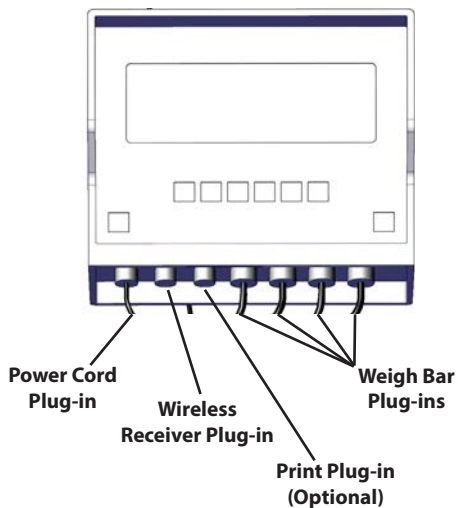

# Scale Display Box

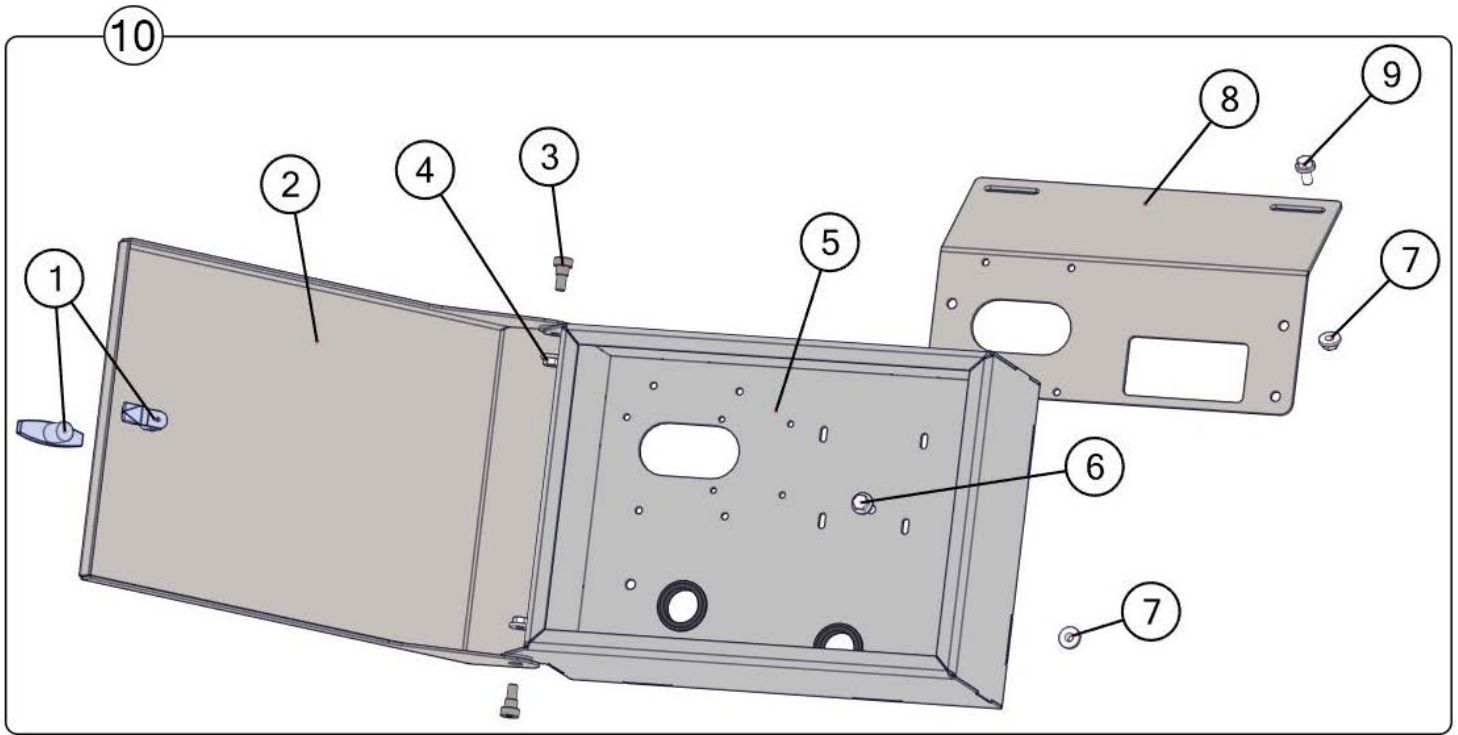

	Description	Part No.
1	Chrome T-Handle Non-Locking	JM0001911
2	Seed Tender Scale Box Door (LC Series)	JM0046652
3	1/2" Shoulder Dia x 3/8" Shoulder Length x 3/8"-16 Socket Shoulder Bolt	JM0009998
4	3/8"-16 Gr2 Z Centerlock Hex Nut	JM0001512
5	Seed Tender Scale Box	JM0046678
6	3/8"-16 x 1" Gr5 Z SF Hex Bolt	JM0002092
7	3/8"-16 Gr5 Z SF Hex Nut	JM0002152
8	Seed Tender Scale Mount Bracket	JM0031823
9	3/8"-16 x 3/4" Gr5 Z SF Hex Bolt	JM0001750
10	Seed Tender Scale Box Assembly	JM0029945

## Scale Bar Mount

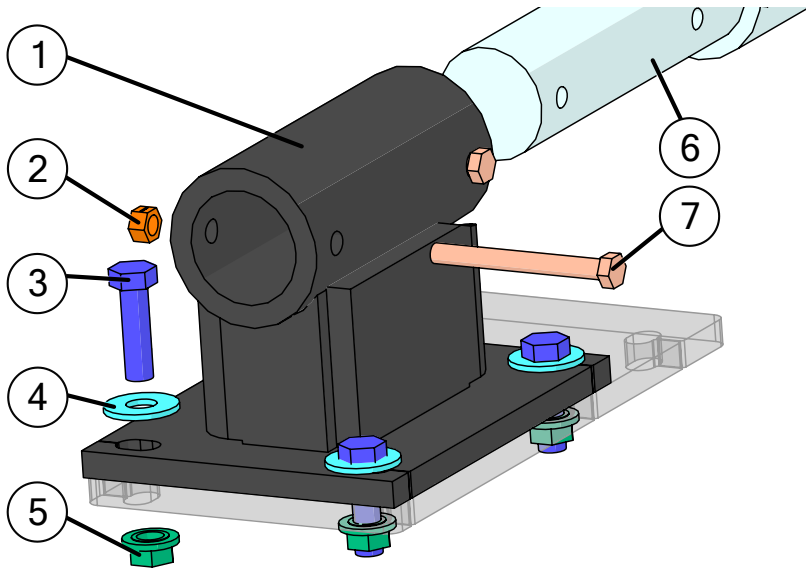

	Description	Part No.
1	Seed Tender Scale Mount Weldment (SMST4W)	JM0009966
2	3/8"-16 Gr2 Z Centerlock Hex Nut	JM0001512
3	1/2"-13 x 1-3/4" Gr5 Z Hex Bolt	JM0002101
4	1/2" ID, 1-3/8" OD Z Flat Washer	JM0003082
5	1/2"-13 Gr5 Z SF Hex Nut	JM0002153
6	Avery Weigh-Tronix 2-1/8" Weigh Bar (WB218)	JM0002797
6	Intercomp 2-1/8" Weigh Bar	JM0041719
7	3/8"-16 x 3-1/2" Gr5 Z Hex Bolt	JM0001986

## Non-Scale Bar Mount

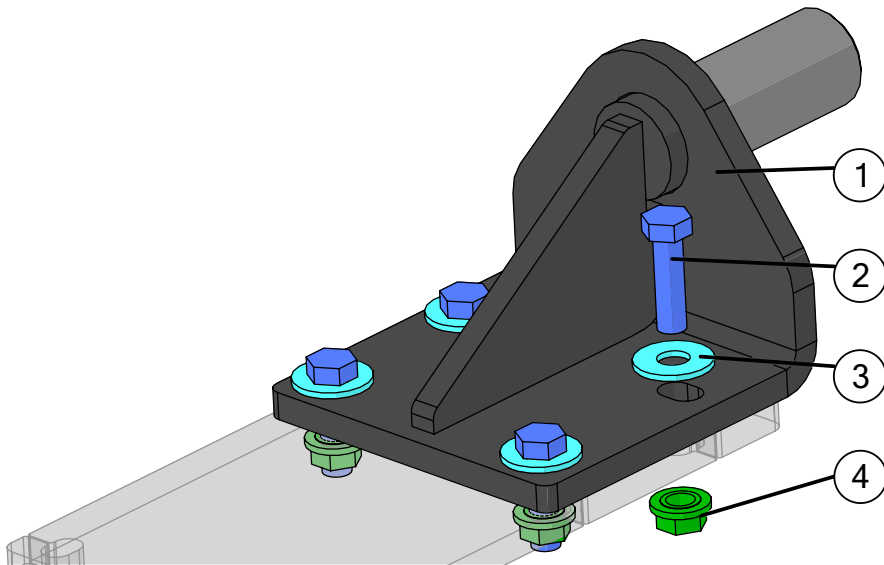

	Description	Part No.
1	Seed Tender Non-Scale Weldment	JM0002514
2	1/2"-13 x 1-3/4" Gr5 Z Hex Bolt	JM0002101
3	1/2" ID, 1-3/8" OD Z Flat Washer	JM0003082
4	1/2"-13 Gr5 Z SF Hex Nut	JM0002153

# Chassis

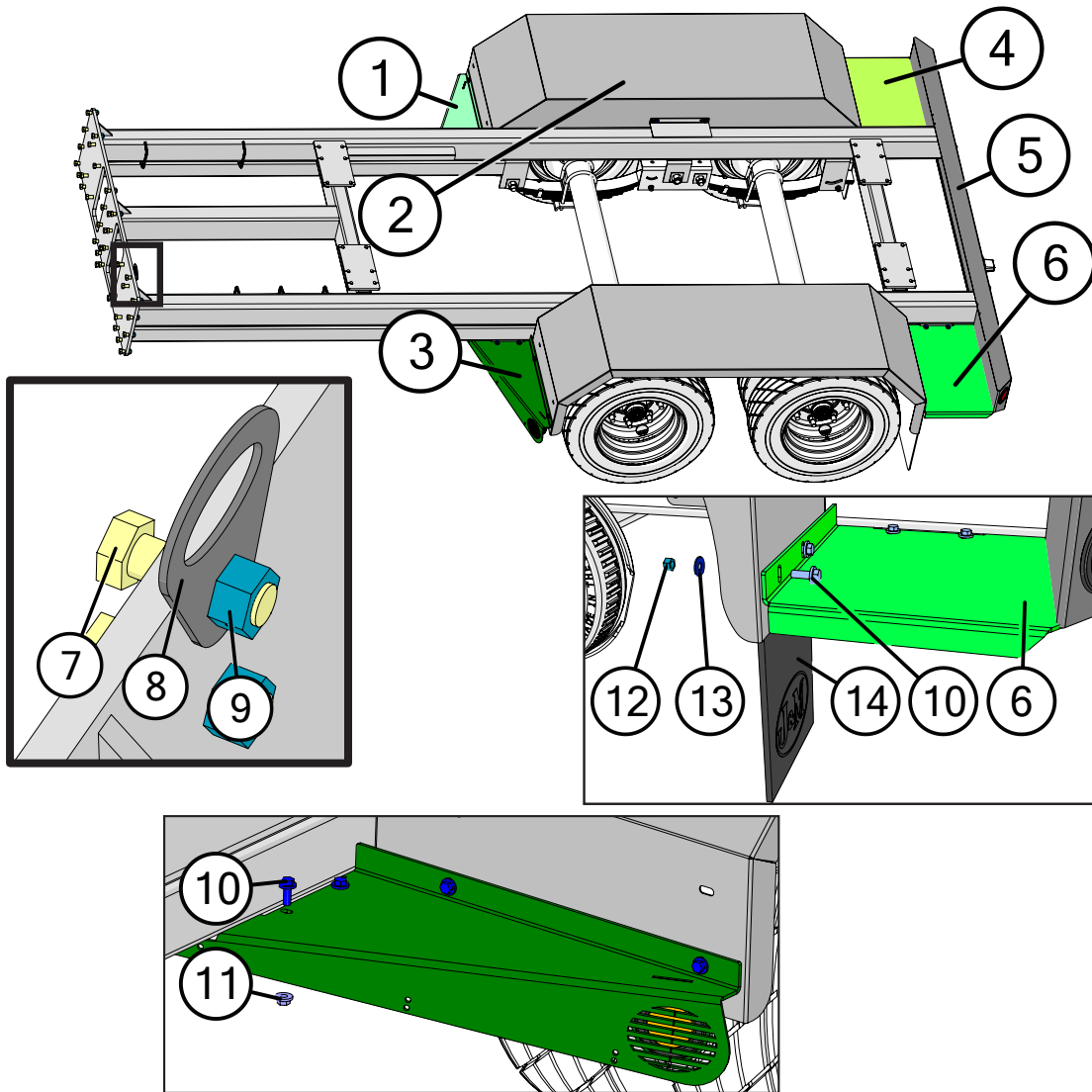

	Description	Part No.
1	Passenger Side Front Fender Bracket, 535 Seed Tender	JM0085646
2	535 Fender Weldment	JM0027229
3	Driver Side Front Fender Bracket, 535 Seed Tender	JM0085647
4	Rear Fender Step, DS	JM0026997
5	535 Rear Bumper Weldment	JM0026933
6	Rear Fender Step, PS	JM0026846
7	5/8"-11 x 2" Gr8 Z Hex Bolt	JM0001771
8	Wiring Hanger Tab (Seed Tender Chassis)	JM0002346
9	5/8"-11 Gr2 Z Centerlock Hex Nut	JM0002146
10	3/8"-16 x 1" Gr5 Z SF Hex Bolt	JM0002092
11	3/8"-16 Gr5 Z SF Hex Nut	JM0002152
12	3/8"-16 Gr2 Z Centerlock Hex Nut	JM0001512
13	3/8" USS Flat Washer	JM0003061
14	J&M Mud Flap	JM0001910

# 16k Axle Dexter

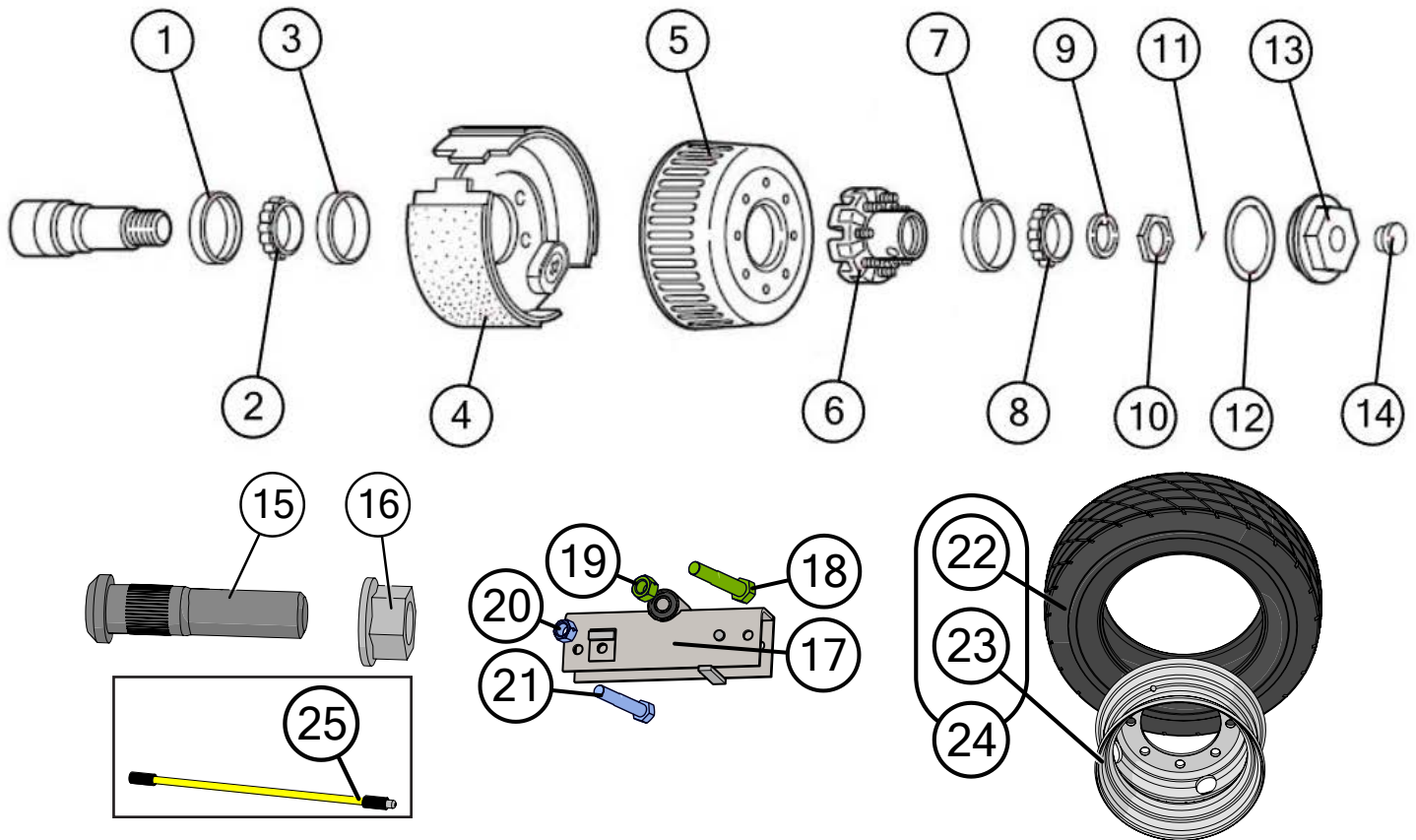

	Description	Part. No.
1	16k Oil Seal (010-056-00)	JM0042017
2	16K Large Bearing (031-097-02)(39250)	JM0042014
3	16k Large Race (031-097-01)(39520)	JM0042013
4	16k Brake Assembly LH	JM0042047
5	16k Brake Assembly RH	JM0042049
6	16k Drum (009-131-01)	JM0042046
7	16k Hub 10 on 8.75	JM0042045
8	16k Small Race (031-096-01)	JM0042015
9	16k Small Bearing (031-096-02)	JM0042016
9	16k Spindle Washer 3" OD (005-224-00)	JM0042050
10	16k Spindle Nut (006-239-00)	JM0042055
11	16k Cotter Pin (019-035-00)	JM0042054
12	16k O-Ring (Oil Cap)	JM0042051
13	16k Oil Cap Kit (021-219-00, 010-258-00, 085-017-00)	JM0042053
14	16k Plug (Oil Cap)	JM0042052
15	16k Stud 3/4" x 4"	JM0042043
16	3/4" Flange Nut with Washer for 16K	JM0042044
17	Equalizer Assembly Short LH w/Rubber Bushing(15.75")(Tandem on 38"-535)	JM0026794
17	R/H Equalizer	JM0026795
18	1"-8 x 6-1/2" Gr5 Z Hex Bolt	JM0014192
19	1"-8 Gr2 Z Centerlock Hex Nut	JM0002149
20	3/4"-10 Gr2 Z Centerlock Hex Nut	JM0002147
21	3/4"-10 x 4-3/4" Gr5 Z Hex Bolt	JM0041868
22	Tire 215/75R17.5	JM0081717
23	Rim Dual 17.5x6.75 VdAcWhite 8/275 SH	JM0081713
24	535 Wheel & Tire 215/75R17.5, 16PR, I-109 Dual 17.5x7.00	JM0081716
25	Valve Stem Extension 13-1/2" (535 Duals)	JM0030368

# Gooseneck

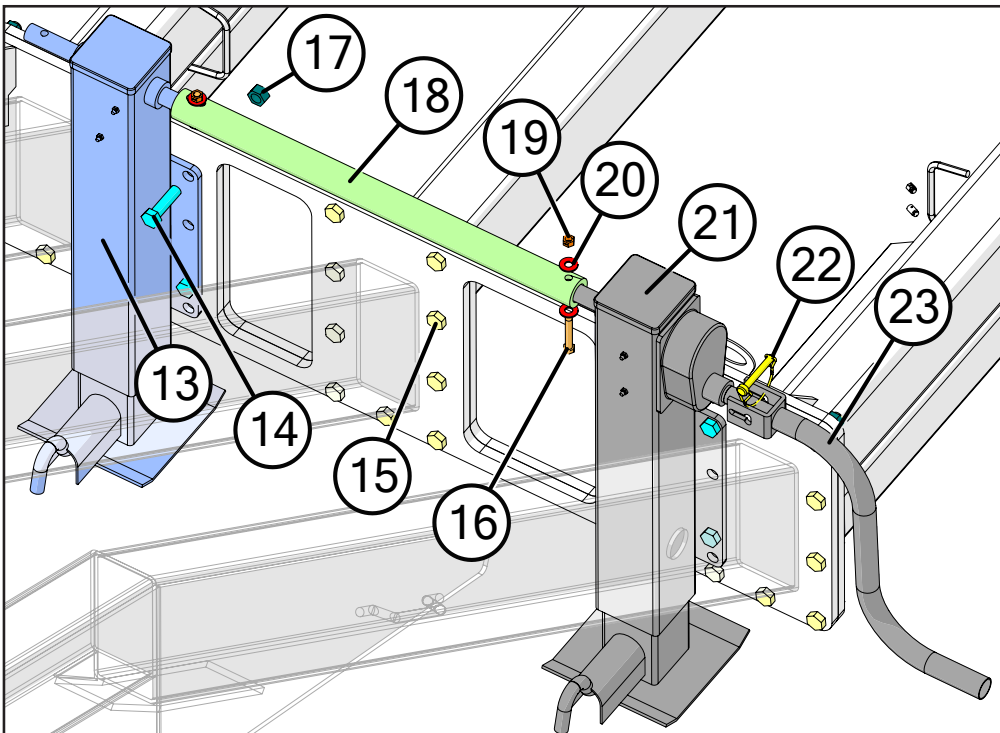
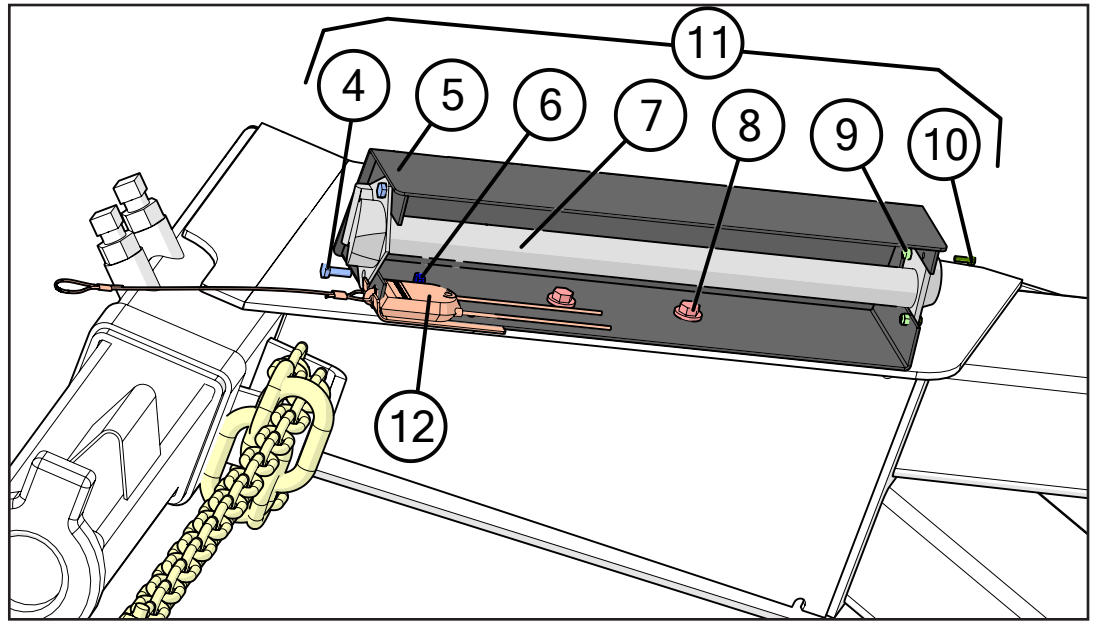
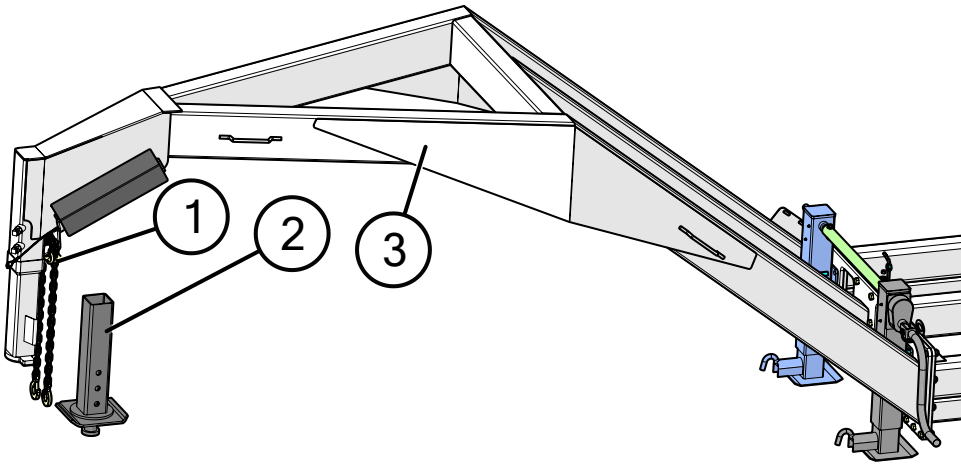



# Gooseneck

	Description	Part No.
1	5/16" P7 43" O. Safety Chain (500ST) (TF5S)	JM0016075
2	5th Wheel Receiver Tube 30,000# CAP	JM0016068
3	535 Gooseneck Weldment	JM0041154
4	1/4"-20 x 3/4" Gr5 Z Hex Bolt	JM0001507
5	Semi Adapter Weldment (ST)	JM0015567
6	1/4"-20 Gr2 Z Centerlock Hex Nut	JM0001505
7	5th Wheel Harness Adapter(ST)	JM0016178
8	3/8"-16 x 1" Gr5 Z SF Hex Bolt	JM0002092
9	#8-32 Z Nylon Locking Hex Nut	JM0012334
10	#8-32 x 1/2" Slotted Hex Washer Head Machine Screw	JM0012333
11	5Th Wheel Flat To 7 Way Round Adapter Assembly(ST)	JM0016179
12	Breakaway Switch with Cable (BAS-1)	JM0001843
13	535 Jack Weldment	JM0030056
14	5/8"-11 x 3" Gr5 Z Hex Bolt	JM0002105
15	5/8"-11 x 2" Gr8 Z Hex Bolt	JM0001771
16	3/8"-16 x 2-1/4" Gr5 Z Hex Bolt (160026)	JM0001660
17	5/8"-11 Gr2 Z Centerlock Hex Nut	JM0002146
18	Companion Jack Coupler 535 (1-3/4" x 25-1/2")	JM0030060
19	3/8"-16 Gr2 Z Centerlock Hex Nut	JM0001512
20	3/8" USS Flat Washer	JM0003061
21	Gooseneck Manual Jack with Custom Mounting Plate (10,000#)	JM0007078
22	3/8" x 2-1/2" Wire Lock Pin (38212WLP)	JM0014929
23	Gooseneck Jack Handle	JM0007061

# Hydraulic Jack

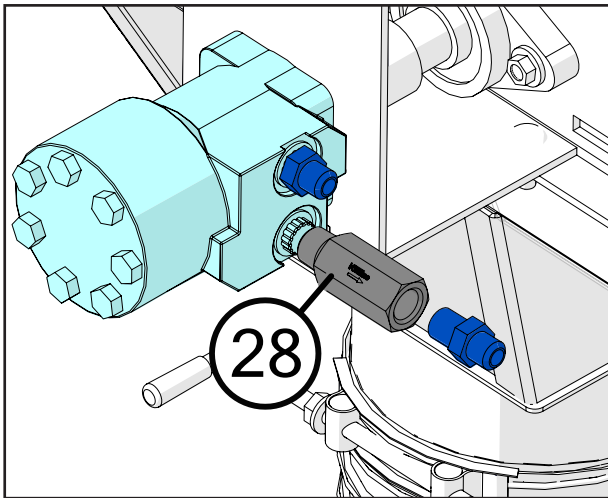
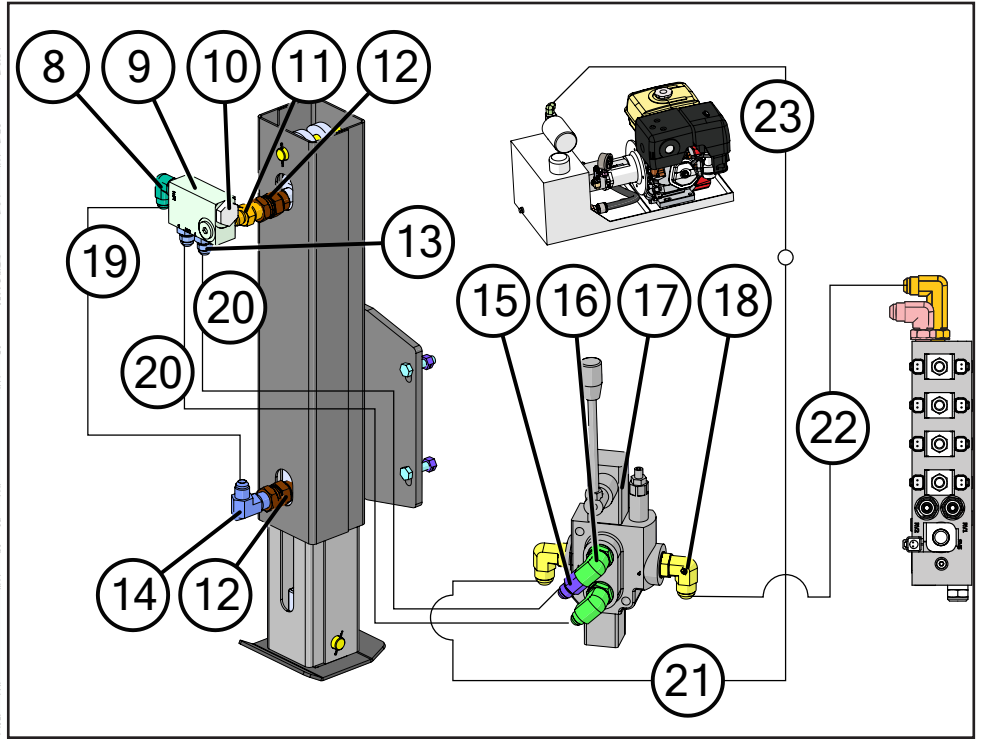
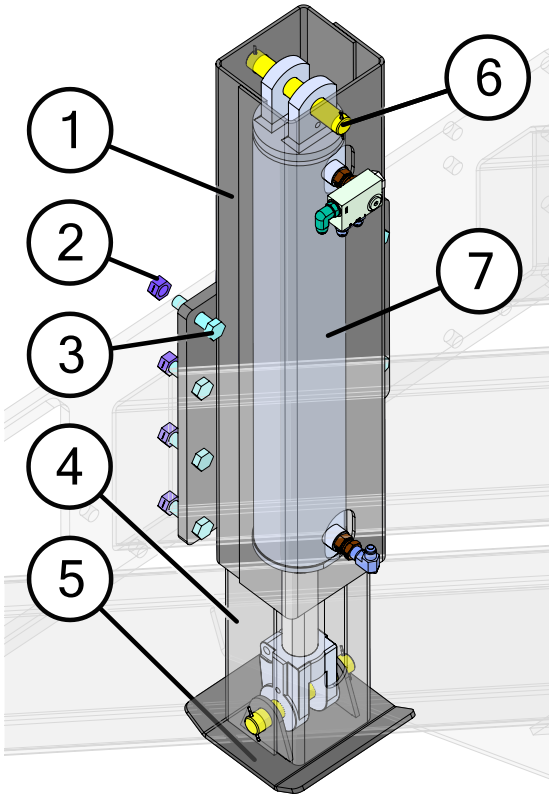

When installing a hydraulic jack you will need to add this valve to the end of the conveyor as shown in the image above.

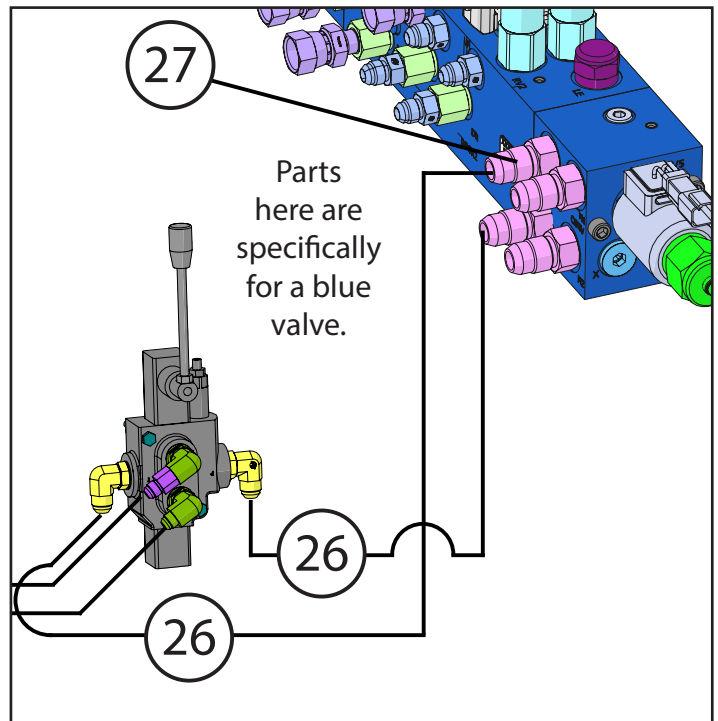

# Hydraulic Jack

	Description	Part No.
1	4 x 24 Hydraulic Jack Top Weldment	JM0077397
2	5/8"-11 Gr2 Z Centerlock Hex Nut	JM0002146
3	5/8"-11 x 2-1/2" Gr8 YZ Hex Bolt	JM0061679
4	4x24 Hydraulic Jack Lower Shell Weldment	JM0077410
5	Foot Pad Weldment (Hydraulic Jack)	JM0074390
6	1" x 6" Pin	JM0031495
7	4" Bore, 24" Stroke Welded Hydraulic Cylinder - Heavier Clevises	JM0030730
7	Seal Kit for 4" x 24" Hydraulic Cylinder (JD-609)	JM0039242
8	3/8" Male JIC x 3/8" Male ORB; 90 Degree Elbow	JM0026121
9	Serviceable Pilot Check Valve	JM0061684
10	Check Valve Cartridge (CPB25)	JM0074412
11	3/8" Male NPT x 3/8" Male ORB; Straight	JM0061726
12	1/2" Male ORB x 3/8" Female NPSM Swivel; Straight	JM0010298
13	3/8" Male JIC x 3/8" Male ORB; Straight	JM0043614
14	3/8" Male NPT x 3/8" Male JIC; 90 Degree Elbow	JM0061728
15	3/8" Male JIC x 3/8" Female JIC with .047 Orifice	JM0054918
16	3/8" Male JIC x 1/2" Male ORB; 90 Degree Elbow	JM0037159
17	Hydraulic Jack Hand Valve with Pressure Relief (Youli MB2)	JM0031858
18	#8 Male JIC x #8 Male ORB - Elbow	JM0073266
19	3/8" x 25" Hydraulic Hose 25inch6M3K-6G-6FJX-6G-6FJX	JM0049162
20	3/8" x 68" Hydraulic Hose 68inch6M3K-6G-6FJX-6G-6FJX	JM0073253
21	1/2" x 34" Hydraulic Hose 34inch8M3K-8G-8MJX-8G-8FJX	JM0073263
22	1/2" x 68" Hydraulic Hose 68inch8M3K-8G-8FJX-8G-8FJX	JM0073262
23	1/2" x 34" Hydraulic Hose 34inch8M3k-8G-8FJX-8G-8FJX	JM0025347
24	1/2" x 43" Crimped Hydraulic Hose - 43inch8CR2-8G-8FJX-8G-8FJX	JM0083304
25	1/2" Male JIC x 1/2" Male O-ring; Straight	JM0010293
26	Vonberg Ball Style Check Valve - 10101-504	JM0085658

## Hydraulic Motor Assembly 2024 - Current

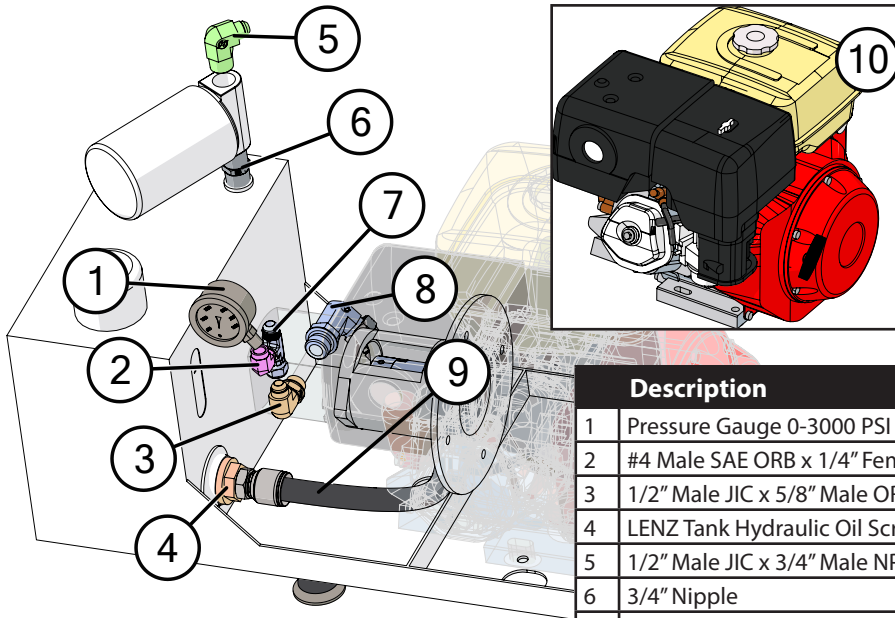

	Description	Part No.
1	Pressure Gauge 0-3000 PSI (P562713)	JM0037742
2	#4 Male SAE ORB x 1/4" Female Pipe 90 Deg Elbow	JM0085124
3	1/2" Male JIC x 5/8" Male ORB; 90 Degree Elbow	JM0039215
4	LENZ Tank Hydraulic Oil Screen (LTMA-10-100)	JM0084748
5	1/2" Male JIC x 3/4" Male NPT; 90 Degree Elbow	JM0033775
6	3/4" Nipple	JM0010137
7	#8 Female JIC X #8 Male JIC X #4 Gauge Port - Tee	JM0085121
8	#12 Male NPT x #12 Female JIC Swivel - Extra Long Elbow	JM0084903
9	3/4" x 18" Crimped Hydraulic Hose - 18inch12CR2-12G-12MORB-12G-12FJX	JM0084751
10	Honda GX390 Engine	JM0001749

## Hydraulic Motor Assembly 2024 - Older

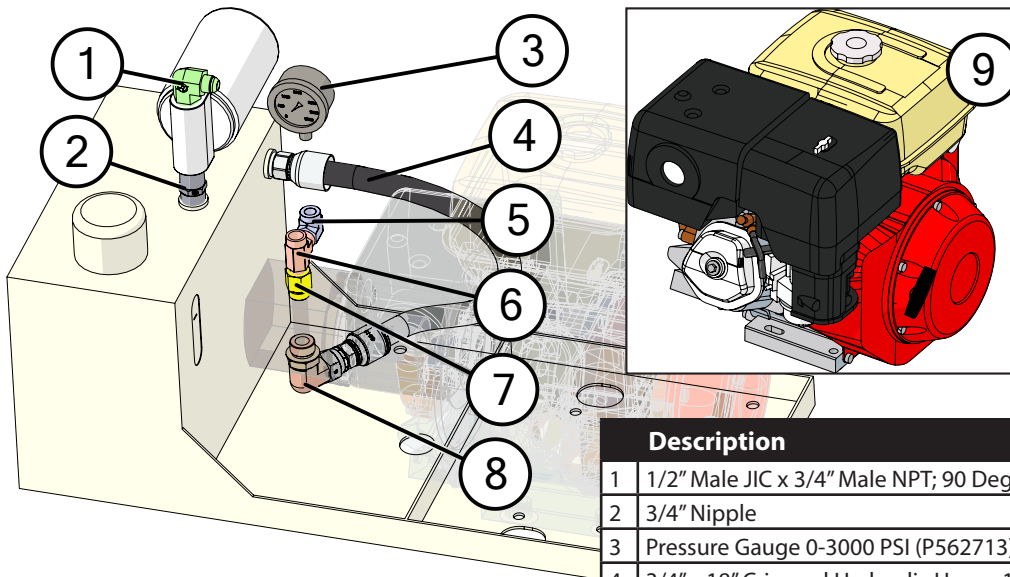

	Description	Part No.
1	1/2" Male JIC x 3/4" Male NPT; 90 Degree Elbow	JM0033775
2	3/4" Nipple	JM0010137
3	Pressure Gauge 0-3000 PSI (P562713)	JM0037742
4	3/4" x 18" Crimped Hydraulic Hose - 18inch12CR2-12G-12MP-12G-12FJX	JM0086698
5	#6 Male NPT x #4 Female NPT - Elbow	JM0037487
6	3/8" Male NPT x 3/8" Female NPT x 3/8" Female NPT; Street T	JM0018266
7	#10 Male ORB x #6 Female NPT - Straight	JM0037488
8	#12 Male JIC x #12 ORB Male - Elbow (6801-12-12)	JM0037489
9	Honda GX390 Engine	JM0001749

## Spare Tire Mount

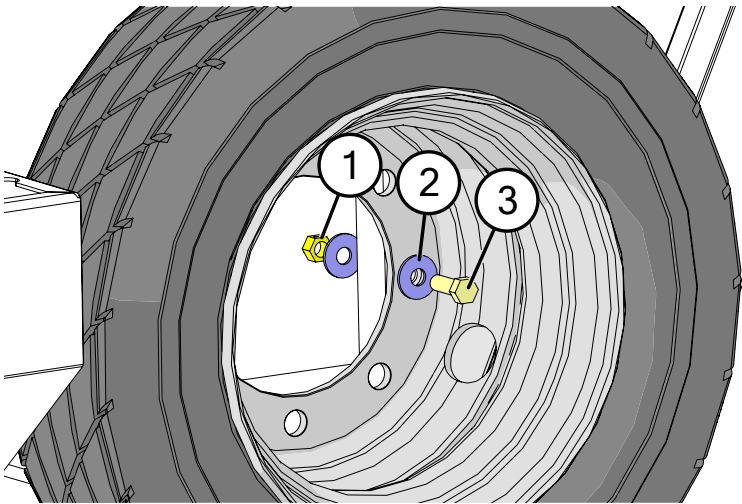

	Description	Part No.
1	9/16" USS Flat Washer	JM0050968
2	9/16"-18 Conical Lugnut (4WS) (ST)	JM0008525
3	9/16"-18 x 7-1/2" Full Thread Stud	JM0010068

## Spout Options

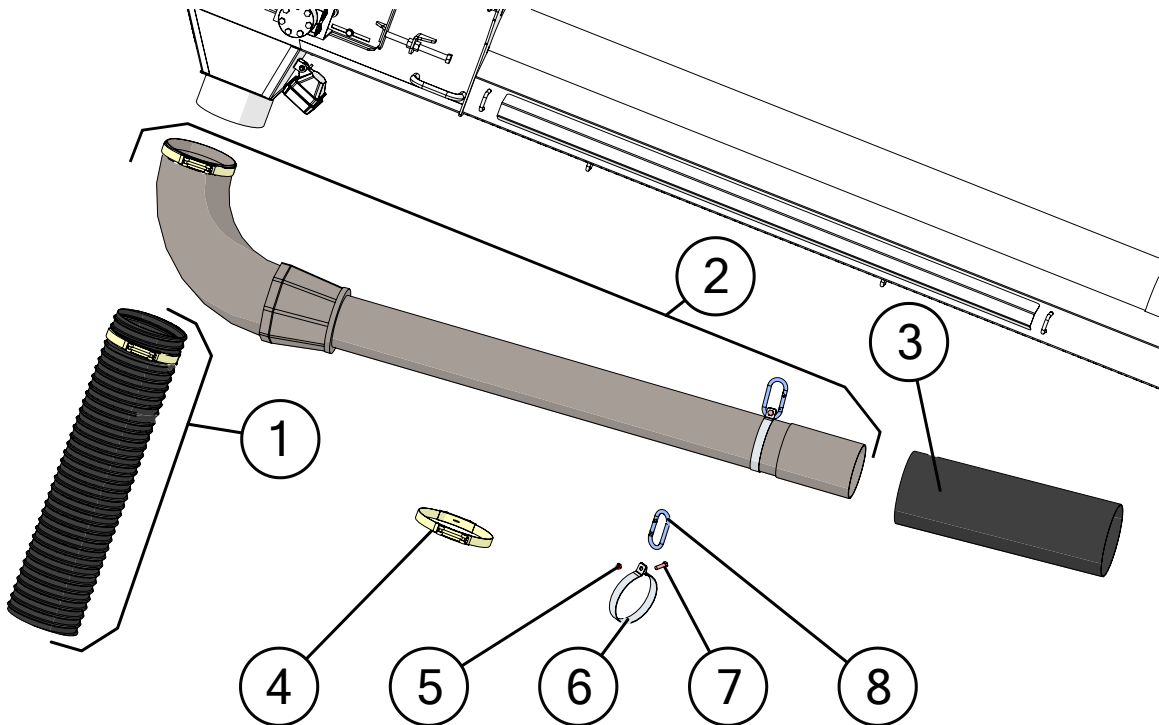

	Description	Part No.
1	36" Flex Hose for 10" Conveyor (535) with clamp	JM0087049
2	10" dia x 12' Long 2 Stage Tele Spout with Handle, Clamp and Carabiner	JM0081727
3	10" Telespout Sock	JM0017580
4	10" Hose Clamp	JM0042060
5	3/8"-16 Gr2 Z Centerlock Hex Nut	JM0001512
6	Carabiner Band for 10" Telescoping Spout	JM0081730
7	3/8"-16 x 1-1/4" Gr5 Z Hex Bolt	JM0016675
8	Oval .438 dia x 1-3/8" x 3-7/8" Z Carabiner	JM0010511

# Swing Arm

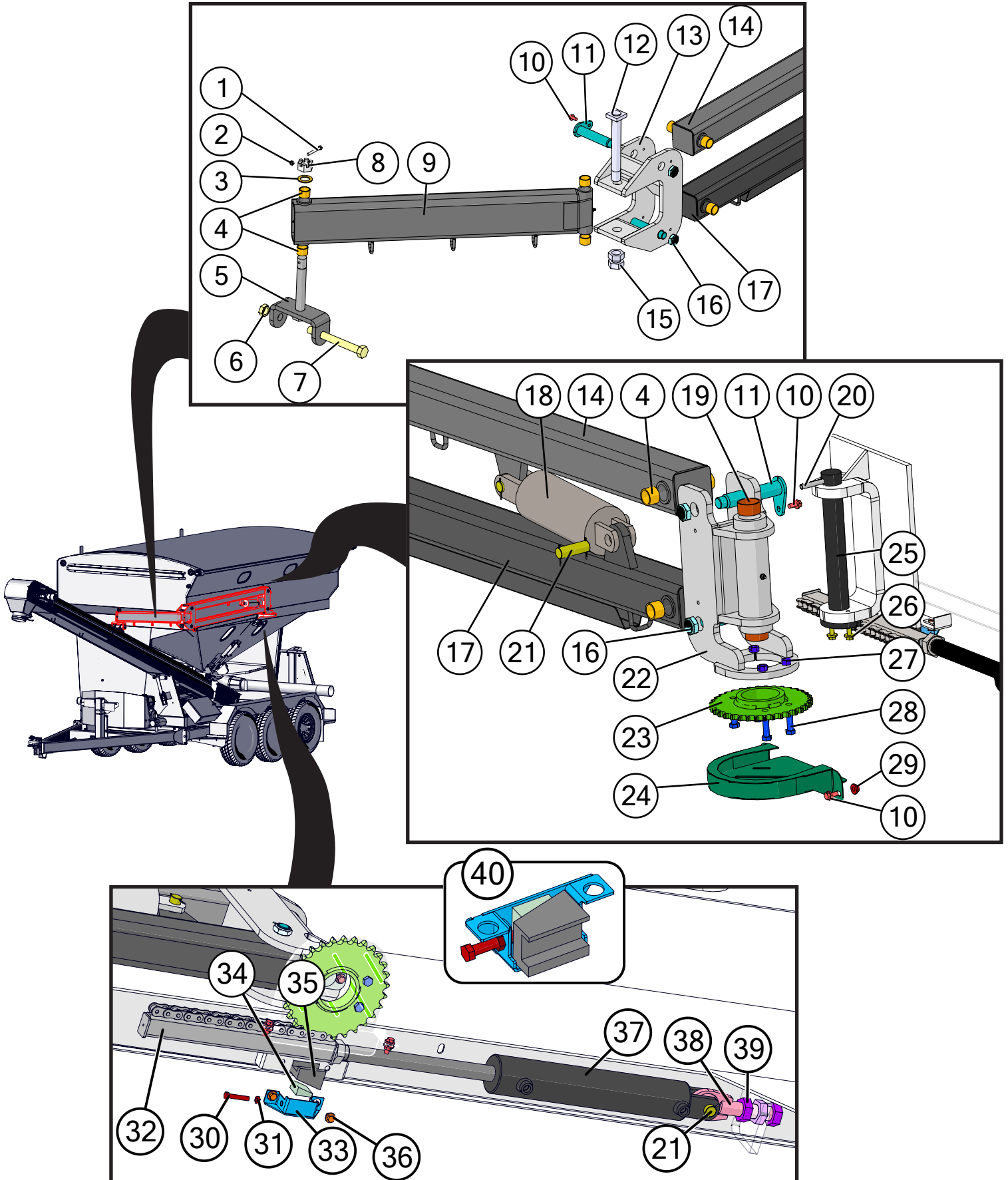

# Swing Arm

	Description	Part No.
1	5/16"-18 x 2-1/2" Gr5 Z Hex Bolt	JM0028310
2	5/16"-18 Gr2 Z Centerlock Hex Nut	JM0002143
3	1-1/4" ID x 2" OD Bronze Washer	JM0040435
4	1-1/4" x 1-1/2" x 2" LG Sleeve Composite Bearing	JM0040288
5	Upper Boom Pivot Weldment	JM0001605
6	1"-8 Gr2 Z Hex Jam Nut	JM0001705
7	1"-8 x 9" Gr8 Z Hex Bolt	JM0001708
8	1-1/4"-12 Gr2 Castle Hex Nut	JM0010113
9	Swivel Arm Weldment	JM0040253
10	3/8"-16 x 3/4" Gr5 Z SF Hex Bolt	JM0001750
11	1-1/4" x 6-3/4" Pin w/ Keeper Weldment	JM0040322
12	Horizontal Axis Boom Pivot Pin Weldment (9-5/8" x 1-1/4")	JM0002456
13	Swing Arm "C" Weldment	JM0040283
14	Parallel Linkage Arm - 4" Square - 535	JM0041094
15	1-1/4"-7 Gr2 Z Hex Nut	JM0001700
16	1"-14 Gr5 Z Nylon Locking Hex Jam Nut	JM0040430
17	Bottom Parallel Linkage Weldment - 535	JM0041092
18	4" x 6" Welded Cylinder	JM0040425
19	1-3/4" ID Bronze Bushing (2" OD x 1" Length) (EB-134)	JM0002244
20	7/16" x 2-3/4" Z Roll Pin	JM0009895
21	1" x 3" Clevis Pin with Cotter Pins	JM0019407
22	Parallel Linkage Spool Assembly (LC Series)	JM0040192
23	Conveyor Swing Sprocket Weldment, 80 Chain (LC 535)	JM0080010
24	Guard - Conveyor Swing Sprocket	JM0040567
25	Pin Conveyor Swing (1-3/4" x 14")	JM0040354
26	3/8"-16 x 1" Gr5 Z SF Hex Bolt	JM0002092
27	1/2"-13 Gr2 Z Centerlock Hex Nut	JM0001511
28	1/2"-13 x 1-3/4" Gr5 Z Hex Bolt	JM0002101
29	3/8"-16 Gr5 Z SF Hex Nut	JM0002152
30	3/8"-16 x 2" Gr5 Fully Threaded Z Hex Bolt	JM0054831
31	3/8"-16 Z Gr5 Hex Jam Nut - Bulk Head Fitting	JM0031242
32	LC 535 Chain Track for Swing Arm, 80 Chain	JM0080012
33	Adjustable Scrubber Holder Weldment for Swing Arm (LC 535)	JM0074664
34	Wedge For Adjustable Scrubber (LC Series)	JM0049196
35	Adjustable Scrubber Block (LC 535)	JM0079119
36	3/8"-16 x 1/2" Gr5 Z SF Hex Bolt	JM0040150
37	3" x 14" Welded Cylinder (No Clevis)	JM0041255
38	Adjustable Cylinder Mount Weldment (LC Series)	JM0040907
39	1-1/4"-12 Gr5 Z Hex Jam Nut	JM0002158
40	535 Scrubber Block Assembly	JM0080016

\*Starting in 2021 we used the 80 chain parts instead of 60 chain. If your model is older and you want to upgrade you need all three parts JM0080010, JM0080012, and JM0079119.

# Conveyor

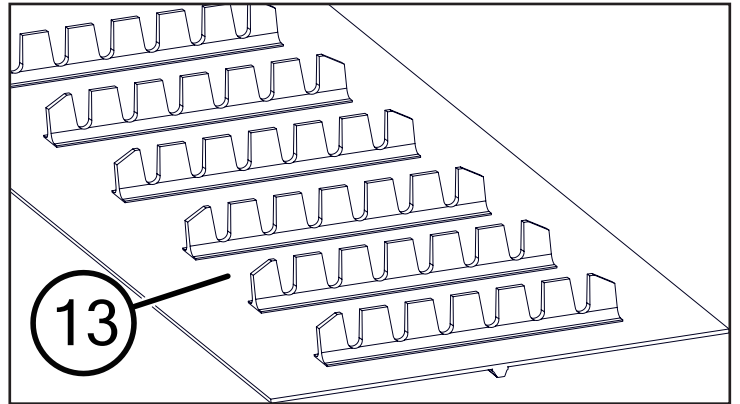
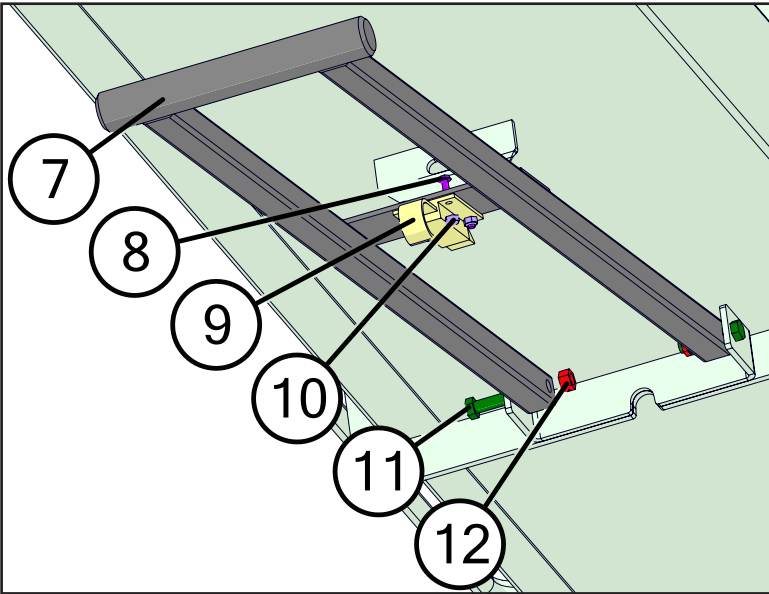
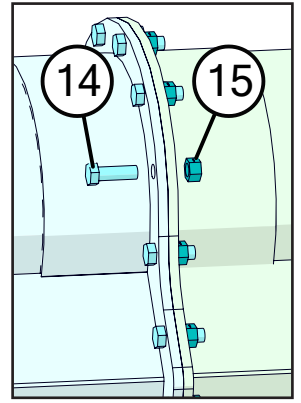
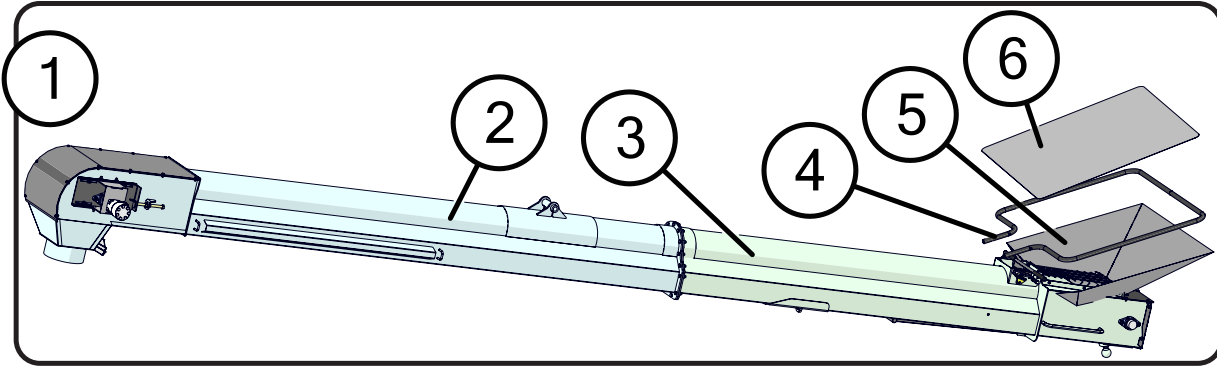

Description	Part No.
1 10" Tube Conveyor (V-Guide Belt)(535)(Complete)	JM0040697
2 10" Tube Conveyor Top Weldment - 535	JM0040699
3 10" Tube Conveyor Bottom Weldment	JM0040698
4 535 Hopper Hoop Weldment	JM0041871
5 Seed Tender Hopper Tarp 535	JM0041927
6 Speed Tender Hopper Cover (535LC)	JM0041930
7 Conveyor Support Stand	JM0002212
8 #10-24 x .563 Slotted Hex Washer Head Machine Screw	JM0016669
9 Leg Spring Plunger	JM0002789
10 #10-24 Z Nylon Locking Hex Nut	JM0016030
11 3/8"-16 x 1-3/4" Gr5 Z Hex Bolt	JM0002097
12 3/8"-16 Gr2 Z Centerlock Hex Nut	JM0001512
13 15-1/2" x 587" V-Guide Conveyor Belt (Artic)(535)	JM0047068
14 1/2"-13 x 1-1/2" Gr8 Z Hex Bolt	JM0038354
15 1/2"-13 Gr2 Z Centerlock Hex Nut	JM0038357



# Conveyor Discharge End

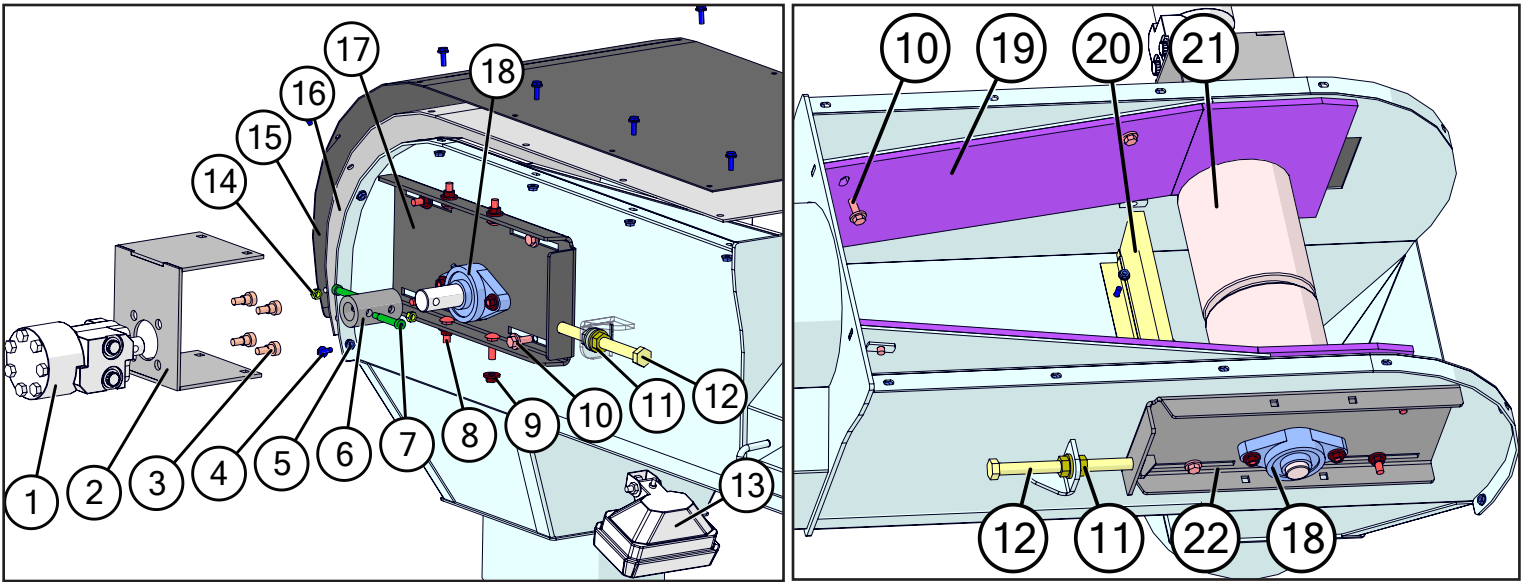

	Description	Part No.
1	WR Series Hydraulic Motor with Keyway and Pinhole (15100F30N6AAAAA)	JM0010469
1	Seal Kit for 15100F30N6AAAAA WR Series Hydraulic Motor	JM0042773
2	Hydraulic Motor Mount (DMST375W)	JM0002225
3	1/2" Shoulder Dia x 3/8" Shoulder Length x 3/8"-16 Socket Shoulder Bolt	JM0009998
4	1/4"-20 x 3/4" Gr5 Z SF Hex Bolt	JM0001642
5	1/4"-20 Gr5 Z SF Hex Nut	JM0001630
6	Motor to Roller Connector	JM0022054
7	3/8" Shoulder Dia x 1-3/4" Shoulder Length x 5/16"-18 Socket Shoulder Bolt	JM0033449
8	3/8"-16 x 1-1/4" Gr5 Z Carriage Bolt	JM0001639
9	3/8"-16 Gr5 Z SF Hex Nut	JM0002152
10	3/8"-16 x 1" Gr5 Z SF Hex Bolt	JM0002092
11	5/8"-11 Gr5 Z SF Hex Nut	JM0002151
12	5/8"-11 x 7-1/2" Gr5 Z Hex Bolt	JM0001631
13	LED Field Light with Weather Pack Connectors (SpeedTender, NitroGro)	JM0050942
14	5/16"-18 Gr2 Z Centerlock Hex Nut	JM0002143
15	Belt Conveyor Discharge Cover 535	JM0025379
16	10" Conveyor Head Pan Rubber	JM0025374
17	Drive side tension bracket weldment (ST375DBTW)	JM0002235
18	1-1/4" Flange Bearing (2 bolt) (ST) (114BST375)	JM0001811
19	Top Skirting (535) (29-7/8" x 10-3/4")	JM0030506
20	16" V-Guide Brush Assembly for 10" Conveyor	JM0030852
21	Drive Roller For V Guide Belt (535)	JM0025414
22	Motor Side Tension Bracket Weldment (ST375BTW)	JM0002234

# Conveyor Idler End

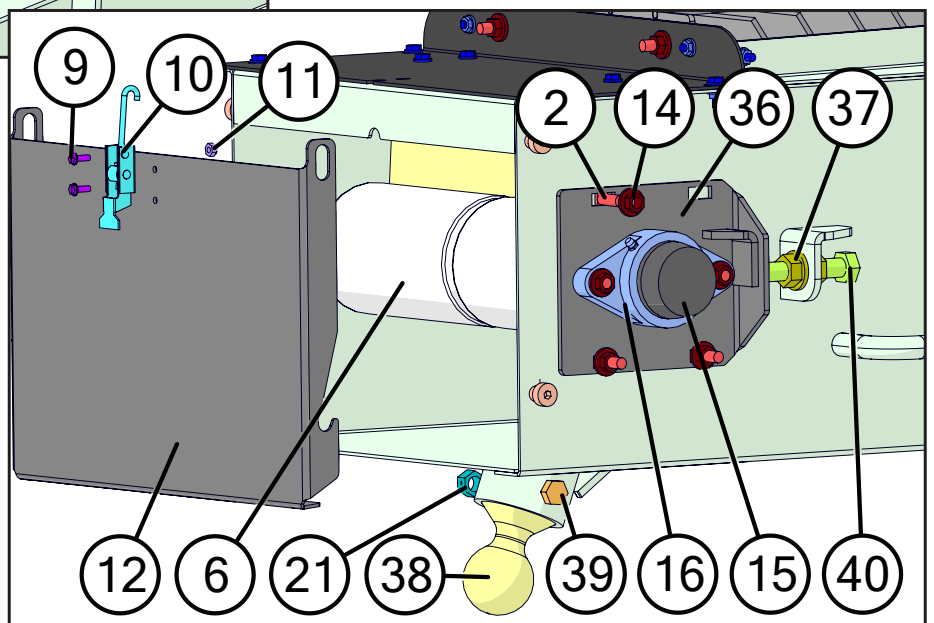
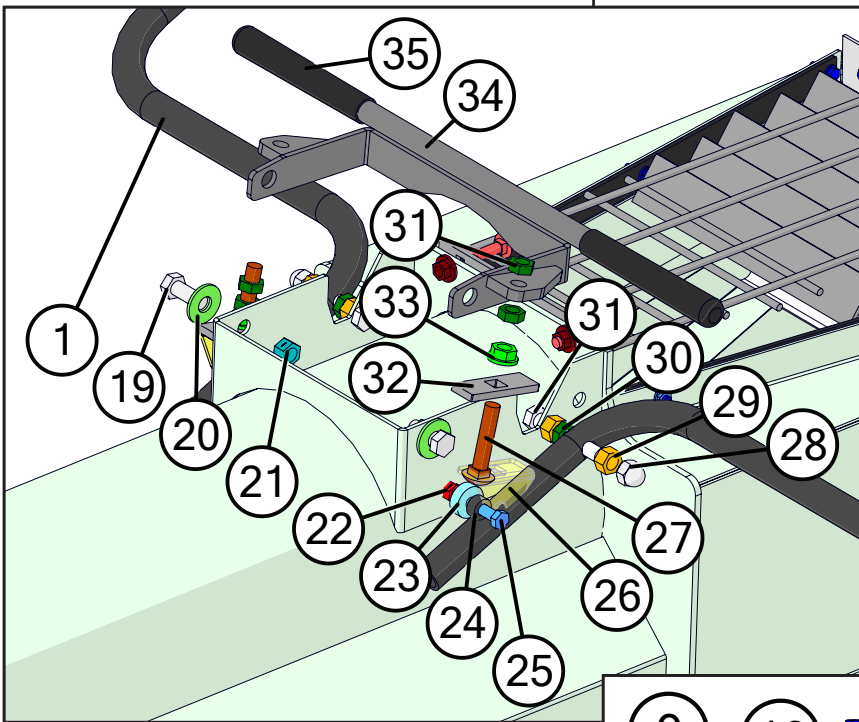
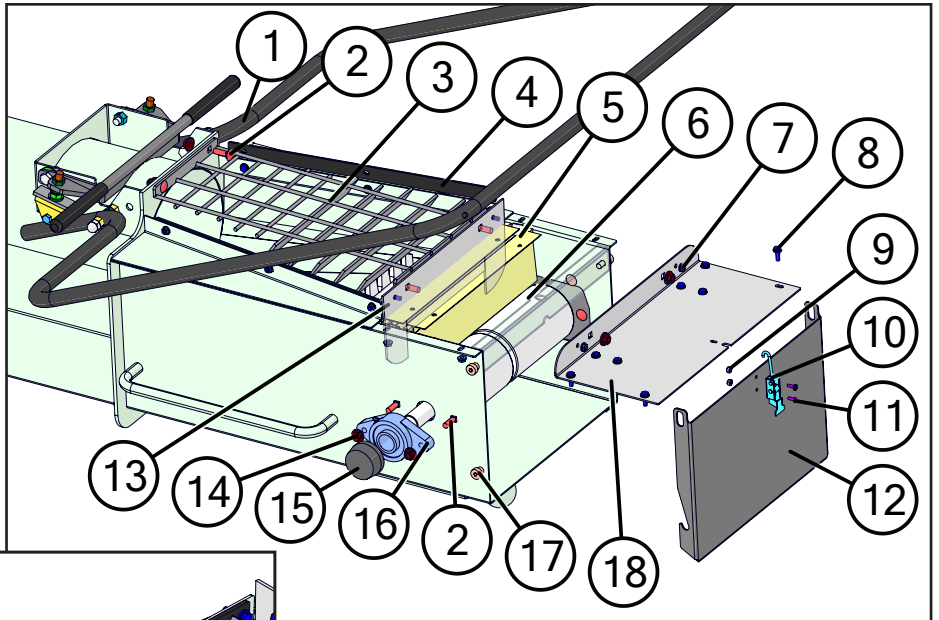

# Conveyor Idler End

	Description	Part No.
1	535 Hopper Hoop Weldment	JM0041871
2	3/8"-16 x 1-1/4" Gr5 Z Carriage Bolt	JM0001639
3	500ST Conveyor Guard	JM0025667
4	Hopper Tarp Clamp Plate (535)	JM0025652
5	16" V-Guide Brush Assembly for 10" Conveyor	JM0030852
6	Tube Conveyor Roll, V-Guide, Idler (20-1/2" x 4-1/4" dia)(535)	JM0025430
7	1/4"-20 Gr5 Z SF Hex Nut	JM0001630
8	1/4"-20 x 3/4" Gr5 Z SF Hex Bolt	JM0001642
9	#10-24 Z Nylon Locking Hex Nut	JM0016030
10	Adjustable Draw Latch (A1-11-502-10)	JM0010512
11	#10-24 x .563 Slotted Hex Washer Head Machine Screw	JM0016669
12	Cleanout Door (LC535)	JM0025727
13	10" Tube Conveyor Bottom Skirting	JM0031810
14	3/8"-16 Gr5 Z SF Hex Nut	JM0002152
15	2 Bolt Flange Bearing Safety Cap (1-1/4" Diameter)	JM0015906
16	1-1/4" Flange Bearing (2 bolt) (ST) (114BST375)	JM0001811
17	1/2" Shoulder Dia x 3/8" Shoulder Length x 3/8"-16 Socket Shoulder Bolt	JM0009998
18	Conveyor Hopper Brush Mount (535)	JM0025616
19	1/2"-13 x 1-1/4" Gr5 Z Hex Bolt	JM0001513
20	1/2" ID, 1-3/8" OD Z Flat Washer	JM0003082
21	1/2"-13 Gr2 Z Centerlock Hex Nut	JM0001511
22	3/8"-16 Gr2 Z Centerlock Hex Nut	JM0001512
23	Stainless Steel Roller Bearing (3/8" ID, 1-1/8" OD)	JM0001828
24	3/4" OD, 13/32" ID x 3/8" Black Nylon Spacer	JM0021981
25	3/8"-16 x 1-1/4" Gr5 Z Hex Bolt	JM0016675
26	Hopper Handle Bearing Mount (w/ bearing and hardware)	JM0002220
27	1/2"-13 x 2-1/2" Gr5 Z Carriage Bolt	JM0014197
28	1/2"-13 Gr5 Z Acorn Hex Nut (160041)	JM0001772
29	1/2"-13 Gr2 Z Hex Nut	JM0002124
30	1/2"-13 Z Gr5 Hex Jam Nut	JM0002157
31	1/2"-13 x 3" Gr5 Z Hex Bolt	JM0016678
32	Slider Pad, Seed Tender Hopper Stop	JM0014182
33	1/2"-13 Gr5 Z SF Hex Nut	JM0002153
34	10" Tube Conveyor Hopper Lock Weldment	JM0025794
35	Rubber Handle Cap Black (6")	JM0016782
36	Idler Tension Bracket Weldment (ST375ITBW)	JM0002199
37	5/8"-11 Gr5 Z SF Hex Nut	JM0002151
38	2-1/2" Goose Ball - (Bolt-In)	JM0040884
39	1/2"-13 x 3-1/2" Gr5 Z Hex Bolt	JM0009914
40	5/8"-11 x 3-1/2" Gr5 Z Hex Bolt	JM0001650

# Shell

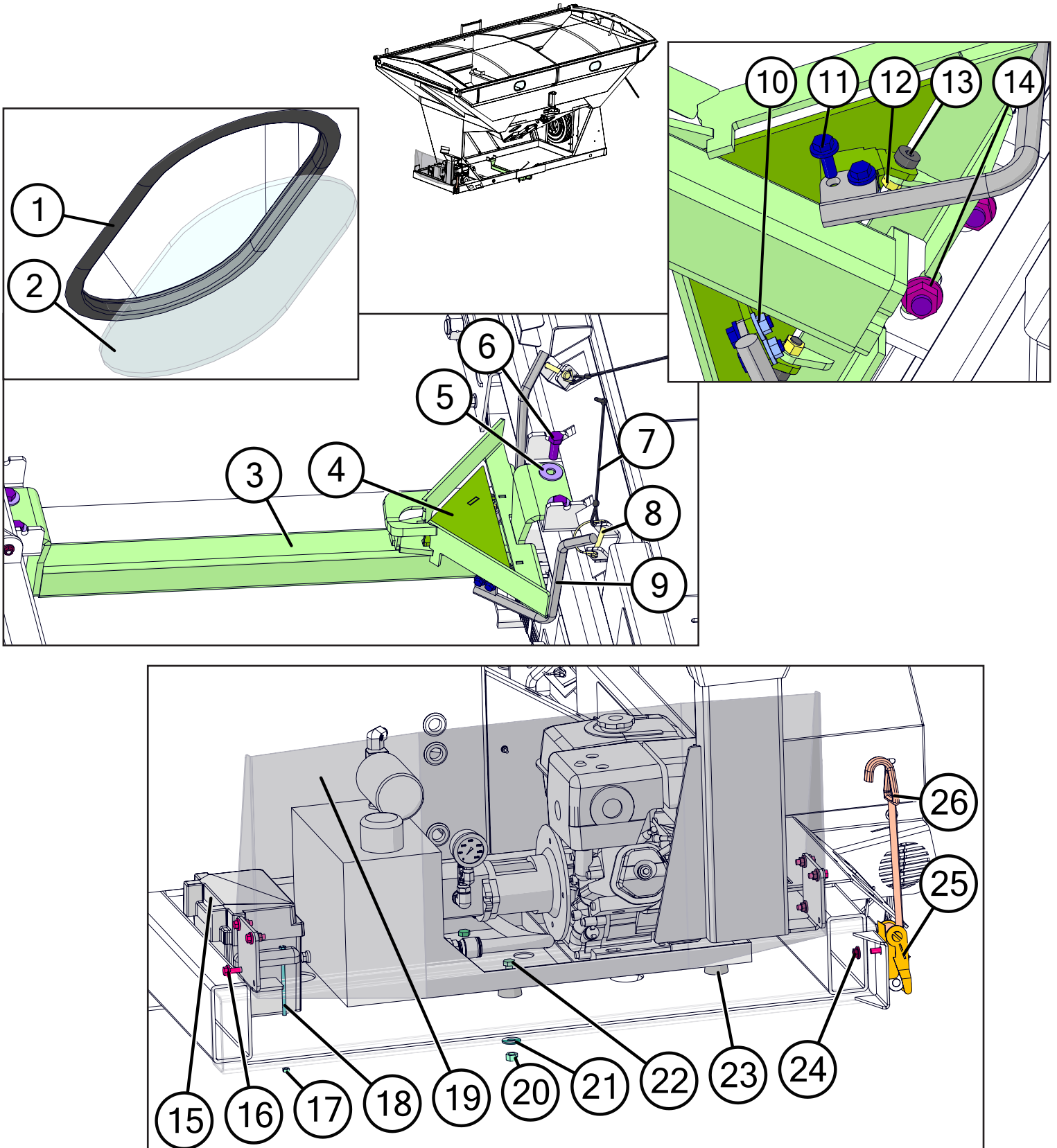

# Shell

	Description	Part No.
1	Window Seal 3/4" S' Strip	JM0000254
2	Standard Inspection Window	JM0000255
3	535 Ball Support Weldment	JM0041747
4	Ball Latch Flapper Weldment	JM0041464
5	5/8" USS Flat Washer	JM0003073
6	5/8"-11 x 1-3/4" Gr5 Z Hex Bolt	JM0016681
7	Plastic Lanyard with Plastic Plug	JM0041431
8	3/8" x 2-1/2" Wire Lock Pin (38212WLP)	JM0014929
9	500 ST Handle	JM0041269
10	3/8"-16 Gr5 Z SF Hex Nut	JM0002152
11	3/8"-16 x 1" Gr5 Z SF Hex Bolt	JM0002092
12	3/8"-16 x 1" Gr5 Z SF Hex Bolt	JM0002092
13	3/8"-16 Gr2 Z Centerlock Hex Nut	JM0001512
14	5/8"-11 Gr5 Z SF Hex Nut	JM0002151
15	Battery Box (SpeedTender)	JM0001846
16	3/8"-16 x 1" Gr5 Z SF Hex Bolt	JM0002092
17	1/4"-20 Gr2 Z Centerlock Hex Nut	JM0001505
18	1/4"-20 x 6" Gr5 Z Hex Bolt	JM0049441
19	Engine Cover (Seed Tender) (ECST375)	JM0000327
20	1/2"-13 Gr2 Z Centerlock Hex Nut	JM0001511
21	1/2" ID, 1-3/8" OD Z Flat Washer	JM0003082
22	1/2"-13 x 2" Gr5 Z Hex Bolt	JM0001593
23	Neoprene Vibration Damping Mount with 5/8" Diameter Hole	JM0001869
24	3/8"-16 Gr5 Z SF Hex Nut	JM0002152
25	2" Tie-Down Ratchet (10,000 lb) (RA-1)	JM0003084
26	2" Wide x 42" Long 10,000lb Webbing with Double J Hook	JM0010217

# Hydraulic Door

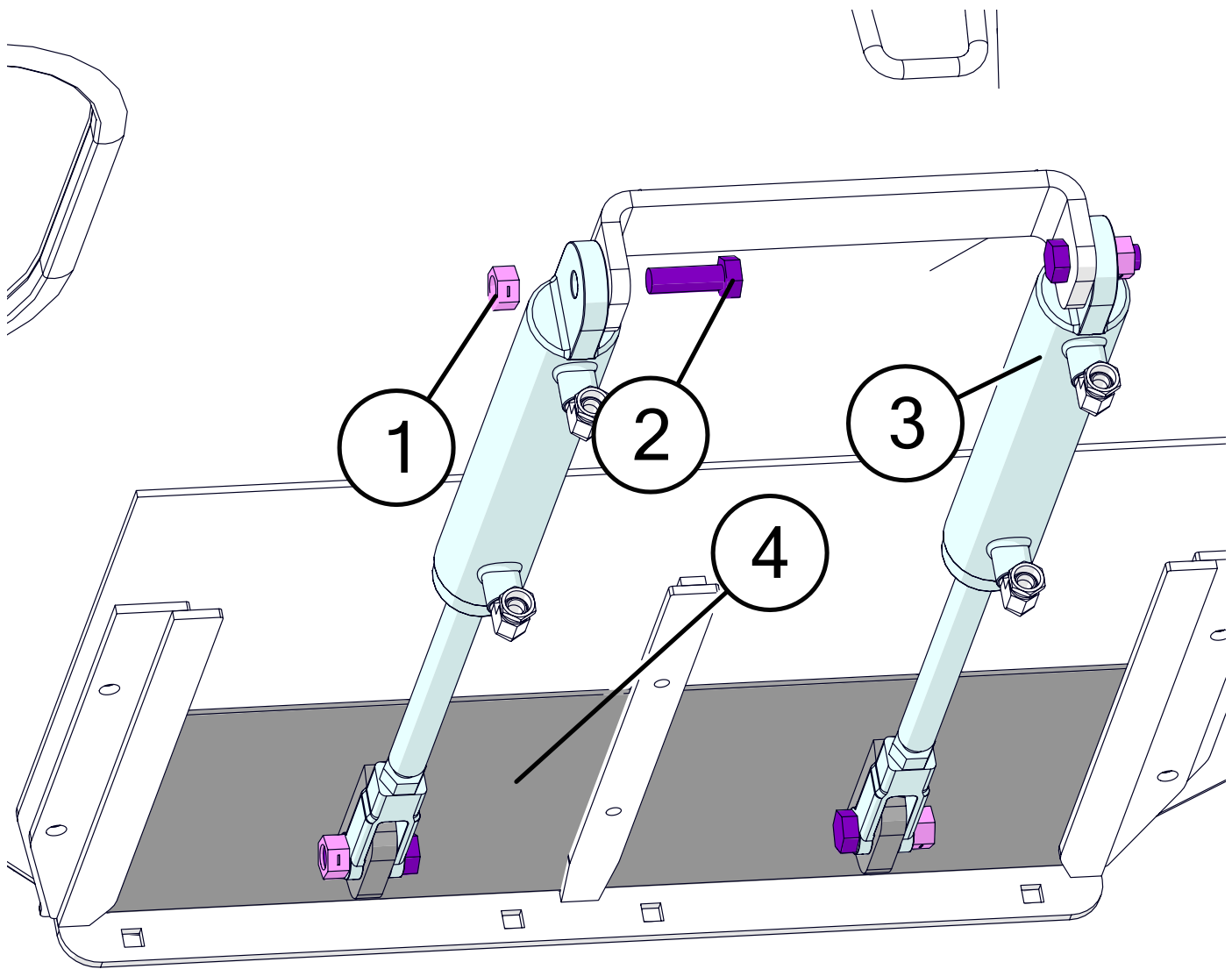

	Description	Part No.
1	1/2"-13 Gr2 Z Centerlock Hex Nut	JM0001511
2	1/2"-13 x 1-1/2" Gr5 Z Hex Bolt	JM0002100
3	1-1/2" Bore x 7" Stroke Hydraulic Cylinder (157HC)	JM0002882
4	535 Door Weldment	JM0026704

# Ladder

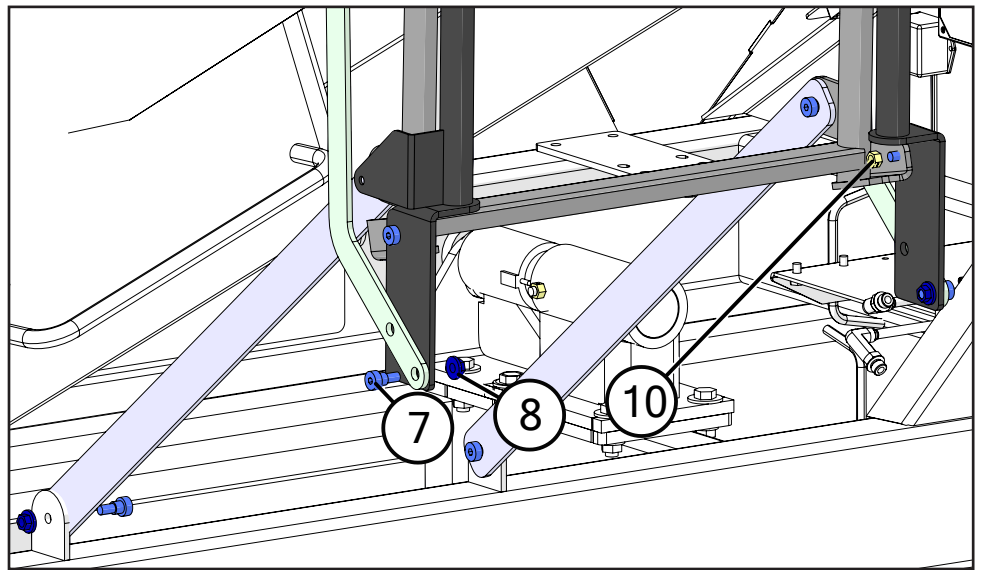
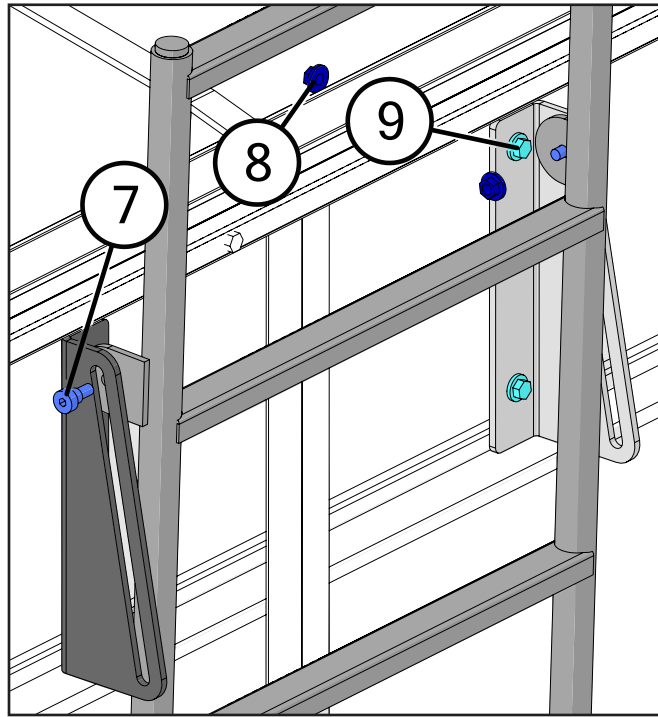
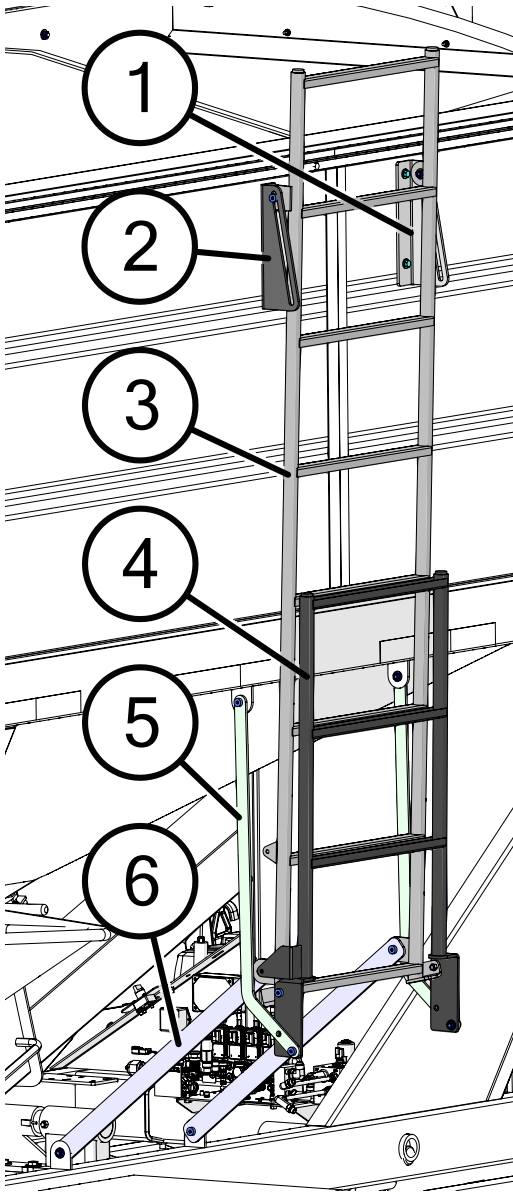

	Description	Part No.
1	Top Side Plate (Right) (535)	JM0031284
2	Top Side Plate (Left) (535)	JM0031175
3	535 Top Ladder Weldment	JM0031154
4	535 Lower Ladder Weldment	JM0031287
5	Curved Linkage	JM0031279
6	535 Ladder Brace	JM0041086
7	1/2" Shoulder Dia x 3/8" Shoulder Length x 3/8"-16 Socket Shoulder Bolt	JM0009998
8	3/8"-16 Gr5 Z SF Hex Nut	JM0002152
9	3/8"-16 x 1" Gr5 Z SF Hex Bolt	JM0002092
10	3/8"-16 Gr2 Z Centerlock Hex Nut	JM0001512

# Silver Hydraulic Valve JM0029973

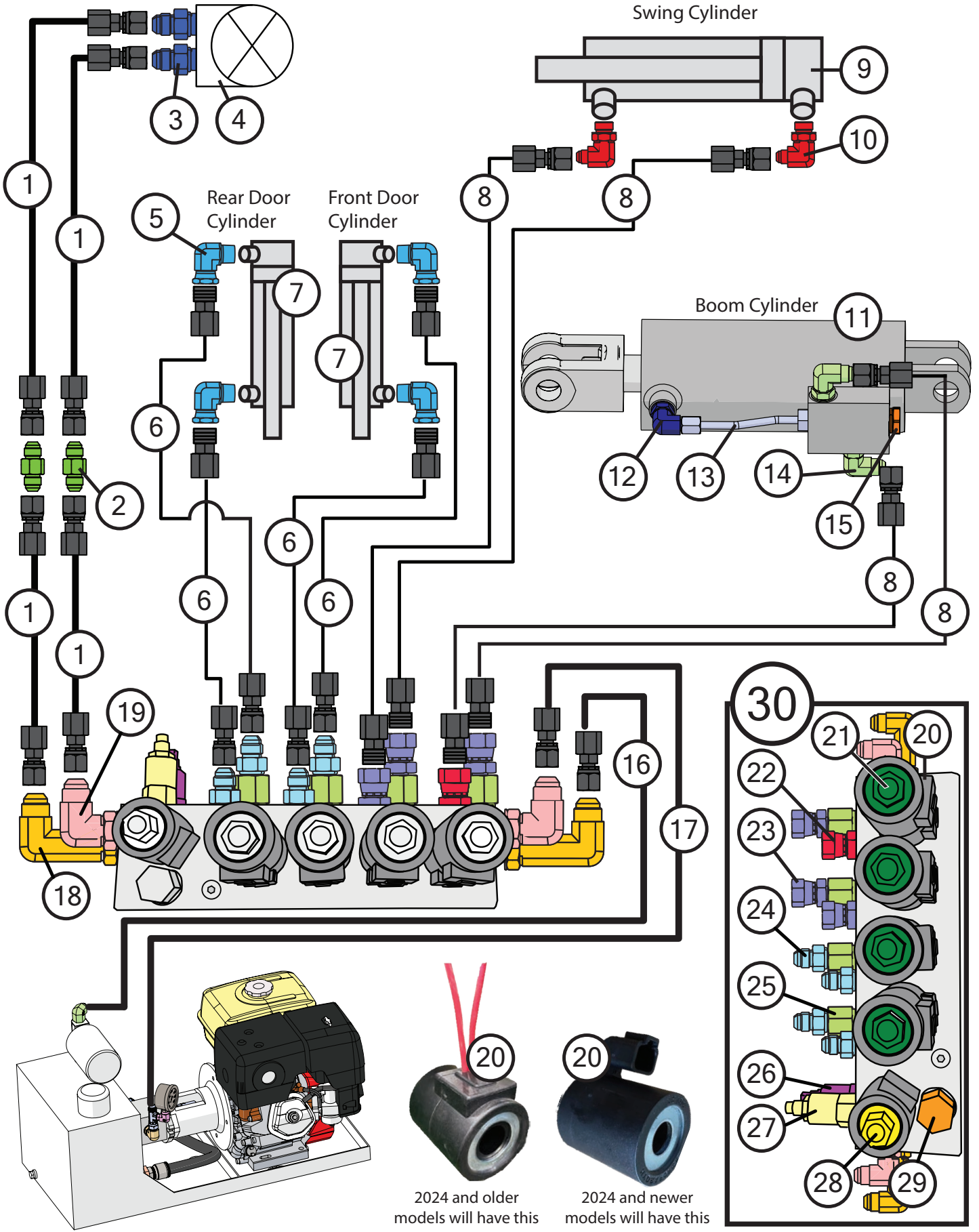



# Silver Hydraulic Valve JM0029973

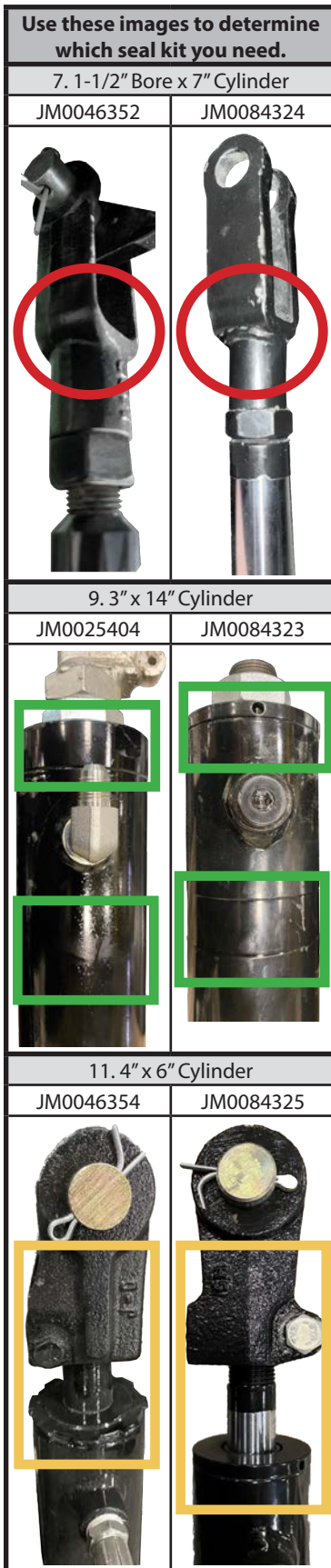

	Description	Part No.
1	1/2" x 210" Hydraulic Hose 210inch8M3k-8G-8FJX-8G-8FJX	JM0041443
2	1/2" Male JIC x 1/2" Male JIC; Straight	JM0041452
3	1/2" Male JIC x 1/2" Male NPT; Straight	JM0015201
4	WR Series Hydraulic Motor with Keyway and Pinhole (15100F30N6AAAAA)	JM0010469
4	Seal Kit for 15100F30N6AAAAA WR Series Hydraulic Motor	JM0042773
5	1/4" Male NPT x 1/4" Female NPT-Swivel; 90 Degree Elbow	JM0010301
6	1/4" x 194" Hydraulic Hose 194inch4M3k-4G-4MP-4G-6FJX	JM0010300
7	1-1/2" Bore x 7" Stroke Hydraulic Cylinder (157HC)	JM0002882
7	Seal Kit for 1-1/2" Bore x 7" Stroke Hydraulic Cylinder (JD571)	JM0046352
7	Seal Kit for 1-1/2" x 7" Tusker Welded Cylinder (104950-SKT)	JM0084324
8	1/4" x 194" Hydraulic Hose 194inch4M3k-4G-6MP-4G-6FJX	JM0041444
9	3" x 14" Welded Cylinder (No Clevis)	JM0041255
9	Seal Kit for 3" x 14" Welded Cylinder (No Clevis, JD-607)	JM0025404
9	Seal Kit for 3" x 14" Tusker Welded Cylinder (104951-SKT)	JM0084323
10	3/8" Male JIC x 1/2" Male ORB; 90 Degree Elbow	JM0037159
11	4" x 6" Welded Cylinder	JM0040425
11	Seal Kit for 4" x 5" Welded Cylinder (JD-576)	JM0046354
11	Seal Kit for 4" x 6" Tusker Welded Cylinder (104952-SKT)	JM0084325
12	#4 Male JIC x #6 Male ORB - Elbow	JM0079970
13	Steel Hose for PO Check	JM0079973
14	3/8" Male JIC x 3/8" Male ORB; 90 Degree Elbow	JM0026121
15	6 GPM PO Check Valve Cartridge (ST Boom Cylinder)	JM0082405
16	1/2" x 34" Hydraulic Hose 34inch8M3k-8G-8FJX-8G-8FJX	JM0025347
17	1/2" x 34" Hydraulic Hose 34inch8M3k-8G-6MPX-8G-8FJX	JM0010285
18	1/2" Male JIC x 1/2" Male ORB; Extra Long 90 Degree Elbow	JM0046935
19	1/2" Male JIC x 1/2" Male ORB; 90 Degree Elbow	JM0010297
20	Coil/Solenoid 6352012 (SL-1) with Bare Wires	JM0033735
20	Coil/Solenoid 4301612 with Deutsch Connector	JM0086383
21	Large Cartridge SV10-57 (Aluminum Valve Block)	JM0033737
22	3/8" Male ORB x 3/8" Female NPSM, 0.042 Restrictor; Straight (6900-06-06-R.042)	JM0033729
23	3/8" Male ORB x 3/8" Female NPSM Swivel; Straight	JM0044256
24	3/8" Male JIC x 3/8" Male ORB; Straight	JM0043614
25	3/8" Male ORB x 3/8" Female ORB; Straight Reducer	JM0039051
26	Relief Valve 1600 PSI (for Aluminum Valve Block) RV2	JM0033734
27	Relief Valve 1800 PSI (for Aluminum Valve Block) RV1	JM0033733
28	Hydraforce Proportional Cartridge - SP10-21-0-N-00	JM0086384
29	Logic Element - EP10-S35-0-N-80	JM0039058
30	Silver 5 Function Aluminum Manifold Valve Block	JM0029973

# Gold Hydraulic Valve JM0080426

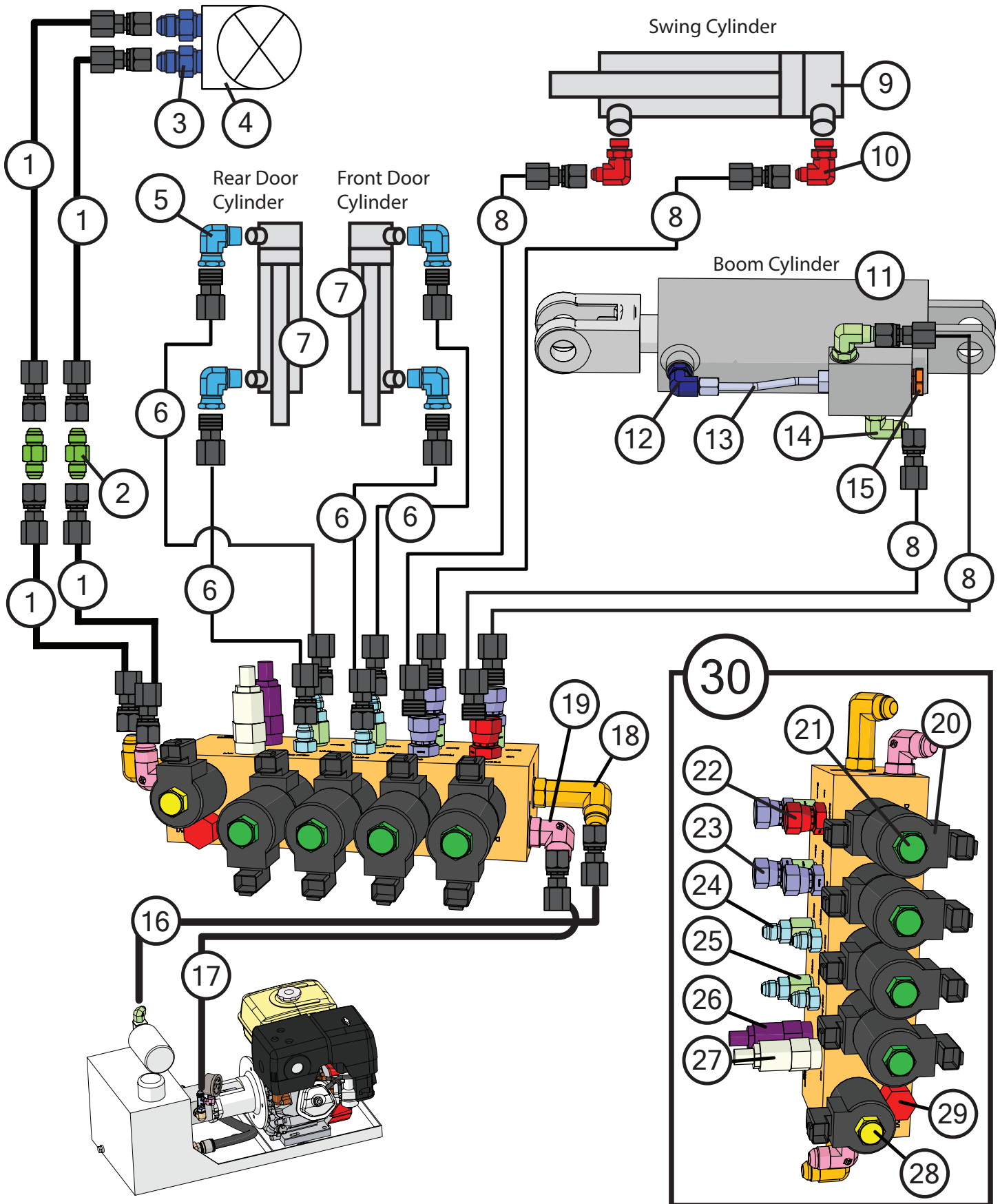

# Gold Hydraulic Valve JM0080426

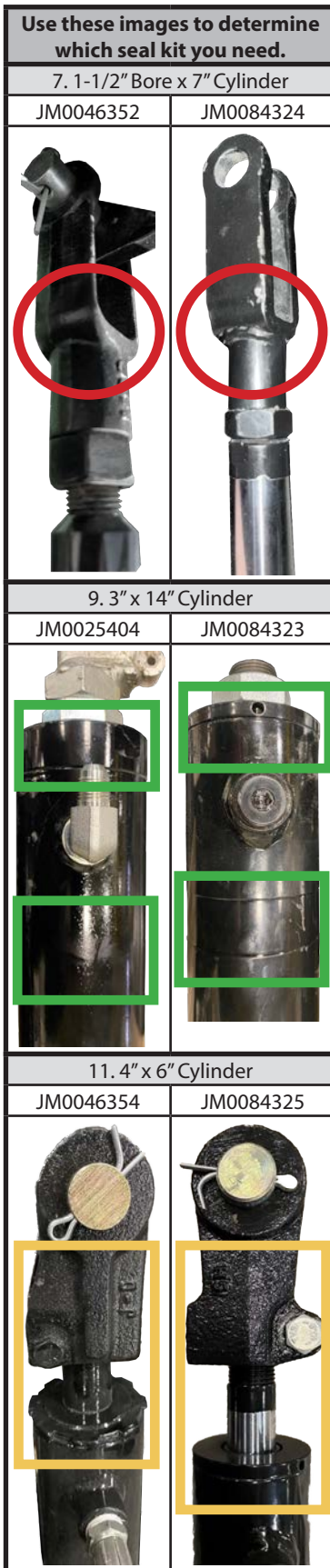

Description	Part No.
1 1/2" x 210" Hydraulic Hose 210inch8M3k-8G-8FJX-8G-8FJX	JM0041443
2 1/2" Male JIC x 1/2" Male JIC; Straight	JM0041452
3 1/2" Male JIC x 1/2" Male NPT; Straight	JM0015201
4 WR Series Hydraulic Motor with Keyway and Pinhole (15100F30N6AAAAA)	JM0010469
4 Seal Kit for 15100F30N6AAAAA WR Series Hydraulic Motor	JM0042773
5 1/4" Male NPT x 1/4" Female NPT-Swivel; 90 Degree Elbow	JM0010301
6 1/4" x 194" Hydraulic Hose 194inch4M3k-4G-4MP-4G-6FJX	JM0010300
7 1-1/2" Bore x 7" Stroke Hydraulic Cylinder (157HC)	JM0002882
7 Seal Kit for 1-1/2" Bore x 7" Stroke Hydraulic Cylinder (JD571)	JM0046352
7 Seal Kit for 1-1/2" x 7" Tusker Welded Cylinder (104950-SKT)	JM0084324
8 1/4" x 194" Hydraulic Hose 194inch4M3k-4G-6MP-4G-6FJX	JM0041444
9 3" x 14" Welded Cylinder (No Clevis)	JM0041255
9 Seal Kit for 3" x 14" Welded Cylinder (No Clevis, JD-607)	JM0025404
9 Seal Kit for 3" x 14" Tusker Welded Cylinder (104951-SKT)	JM0084323
10 3/8" Male JIC x 1/2" Male ORB; 90 Degree Elbow	JM0037159
11 4" x 6" Welded Cylinder	JM0040425
11 Seal Kit for 4" x 5" Welded Cylinder (JD-576)	JM0046354
11 Seal Kit for 4" x 6" Tusker Welded Cylinder (104952-SKT)	JM0084325
12 #4 Male JIC x #6 Male ORB - Elbow	JM0079970
13 Steel Hose for PO Check	JM0079973
14 3/8" Male JIC x 3/8" Male ORB; 90 Degree Elbow	JM0026121
15 6 GPM PO Check Valve Cartridge (ST Boom Cylinder)	JM0082405
16 1/2" x 34" Hydraulic Hose 34inch8M3k-8G-8FJX-8G-8FJX	JM0025347
17 1/2" x 34" Hydraulic Hose 34inch8M3k-8G-6MPX-8G-8FJX	JM0010285
18 1/2" Male JIC x 1/2" Male ORB; Extra Long 90 Degree Elbow	JM0046935
19 1/2" Male JIC x 1/2" Male ORB; 90 Degree Elbow	JM0010297
20 Comatrol Coil - M16-12D-26W-DE COIL	JM0081438
21 Comatrol Cartridge - SV10-35-02-12D-DE-B-00	JM0081439
22 3/8" Male ORB x 3/8" Female NPSM, 0.042 Restrictor; Straight (6900-06-06-R.042)	JM0033729
23 3/8" Male ORB x 3/8" Female NPSM Swivel; Straight	JM0044256
24 3/8" Male JIC x 3/8" Male ORB; Straight	JM0043614
25 3/8" Male ORB x 3/8" Female ORB; Straight Reducer	JM0039051
26 1600 PSI Comatrol Pressure Relief - CP210-2-B-0-A-C-160 RELIEF	JM0081443
27 1800 PSI Comatrol Pressure Relief - CP210-2-B-0-A-C-180 RELIEF	JM0081442
28 Comatrol Cartridge - PSVP10-NOR-12D-DE-B-00	JM0081440
29 Comatrol Logic Element - CP700-2-B-0-080	JM0081441
30 Gold 5 Function Aluminum Valve Block and Fittings	JM0080426

# Blue Hydraulic Valve JM0080825

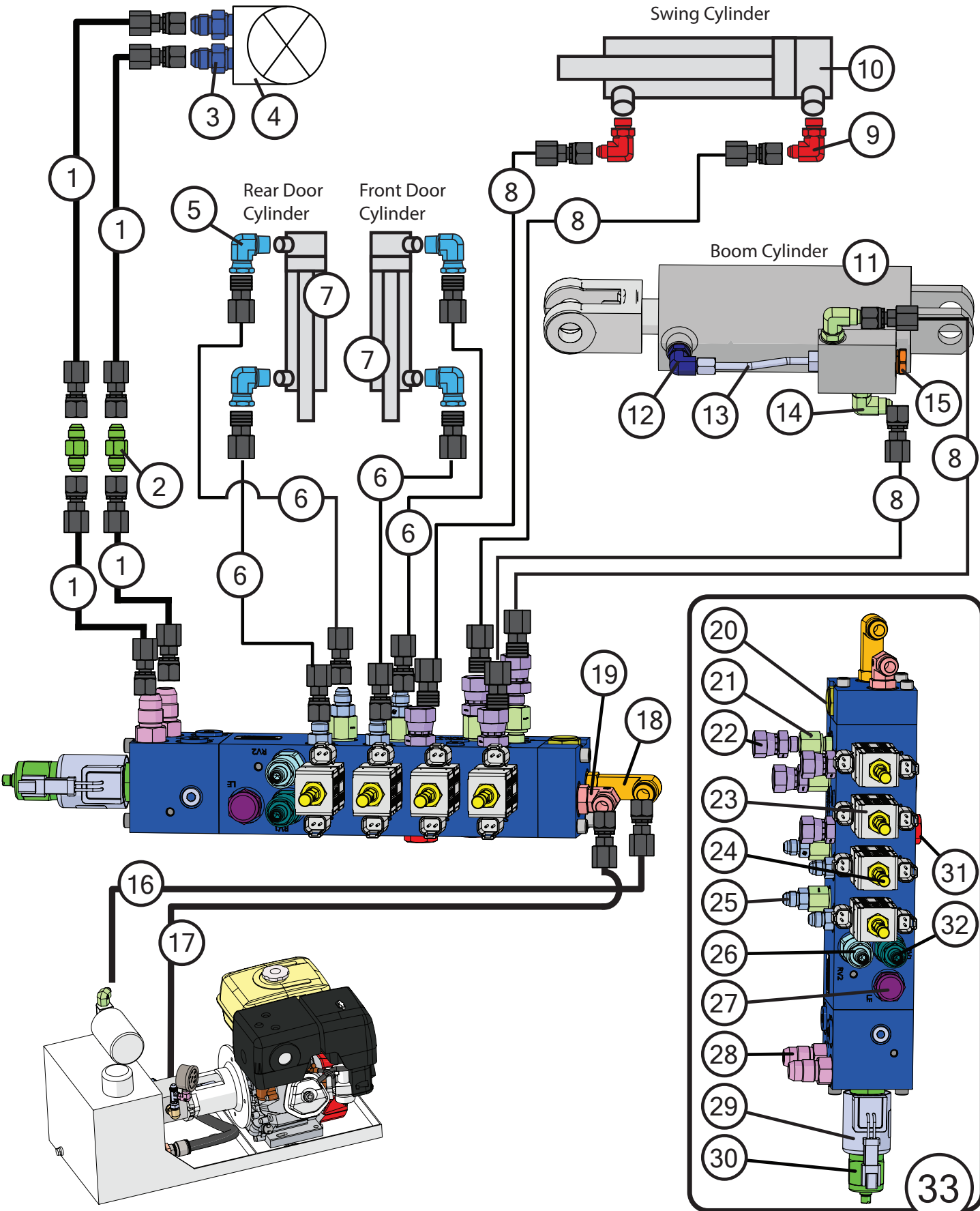

# Blue Hydraulic Valve JM0080825

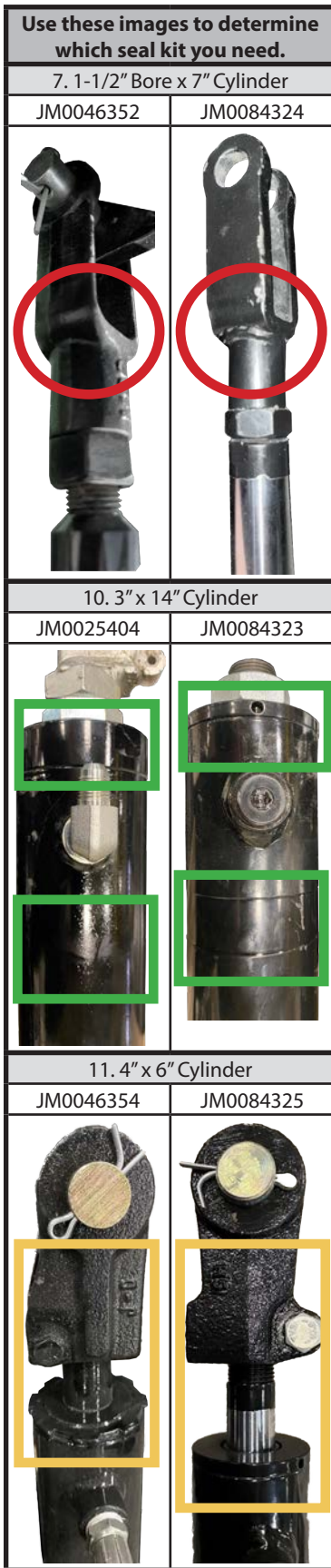

Description	Part No.
1 1/2" x 210" Hydraulic Hose 210inch8M3k-8G-8FJX-8G-8FJX	JM0041443
2 1/2" Male JIC x 1/2" Male JIC; Straight	JM0041452
3 1/2" Male JIC x 1/2" Male NPT; Straight	JM0015201
4 WR Series Hydraulic Motor with Keyway and Pinhole (15100F30N6AAAAA)	JM0010469
4 Seal Kit for 15100F30N6AAAAA WR Series Hydraulic Motor	JM0042773
5 1/4" Male NPT x 1/4" Female NPT-Swivel; 90 Degree Elbow	JM0010301
6 1/4" x 194" Hydraulic Hose 194inch4M3k-4G-4MP-4G-6FJX	JM0010300
7 1-1/2" Bore x 7" Stroke Hydraulic Cylinder (157HC)	JM0002882
7 Seal Kit for 1-1/2" Bore x 7" Stroke Hydraulic Cylinder (JD571)	JM0046352
7 Seal Kit for 1-1/2" x 7" Tusker Welded Cylinder (104950-SKT)	JM0084324
8 1/4" x 194" Hydraulic Hose 194inch4M3k-4G-6MP-4G-6FJX	JM0041444
9 3/8" Male JIC x 1/2" Male ORB; 90 Degree Elbow	JM0037159
10 3" x 14" Welded Cylinder (No Clevis)	JM0041255
10 Seal Kit for 3" x 14" Welded Cylinder (No Clevis, JD-607)	JM0025404
10 Seal Kit for 3" x 14" Tusker Welded Cylinder (104951-SKT)	JM0084323
11 4" x 6" Welded Cylinder	JM0040425
11 Seal Kit for 4" x 5" Welded Cylinder (JD-576)	JM0046354
11 Seal Kit for 4" x 6" Tusker Welded Cylinder (104952-SKT)	JM0084325
12 #4 Male JIC x #6 Male ORB - Elbow	JM0079970
13 Steel Hose for PO Check	JM0079973
14 3/8" Male JIC x 3/8" Male ORB; 90 Degree Elbow	JM0026121
15 6 GPM PO Check Valve Cartridge (ST Boom Cylinder)	JM0082405
16 1/2" x 34" Hydraulic Hose 34inch8M3k-8G-8FJX-8G-8FJX	JM0025347
17 1/2" x 34" Hydraulic Hose 34inch8M3k-8G-6MPX-8G-8FJX	JM0010285
18 1/2" Male JIC x 1/2" Male ORB; Extra Long 90 Degree Elbow	JM0046935
19 1/2" Male JIC x 1/2" Male ORB; 90 Degree Elbow	JM0010297
20 Eaton Cartridge for Force America Valve Bank 02-186758	JM0081539
21 3/8" Male ORB x 3/8" Female ORB; Straight Reducer	JM0039051
22 3/8" Male ORB x 3/8" Female NPSM Swivel; Straight	JM0044256
23 Position Coil/Solenoid Hydraulic (Swing/Doors/Boom) for Blue Force America Valve	JM0081538
24 Position Cartridge (Swing/Doors/Boom) Blue Force America Valve (10193-69)	JM0081513
25 3/8" Male JIC x 3/8" Male ORB; Straight	JM0043614
26 Pressure Relief Valve for Blue Force America Valve RV2 1600 (RD102530)	JM0081637
27 Logic Element for Blue Force America (565604)	JM0081514
28 1/2" Male JIC x 1/2" Male O-ring; Straight	JM0010293
29 Conveyor Coil/Solenoid for Blue Force America Valve (MCSC012DCE06)	JM0081507
30 Conveyor Position Cartridge for Blue Force America Valve (EFV2-12N-CAF-00)	JM0081512
31 Check Valve for Blue Force America Valve (4CK301S16)	JM0081531
32 Pressure Relief Valve for Blue Force America Valve RV1 1800	JM0081506
33 Blue 5 Function Aluminum Valve Block Assembly with Fittings	JM0080825

# Talc Applicator

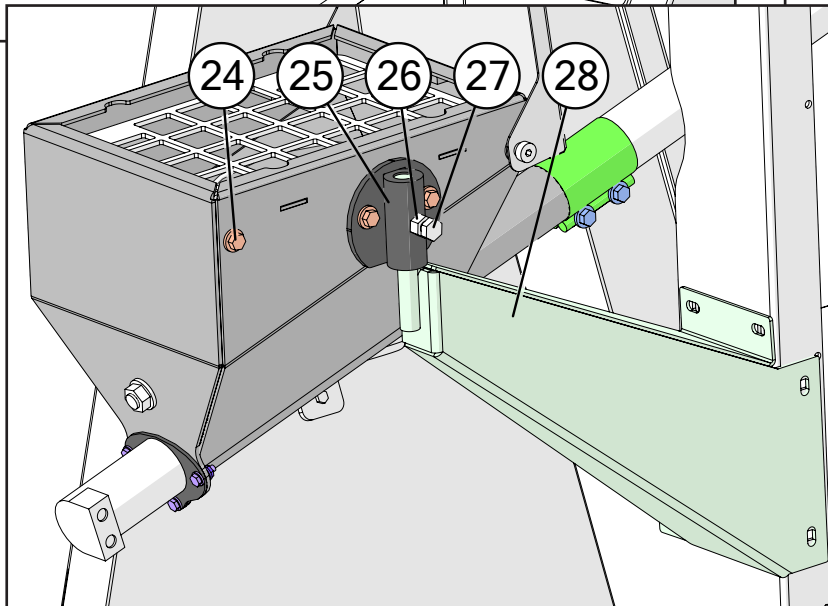
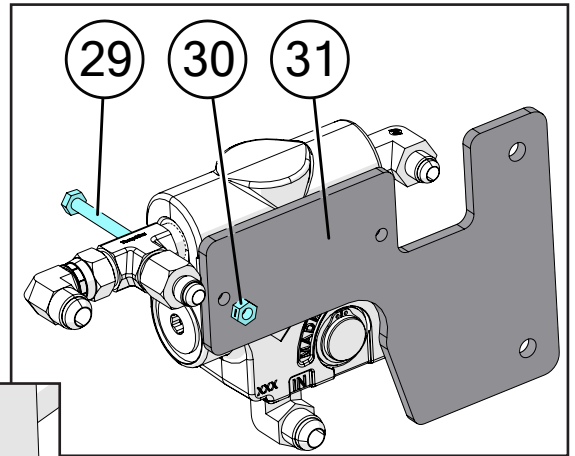
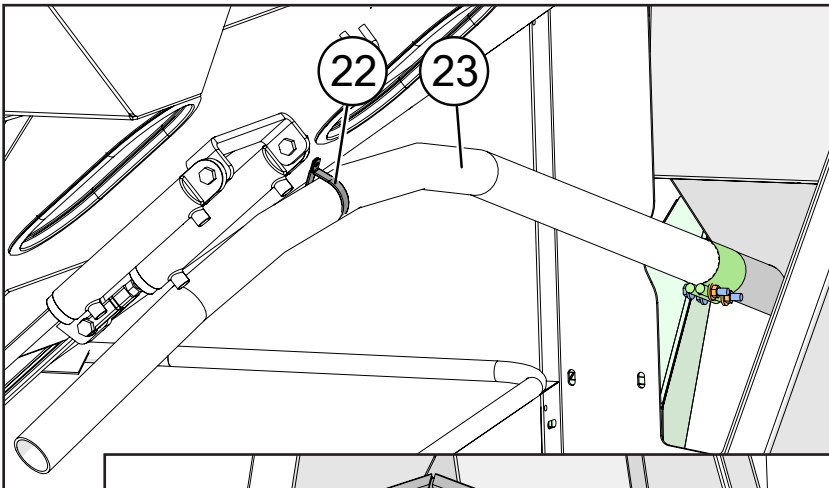
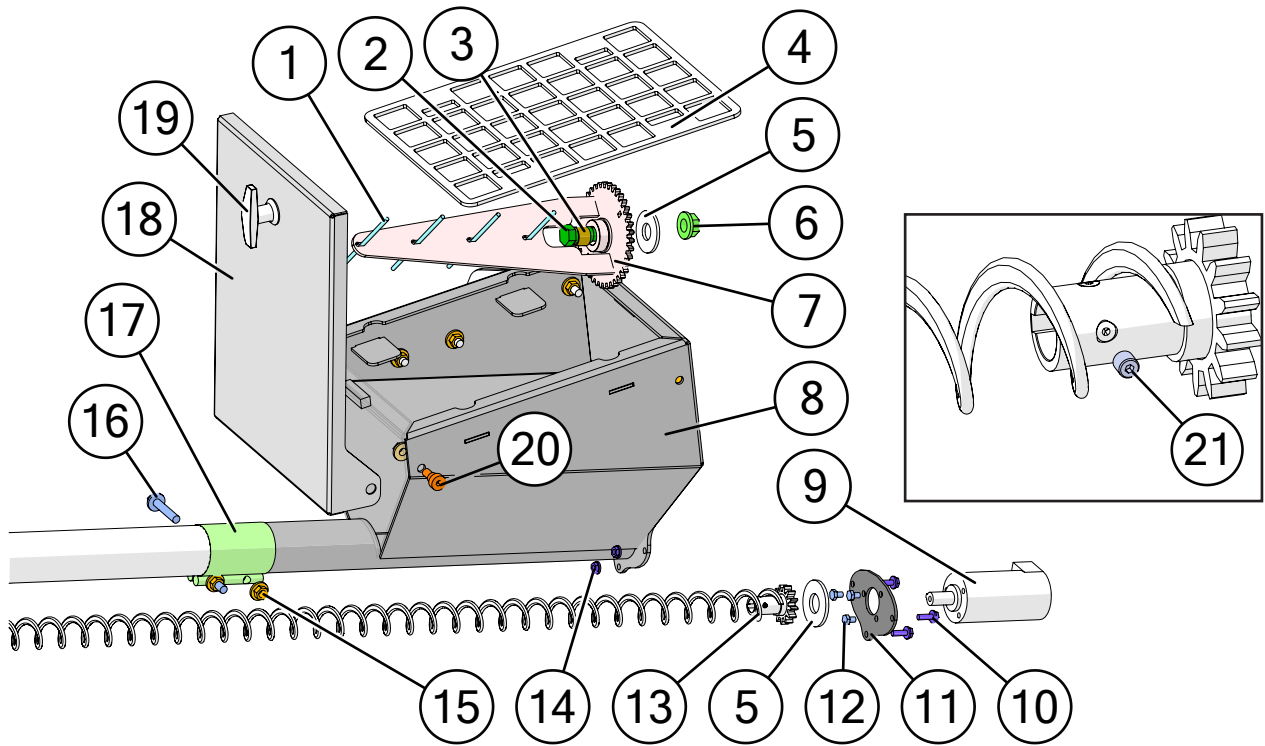

# Talc Applicator

	Description	Part No.
1	3/16" Nylon Rod for Talc Agitator	JM0062689
2	3/4" Shoulder Dia x 1" Shoulder Length x 5/8"-11 Hex Head Shoulder Bolt and Nut (SB-34)	JM0003181
3	3/4" ID x 7/8" OD x 5/8" LG Bronze Bushing (BB-34)	JM0009455
4	Large Talc Box Screen (Electric & Hydraulic Motor)	JM0037456
5	3/4" USS Z Flat Washer	JM0010006
6	5/8"-18 Gr5 Z SF Hex Nut	JM0043101
7	Large Agitator 17 Deg. (Electric & Hydraulic Motor)	JM0037241
8	17 Deg. Talc Box Weldment (Electric & Hydraulic Motor)	JM0037538
9	White Drive Hydraulic Motor - 125032JL5C3AAAAA	JM0042491
10	1/4"-20 x 3/4" Gr5 Z SF Hex Bolt	JM0001642
11	Flange Plate for Talc Hydraulic Motor	JM0059070
12	1/4"-28 x 3/8" Gr5 Z Hex Bolt	JM0043100
13	535, c450, 51 Series Flex Auger Flighting Weldment 88-5/8" 2020 and Newer	JM0083248
14	1/4"-20 Gr5 Z SF Hex Nut	JM0001630
15	3/8"-16 Gr5 Z SF Hex Nut	JM0002152
16	3/8"-16 x 2" Gr5 Z SF Hex Bolt	JM0016070
17	2" Exhaust Clamp with Fasteners (Electric & Hydraulic Motor)	JM0037668
18	17 Deg. Talc Box Door (Electric & Hydraulic Motor)	JM0037237
19	Chrome T-Handle Non-Locking	JM0001911
20	1/2" Shoulder Dia x 3/8" Shoulder Length x 3/8"-16 Socket Shoulder Bolt	JM0009998
21	10-32 x 1/4" Cup-Point Set Screw	JM0076511
22	2" Pipe Loop Clamp	JM0043498
23	Flex Auger Heat Bent PVC Pipe, 535, c450, 51 Series	JM0043049
24	3/8"-16 x 1" Gr5 Z SF Hex Bolt	JM0002092
25	Talc Rotation Bracket Weldment (Electric & Hydraulic Motor)	JM0038395
26	1/2"-13 Gr2 Z Hex Nut	JM0002124
27	1/2"-13 x 1" Gr5 Z Hex Bolt	JM0010225
28	510, 535 Talc Mounting Bracket Weldment (Chain and Hydraulic)	JM0037641
29	1/4"-20 x 2-1/2" Gr5 Z Hex Bolt	JM0001506
30	1/4"-20 Gr2 Z Centerlock Hex Nut	JM0001505
31	535 Bolt on Plate Talc Valve	JM0025400

# Talc Hydraulics Schematic for Aluminum Valve

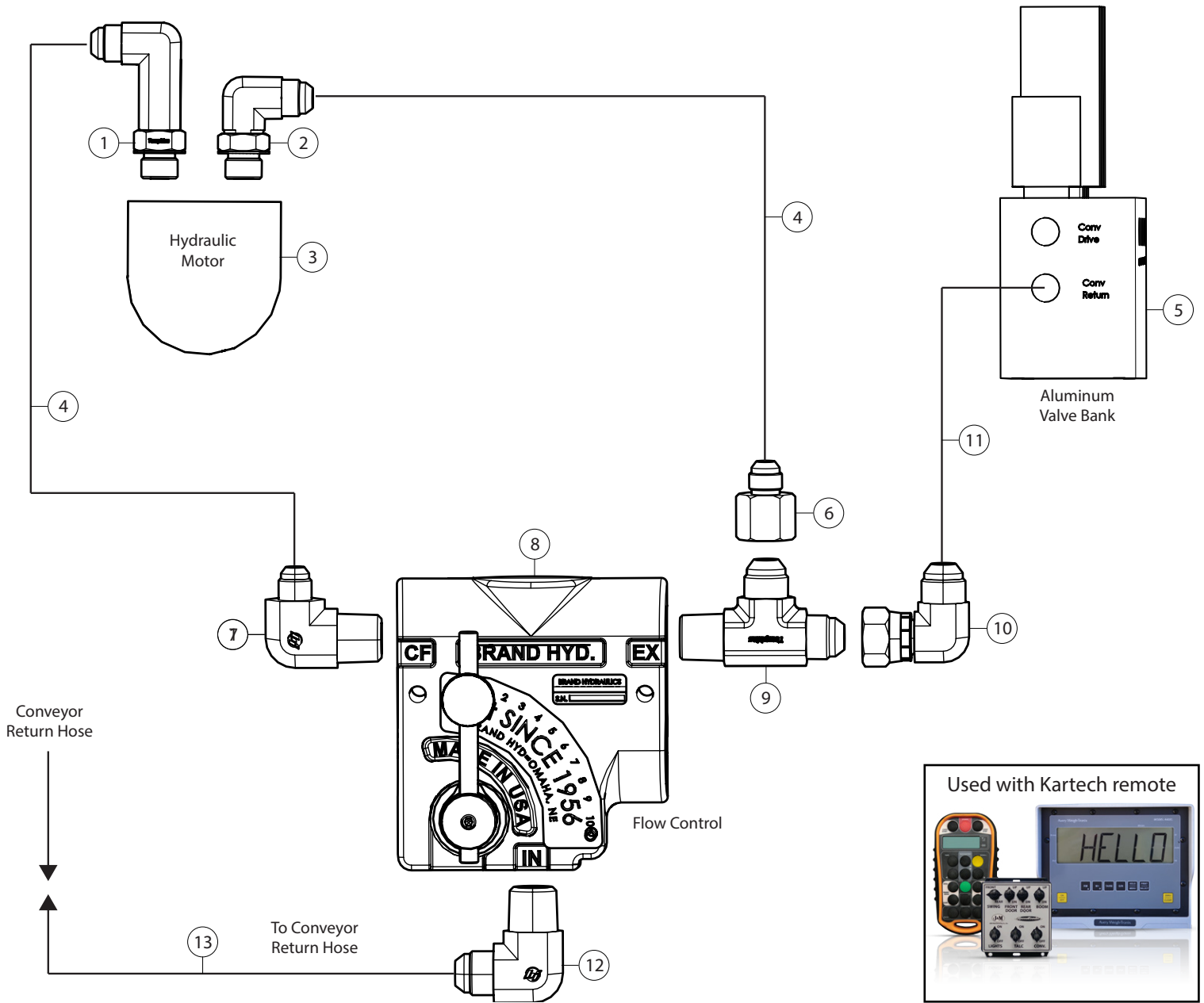

Description	Part No.
1 3/8" Male JIC x 3/8" Male ORB; Extra Long 90 Degree Elbow	JM0039050
2 3/8" Male JIC x 3/8" Male ORB; 90 Degree Elbow	JM0026121
3 White Drive Hydraulic Motor - 125032JL5C3AAAAA	JM0042491
4 1/4" x 194" Hydraulic Hose - 194inch4CR1-4G-6FJX-4G-6FJX	JM0086372
5 Silver 5 Function Aluminum Manifold Valve Block	JM0029973
6 1/2" Female JIC x 3/8" Male JIC Reducer	JM0026117
7 3/8" Male JIC x 1/2" Male NPT; 90 Degree Elbow	JM0042849
8 Flow Control Talc Applicator FC51 - .5 (0-2 GPM)	JM0026104
9 1/2" Male JIC x 1/2" Male NPT x 1/2" Male JIC Tee	JM0026119
10 1/2" Male JIC x 1/2" Female JIC Swivel; 90 Degree Elbow (6500-08-08)	JM0010296
11 1/2" x 30" Hydraulic Hose 30inch8M3K-8G-8FJX-8G-8FJX	JM0042863
12 1/2" Male JIC x 1/2" Male NPT; 90 Degree Elbow	JM0042847
13 1/2" x 20" Hydraulic Hose 20inch8M3K-8G-8MJ-8G-8FJX	JM0042862



# Electronic Talc Hydraulics Schematic for Silver and Gold Valves

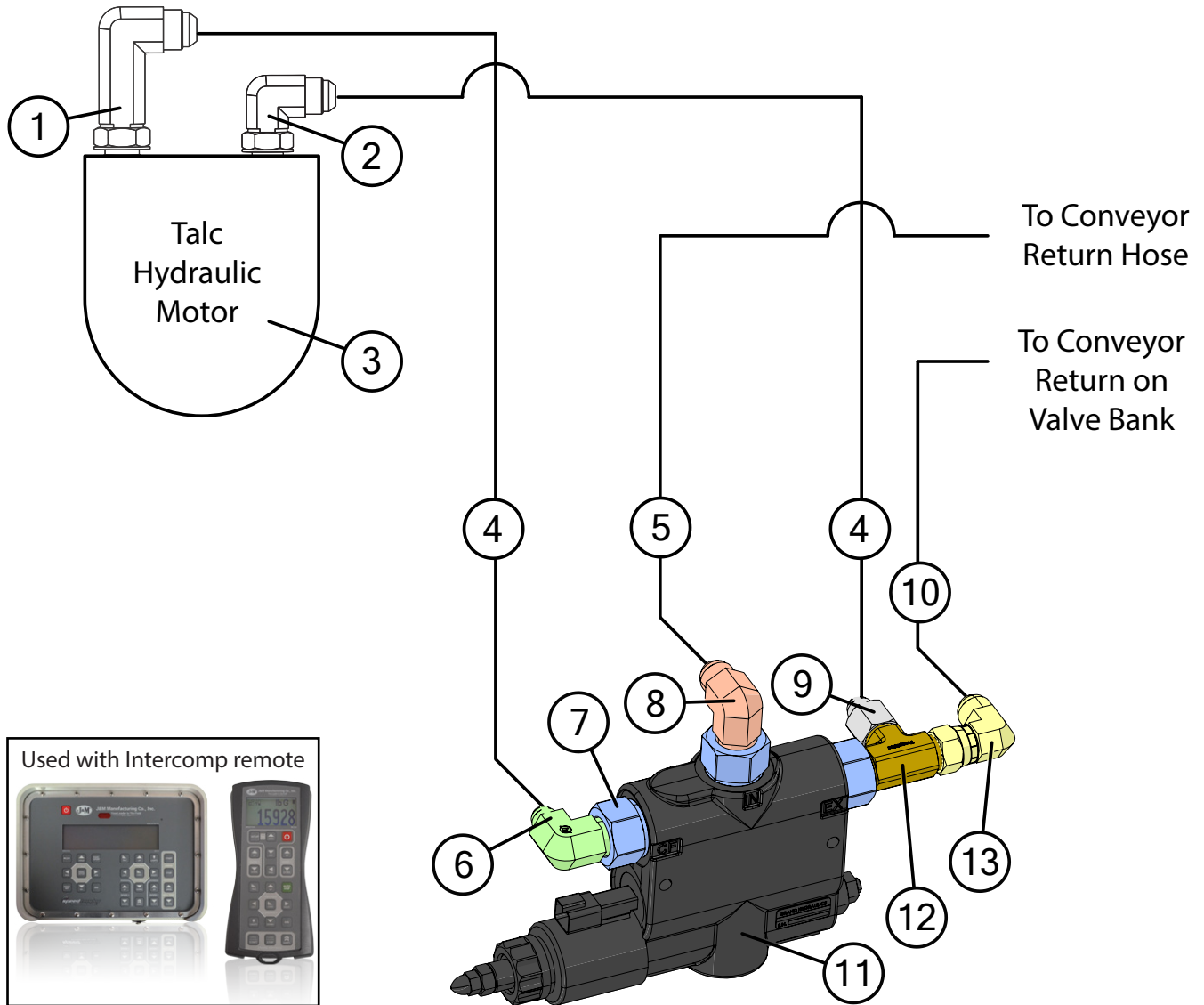

Description	Part No.
1 3/8" Male JIC x 3/8" Male ORB; Extra Long 90 Degree Elbow	JM0039050
2 3/8" Male JIC x 3/8" Male ORB; 90 Degree Elbow	JM0026121
3 White Drive Hydraulic Motor - 125032JL5C3AAAAA	JM0042491
4 1/4" x 194" Hydraulic Hose - 194inch4CR1-4G-6FJX-4G-6FJX	JM0086372
5 1/2" x 20" Hydraulic Hose 20inch8M3K-8G-8MJ-8G-8FJX	JM0042862
6 3/8" Male JIC x 1/2" Male NPT; 90 Degree Elbow	JM0042849
7 #12 Male ORB x #8 Female NPT - Straight	JM0080923
8 1/2" Male JIC x 1/2" Male NPT; 90 Degree Elbow	JM0042847
9 1/2" Female JIC x 3/8" Male JIC Reducer	JM0026117
10 1/2" x 30" Hydraulic Hose 30inch8M3K-8G-8FJX-8G-8FJX	JM0042863
11 Brand EFC Talc Valve 0-5 GPM	JM0080429
12 1/2" Male JIC x 1/2" Male NPT x 1/2" Male JIC Tee	JM0026119
13 1/2" Male JIC x 1/2" Female JIC Swivel; 90 Degree Elbow (6500-08-08)	JM0010296

# Electronic Talc Hydraulics Schematic for Blue Valve

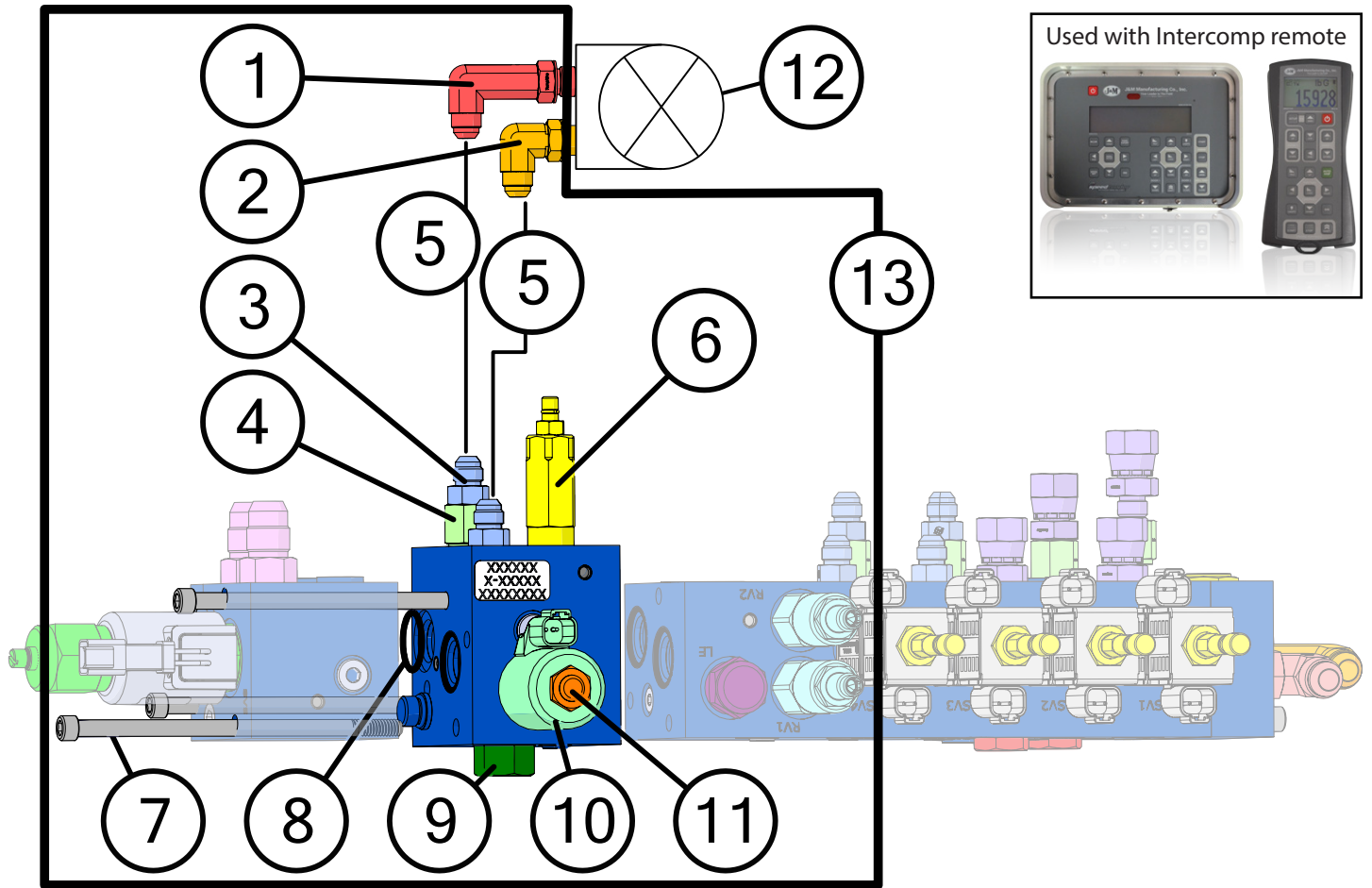

Description	Part No.
1 3/8" Male JIC x 3/8" Male ORB; Extra Long 90 Degree Elbow	JM0039050
2 3/8" Male JIC x 3/8" Male ORB; 90 Degree Elbow	JM0026121
3 3/8" Male JIC x 3/8" Male ORB; Straight	JM0043614
4 3/8" Male ORB x 3/8" Female ORB; Straight Reducer	JM0039051
5 1/4" x 84" Hydraulic Hose 84inch4M3K-4G-6FJX-4G-6FJX	JM0051419
6 Talc Pressure Relief Valve for Blue Force America Valve (RV1-8-S-0-36)	JM0081542
7 5/16"-18 x 6-1/2" Socket Head Cap Screw	JM0081547
8 O-Ring Between Force America Valve Banks	JM0051416
9 Talc Check Valve for Blue Force America Valve (PCS4-10-0-80)	JM0081543
10 Talc Coil/Solenoid for Blue Force America (MCSCJ012DN000010)	JM0081544
11 Talc Cartridge Proportional for Blue Force America (ESV1-10-C-0-00)	JM0081546
12 White Drive Hydraulic Motor - 125032JL5C3AAAAA	JM0042491
13 Full Talc Block Assembly with Hoses and Loose Parts	JM0080827

# Spring Return

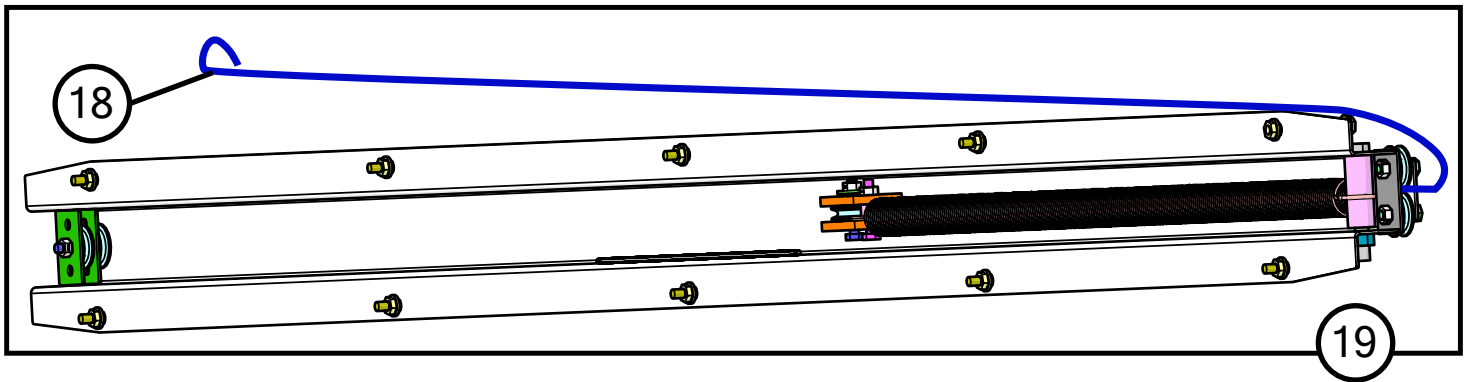
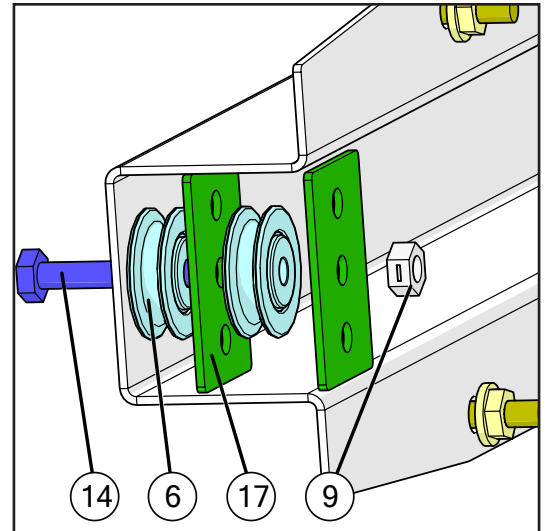
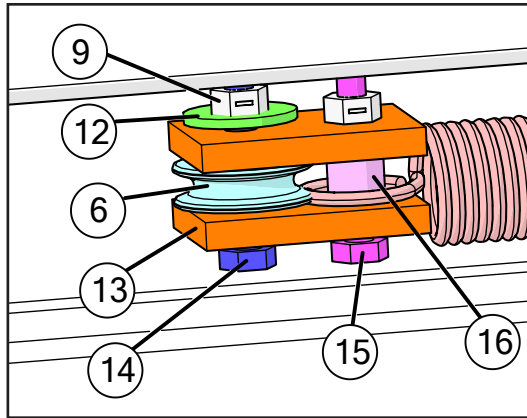
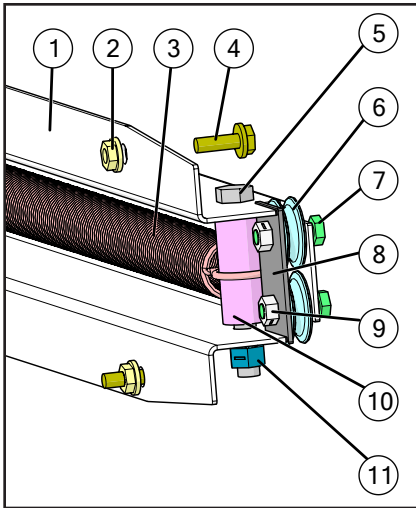

	Description	Part No.
1	Spring Return Housing for Seed Tender and Gravity Box Roll Tarp	JM0002446
2	1/4"-20 Gr5 Z SF Hex Nut	JM0001630
3	Spring Return Spring	JM0000207
4	1/4"-20 x 3/4" Gr5 Z SF Hex Bolt	JM0001642
5	3/8"-16 x 3" Gr5 Z Hex Bolt	JM0001666
6	1-1/4" Idler Pulley (1/4" ID)	JM0002439
7	1/4"-20 x 3/4" Gr5 Z Hex Bolt	JM0001507
8	Spring Return Pulley Brace Plate	JM0013484
9	1/4"-20 Gr2 Z Centerlock Hex Nut	JM0001505
10	3/4" x 2" Plastic Spacer	JM0002444
11	3/8"-16 Gr2 Z Centerlock Hex Nut	JM0001512
12	1/4" ID, 3/4" OD Z Flat Washer	JM0003090
13	1/4" x 1-1/2" x 2" Plastic Spacer - 2 Hole (Seed Tender and Gravity Box)	JM0002443
14	1/4"-20 x 1-1/2" Gr5 Z Hex Bolt	JM0002447
15	1/4"-20 x 1" Gr5 Z Hex Bolt	JM0002095
16	2" Black Plastic Spacer (1/4" ID x 1/2" OD)	JM0002442
17	Aluminum Spacer for Spring Return (1-3/8" x 2-3/16") Rectangular	JM0002445
18	Spring Return Cable (Seed Tender and Gravity Boxes)	JM0010307
19	Spring Return Assembly for Seed Tenders and Gravity Boxes (ST375TSW)	JM0002437

# Roll Tarp

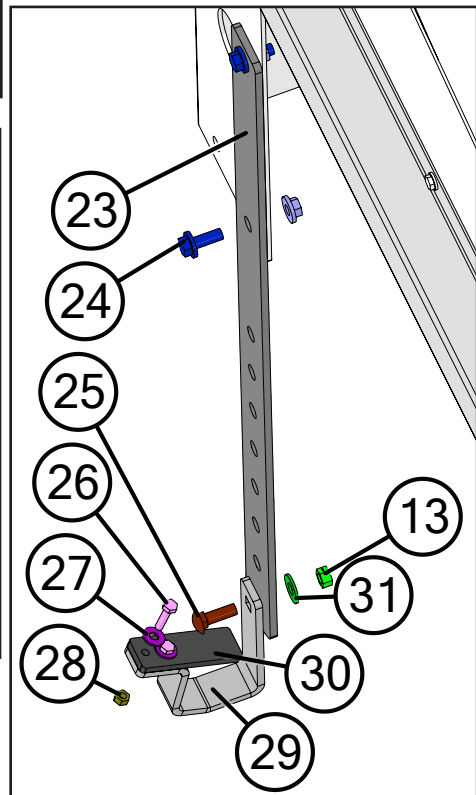
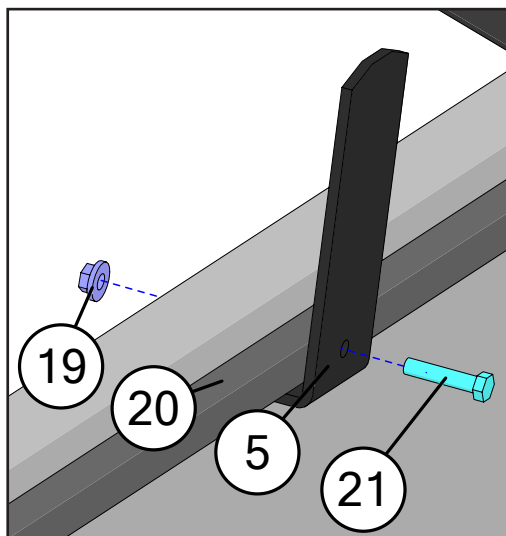
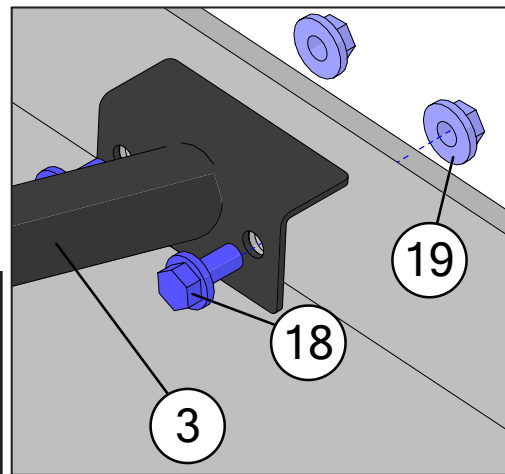
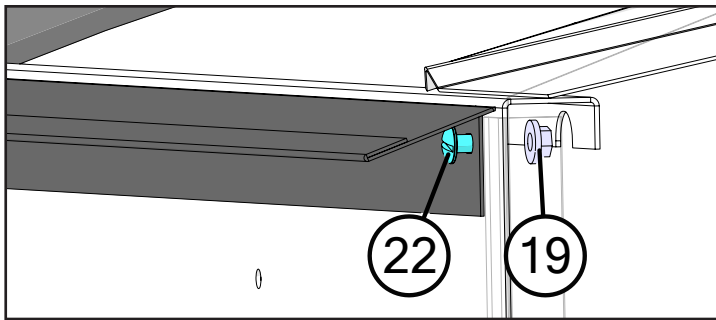
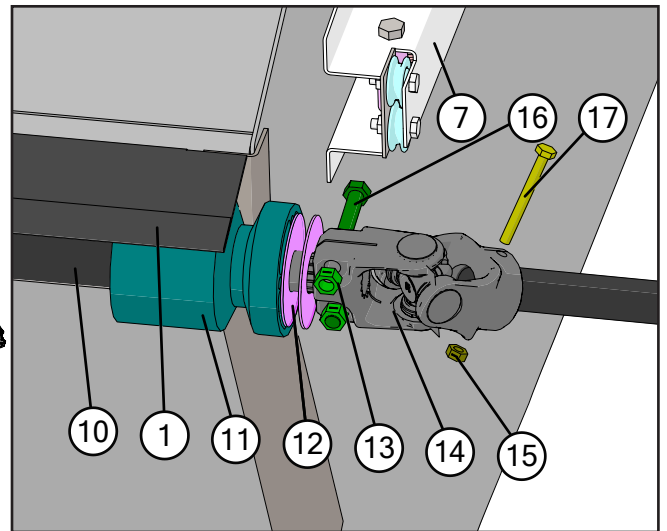
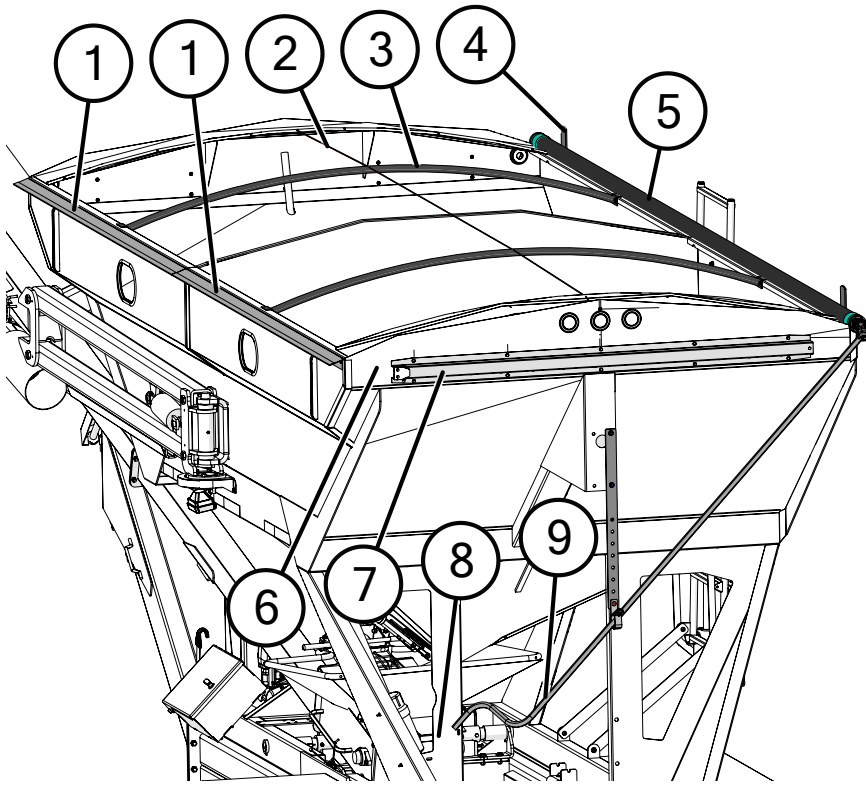

# Roll Tarp

	Description	Part No.
1	Lip Lock (535)	JM0026788
2	Ridge Cable for 500ST	JM0016622
3	Tarp Bow Weldment (535)	JM0026952
4	Tarp Stop	JM0002448
5	500 ST Tarp, Black, 18 oz. Vinyl, with Rivets	JM0015905
6	Spring Return Assembly for Seed Tenders and Gravity Boxes (ST375TSW)	JM0002437
7	Spring Return Cable (Seed Tender and Gravity Boxes)	JM0010307
8	S-Cap Yellow - 1.062" ID x 1-1/2" x 1/16"	JM0018963
9	93-1/4" Crank Handle (ST375CH)	JM0002907
10	Roll Pipe Weldment (535)	JM0013891
11	Roll Tarp Guide Roller (4-1/8" Long x 3-1/4" O.D.)	JM0038446
12	1" USS Flat Washer	JM0003063
13	3/8"-16 Gr2 Z Centerlock Hex Nut	JM0001512
14	Universal Joint - Roll Tarp (SUJ-1)	JM0001517
15	1/4"-20 Gr2 Z Centerlock Hex Nut	JM0001505
16	3/8"-16 x 1-1/2" Gr5 Z Hex Bolt	JM0001659
17	1/4"-20 x 2-1/2" Gr5 Z Hex Bolt	JM0001506
18	3/8"-16 x 3/4" Gr5 Z SF Hex Bolt	JM0001750
19	3/8"-16 Gr5 Z SF Hex Nut	JM0002152
20	Tarp Tube 1"x1" (535)	JM0013896
21	3/8"-16 x 1-3/4" Gr5 Z Hex Bolt	JM0002097
22	3/8"-16 x 1" Gr5 Z Pan Head Bolt	JM0002892
23	Tarp Handle Hanger Mount (1000 bu. and up)(34" L)	JM0036728
24	3/8"-16 x 1" Gr5 Z SF Hex Bolt	JM0002092
25	3/8"-16 x 1-1/4" Gr5 Z Carriage Bolt	JM0001639
26	1/4"-20 x 1" Gr5 Z Hex Bolt	JM0002095
27	1/4" Z Flat Washer	JM0076815
28	1/4"-20 Gr2 Z Centerlock Hex Nut	JM0001505
29	Crank Handle Hook	JM0081371
30	Roll Tarp Handle Top Hook (3-3/4" x 1-1/4" Black UHMW)	JM0084401
31	3/8" USS Flat Washer	JM0003061