



Manual

TRACKS

OPERATOR'S MANUAL

MODEL **stabilizer**
Trax 2-46"

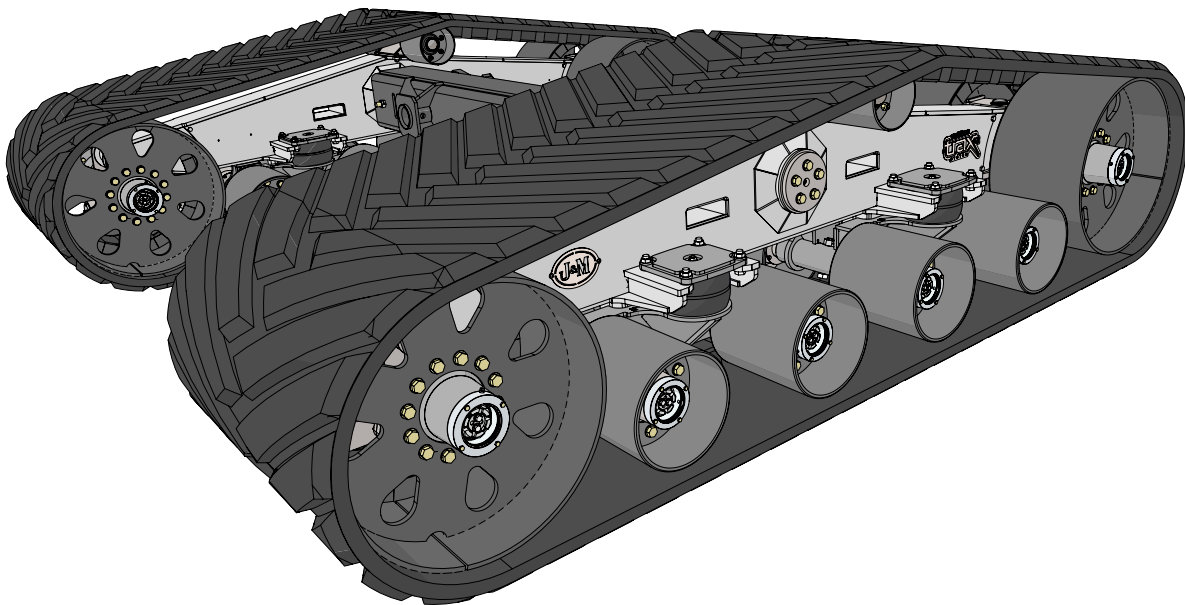

Rev. 5.13.2024

J&M Manufacturing Co, Inc

284 Railroad Street - P.O. Box 547 | Fort Recovery, OH 45846 | Ph: (419) 375-2376 | Fax: (419) 375-2708
www.jm-inc.com

Table of Contents

To the Dealer	4
Serial Number	5
General Information	6
Safety Rules.....	7
Specifications.....	7
Bolt Torque Chart	8
Castle Nut Torque Setting	9
Lubrication Schedule.....	9
Routine Maintenance	10
Alignment	11
Service	12
Installation	17
Operation Guidelines	18
Repair Parts List and Diagrams	
Decals	19
Track Beam Connections and Wheels	20
End Idler Hub and Spindle Assembly.....	22
Midroller Hub and Spindle Assembly	23
Tensioner	24
Spring and Midrollers	25
Hitch	26
Upper Rollers	27
7" Assembly Aid.....	28

To the Dealer

TO THE DEALER

Read manual instructions and safety rules. Make sure all items on the Dealer's Pre-Delivery and Delivery Check Lists are completed before releasing equipment to the owner.

The dealer must complete the Warranty Registration found on the Dealer Portal website located at dealer.jm-inc.com and return it to J&M Mfg. Co., Inc. at the address indicated on the form. Warranty claims will be denied if the Warranty Registration has not been submitted.

EXPRESS WARRANTY:

J&M Mfg. Co. Inc. warrants against defects in construction or materials for a period of ONE year. We reserve the right to inspect and decide whether material or construction was faulty or whether abuse or accident voids our guarantee.

Warranty service must be performed by a dealer or service center authorized by J&M Mfg. Co., Inc. to sell and/or service the type of product involved, which will use only new or remanufactured parts or components furnished by J&M Mfg. Co., Inc. Warranty service will be performed without charge to the purchaser for parts or labor based on the Warranty Labor Times schedule. Under no circumstance will allowable labor times extend beyond the maximum hours indicated in the Warranty Labor Times schedule for each warranty procedure. The purchaser will be responsible, however, for any service call and/or transportation of the product to and from the dealer or service center's place of business, for any premium charged for overtime labor requested by the purchaser, and for any service and/or maintenance not directly related to any defect covered under the warranty. Costs associated with equipment rental, product down time, or product disposal are not warrantable and will not be accepted under any circumstance.

Each warranty term begins on the date of product delivery to the purchaser. Under no circumstance will warranty be approved unless (i) the product warranty registration card has been properly completed and submitted to the equipment manufacturer, and (ii) a warranty authorization number has been issued by the equipment manufacturer. This Warranty is effective only if the warranty registration card is returned within 30 days of purchase.

This warranty does not cover a component which fails, malfunctions or is damaged as a result of (i) improper modification or repair, (ii) accident, abuse or improper use, (iii) improper or insufficient maintenance, or (iv) normal wear or tear. This warranty does not cover products that are previously owned and extends solely to the original purchaser of the product. Should the original purchaser sell or otherwise transfer this product to a third-party, this warranty does not transfer to the third party purchaser in any way. J&M Mfg. Co., Inc. makes no Warranty, express or implied, with respect to tires or other parts or accessories not manufactured by J&M Mfg. Co., Inc. Warranties for these items, if any, are provided separately by their respective manufacturers.

THIS WARRANTY IS EXPRESSLY IN LIEU OF ALL OTHER WARRANTIES OR CONDITIONS, EXPRESS, IMPLIED OR STATUTORY, INCLUDING ANY IMPLIED WARRANTY OF MERCHANTABILITY OR FITNESS FOR PARTICULAR PURPOSE.

In no event shall J&M Mfg. Co., Inc. be liable for special, direct, incidental or consequential damages of any kind. The exclusive remedy under this Warranty shall be repair or replacement of the defective component at J&M Mfg. Co., Inc.'s option. This is the entire agreement between J&M Mfg. Co., Inc. and the Owner about warranty and no J&M Mfg. Co., Inc. employee or dealer is authorized to make any additional warranty on behalf of J&M Mfg. Co., Inc.

The manufacturer reserves the right to make product design and material changes at any time without notice. They shall not incur any obligation or liability to incorporate such changes and improvements in products previously sold to any customer, nor shall they be obligated or liable for the replacement of previously sold products with products or parts incorporating such changes.

SERVICE:

The equipment you have purchased has been carefully manufactured to provide dependable and satisfactory use. Like all mechanical products, it will require cleaning and maintenance. Lubricate the unit as specified. Observe all safety information in this manual and safety signs on the equipment.

For service, your authorized J&M dealer has trained mechanics, genuine J&M service parts, and the necessary tools and equipment to handle all your needs.

Use only genuine J&M service parts. Substitute parts may void warranty and may not meet standards required for safety and satisfactory operation. Record the model number and serial number of your equipment in the spaces provided:

Model No: 46155-STX2 **Serial No:** _____

Date of Purchase: _____

Purchased From: _____

Provide this information to your dealer to obtain correct repair parts.



Serial Number

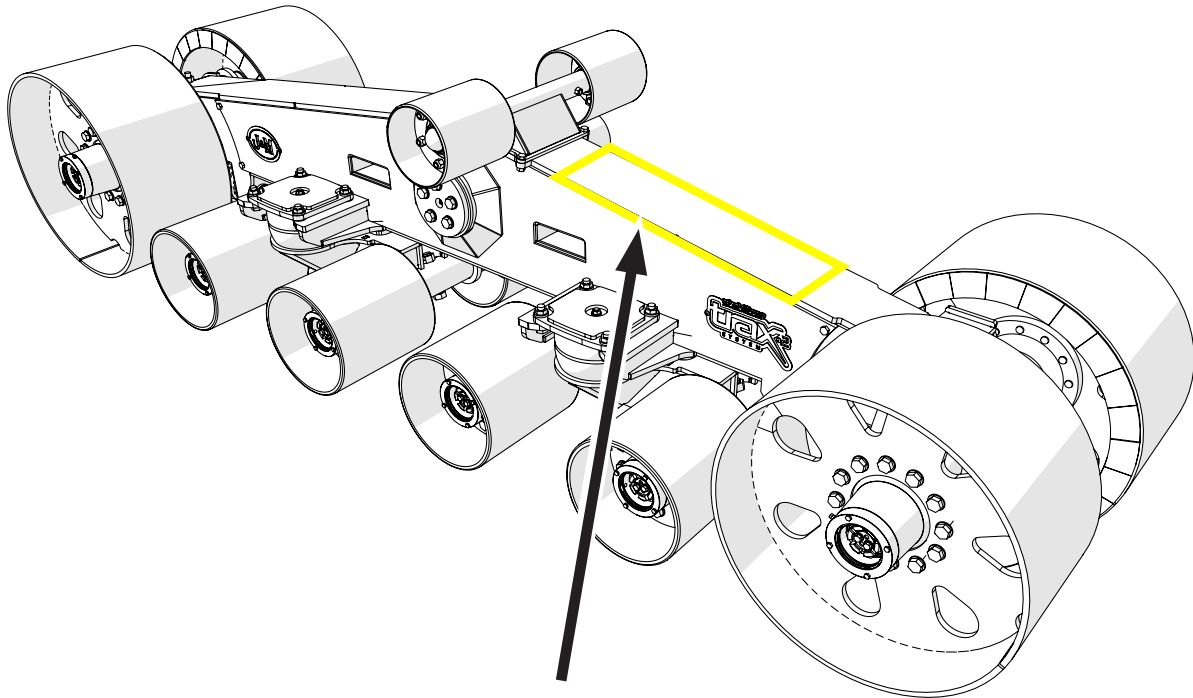

Serial Number Location

Serial Number: _____

Model Number: _____

Standard practice when ordering parts or obtaining information from your dealer requires the serial number and model number. Have numbers available before making contact.

General Information

TO THE OWNER:

The purpose of this manual is to assist you in operating and maintaining your Stabilizer Tracks in a safe manner. Read it carefully. It furnishes information and instructions that will help you achieve years of dependable performance and help maintain safe operating conditions. If this machine is used by an employee or is loaned or rented, make certain that the operator(s), prior to operating:

1. Is instructed in safe and proper use.
2. Reviews and understands the manual(s) pertaining to this machine.

Throughout this manual, the term **IMPORTANT** is used to indicate that failure to observe can cause damage to equipment. The terms **CAUTION**, **WARNING** and **DANGER** are used in conjunction with the Safety-Alert Symbol, (a triangle with an exclamation mark), to indicate the degree of hazard for items of personal safety. When you see this symbol, carefully read the message that follows and be alert to the possibility of personal injury or death.



This Safety-Alert symbol indicates a hazard and means **ATTENTION! BECOME ALERT! YOUR SAFETY IS INVOLVED!**



DANGER

Indicates an imminently hazardous situation that, if not avoided, will result in death or serious injury.



WARNING

Indicates a potentially hazardous situation that, if not avoided, could result in death or serious injury, and includes hazards that are exposed when guards are removed.



CAUTION

Indicates a potentially hazardous situation that, if not avoided, may result in minor or moderate injury.

IMPORTANT

Indicates that failure to observe can cause damage to equipment.

NOTE

Indicates helpful information.

Safety Rules

 **ATTENTION! BECOME ALERT! YOUR SAFETY IS INVOLVED!** 

Safety is a primary concern in the design and manufacture of our products. Unfortunately, our efforts to provide safe equipment can be erased by an operator's single careless act. In addition, hazard control and accident prevention are dependent upon the awareness, concern, judgment, and proper training of personnel involved in the operation, transport, maintenance and storage of equipment.

Make certain that the operator(s), prior to operating is instructed in safe and proper use and reviews and understands the manual(s) pertaining to this machine. Also make certain that the operator(s) reviews and understands the operator's manual of the grain cart and the tractor.

Read this manual before you operate this machine. If you do not understand any part of this manual, or need more information, contact the manufacturer or your authorized dealer.

 **SAFETY** 

Understand that your safety and the safety of other persons is measured by how you service and operate this machine.

The safety information given in this manual does not replace safety codes, federal, state or local laws. Make certain your machine has the proper equipment as designated by local laws and regulations.

A frequent cause of personal injury or death is from persons falling off equipment and being run over. Do not permit persons to ride on this machine.

Travel speeds should be such that complete control and machine stability is maintained at all times. Where possible, avoid operating near ditches, embankments and holes. Reduce speed when turning, crossing slopes and rough, slick or muddy surfaces. If a ditch must be crossed, do so at an angle. Avoid sharp turns to maximize the stability of the road. Reduce speed when turning, crossing slopes and rough, slick or muddy surfaces. Avoid running over hard objects protruding above the ground surface, if possible. Damage to the understructure or load may result. If the object is unavoidable, reduce speed.

Collision of high-speed road traffic and slow-moving machines can cause personal injury or death. Keep hands, feet, hair and clothing away from moving parts while unit is in operation. Make sure that everyone is clear of equipment before applying power or moving the machine.

Never adjust, service, clean, or lubricate track system until all power is shut off. Support equipment and attachments properly when working beneath them. Do not depend on hydraulic cylinders to hold them up. An attachment can fail if a control is moved, or if a hydraulic line breaks. Wear protective glasses when servicing equipment.

Specifications



Belt Width	46"
Overall Length	155.6"
Weight (One Track)	7,400 lbs
Footprint Dimensions (One Track)	46" x 121.4"
Footprint Area (Both Tracks)	11,170 in ²
Average Ground Pressure with 1,500 Bushel Cart	9.6 psi*
Center Pivot Spindle	7" Diameter

* Average ground pressure measured using 1,500 bushel grain cart.

Bolt Torque Chart

Always tighten hardware to these values unless a different torque or tightening procedure is listed for specific application. Fasteners must always be replaced with the same grade as specified in the manual parts list. Always use the proper tool for tightening hardware. Ensure fastener threads are clean and you start thread engagement properly. **Use these values when tightening all bolts and nuts with the exception of wheel nuts.**

SAE Fasteners

Coarse Thread Series				
Diameter and Pitch (Inches)	Grade 5		Grade 8	
	Dry	Oiled	Dry	Oiled
1/4"-20	8 ft-lbs	6 ft-lbs	12 ft-lbs	9 ft-lbs
5/16"-18	17	13	25	18
3/8"-16	31	23	44	33
7/16"-14	49	37	70	52
1/2"-13	75	57	106	80
9/16"-12	109	82	154	115
5/8"-11	150	113	212	159
3/4"-10	267	200	376	282
7/8"-9	429	322	606	455
1"-8	644	483	909	681
Fine Thread Series				
Diameter and Pitch (Inches)	Dry	Oiled	Dry	Oiled
1/4"-28	10 ft-lbs	7 ft-lbs	14 ft-lbs	10 ft-lbs
5/16"-24	19	15	27	20
3/8"-24	35	26	49	37
7/16"-20	55	41	78	58
1/2"-20	85	64	120	90
9/16"-18	121	91	171	128
5/8"-18	170	127	240	180
3/4"-16	297	223	420	315
7/8"-14	474	355	669	502

Stud and Wheel Nut Torque Specifications

Always tighten hardware to these values unless a different torque or tightening procedure is listed for specific application. Fasteners must always be replaced with the same grade as specified in the manual parts list. Always use the proper tool for tightening hardware. Ensure fastener threads are clean and you start thread engagement properly. **Use these values when tightening all studs and wheel nuts.**

Tightening End Wheel Bolts: Standard **3/4"-10** bolts should be tightened to torque **400 ft-lbs** during initial operation of the tracks and then checked for proper torque after every 10 hours of use. Failure to do so may damage wheel nut seats. Once seats are damaged, it will become impossible to keep nuts tight.

Tightening Upper Roller Nuts: Standard **1/2"-20** wheel studs and nuts should be tightened to torque **120 ft-lbs**.

RECOMMENDED TIP: Use a paint stick to mark the location of each bolt prior to use. Mark on the wheel and lugnut. This provides a quick and accurate visual check for lug tightness.

Tight

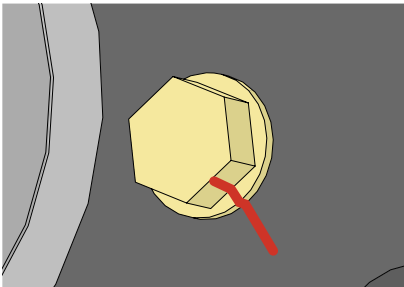

Loose

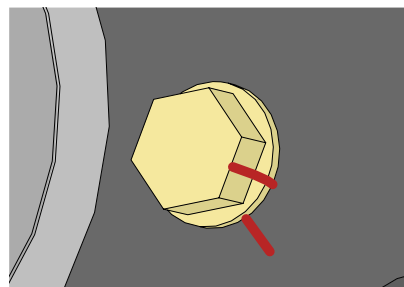

Castle Nut Torque Setting

Torque all idler and bogie wheel Stabilizer track model hubs at 70 ft-lb. Apply 250 ft-lb of torque to the castle nut while rotating the hub to ensure that the hub components are properly seated. Then loosen the castle nut one full turn. After that, apply the recommended torque (70 ft-lb) to the castle nut. Spin the hub several revolutions and re-apply the recommended torque. Continue spinning the hub and re-applying the torque until the castle nut no longer spins at the recommended torque. Install the castle nut retainer using two 3/8"-16 x 5/8" Gr5 Z SF Hex Bolts, locking the castle nut in place.

Note: The castle nut retainer has four holes and the spindle has two threaded holes for it to go into. You may need to flip the castle nut retainer in order to line up the holes of the plate to the spindle. If you cannot find a way to line up the holes, rotate the castle nut counterclockwise (slightly looser) while keeping the castle nut as close to the correct torque settings as possible.

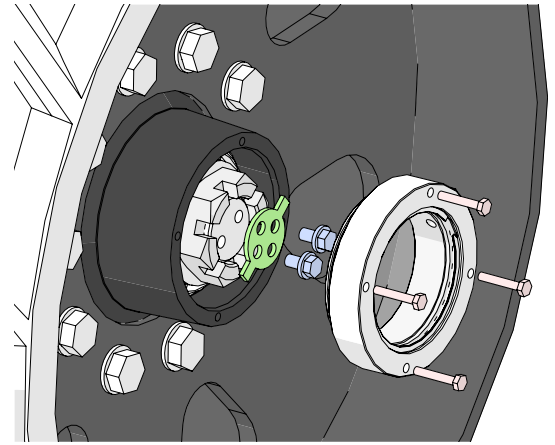

Lubrication Schedule

Check the oil level in the hubs by looking through the dust cap sight glasses. The oil level should be maintained between the top of the 2" diameter threaded portion of the spindle and bottom of the castle-nut washer (as pictured below). If the oil is below the castle-nut washer, add a GL-5 SAE 75W-90 synthetic gear oil with rust and oxidation inhibitors. Change the oil in the hubs annually. When changing the oil after the first year, recheck the castle nut tightness. The hub components can loosen after initial break in period. Retightening the castle nut will prevent too much endplay in subsequent years; they do not tend to loosen after retightening. If bearing components are ever replaced the castle nut should be retightened the following year. If the old oil is observed to still be in good operating condition (clean and unstained) after successive oil changes, the frequency of oil changes may be reduced to bi-annually at the owner's discretion. When changing oil, add 22 oz of oil for the end idler wheels, and 16 oz of oil for the bogie wheels.

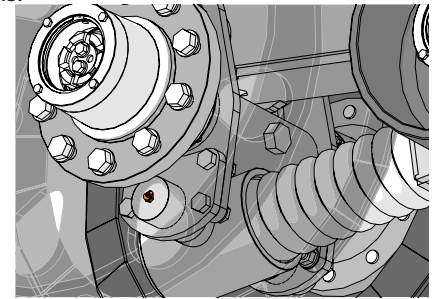
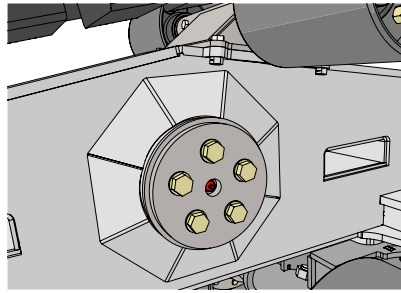
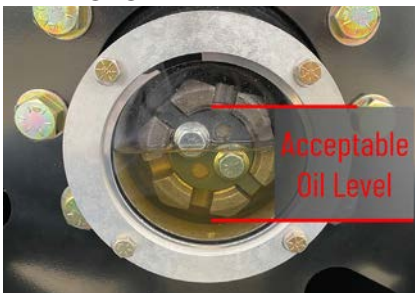

Track sleeve bushing locations are highlighted in green, yellow, and red in the image below. All sleeve bushing liners are constructed of self-lubricating materials, so they do not require grease. Grease, however, has been found to reduce self-lubricated sleeve bushing wear by up to 8x in some instances. Because of this, grease zerks are provided for the pivot locations highlighted in yellow and red. The pivot locations highlighted in yellow and green are greased initially at the factory during assembly. Pivot locations highlighted in green require no grease and will need replaced over time. For general replacement guidelines, see the table located under "Sleeve Bushing Wear/Replacement" on page 15. It is recommended that the dealership grease the pivot locations highlighted in red before delivery. It is also recommended that **all yellow and red pivot locations be greased again annually before use** to purge old grease from the pivot cavities. This will help to maximize self-lubricated sleeve bushing life. More frequent greasing is acceptable.

The upper midrollers, shown in the blue box in the image to the right, should be checked annually for free rotation and quiet, smooth operation. Do so by lifting the belt near the upper midrollers slightly above them so that the belt is no longer contacting the rollers. If an upper midroller does not spin freely, smoothly, and quietly, remove the upper midroller and re-pack the upper midroller hub bearings with grease. It is estimated that the upper midroller bearings may need re-packed every 2-6 years, depending on operating conditions.

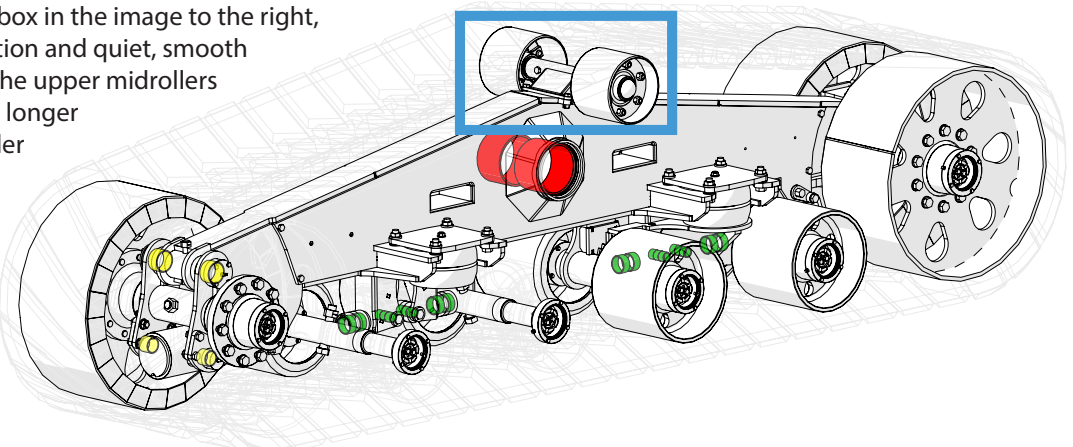

Routine Maintenance

FIRST 40 HOURS

Check ALL wheel bolts/nuts for correct torque setting (400 ft-lb for 3/4"-10 wheel bolts). Tighten as needed. Re-check wheel bolt/nut torque settings during initial break-in period (during 1st, 2nd, 3rd loads, etc.), then periodically afterwards (every 10 hours of use). Keep checking wheel bolt/nut settings until wheel bolts/nuts do not loosen. Failure to keep the wheel bolts/nuts tight could cause considerable damage to the grain cart and surroundings. Damage caused by failure to keep the wheel bolts/nuts tight is not warrantable. Inspect the belt for any defects. If any defects are found, contact the J&M Service Department.

DAILY

Remove debris buildup from the surface of idler wheels and upper midrollers. Debris buildup on the surface of idler wheels and upper midrollers can temporarily alter the belt alignment and cause guide lug wear. Debris buildup on the surface of idler wheels and upper midrollers can also cause the belt to become overly tensioned, leading to damage to the tensioner system as well as to the idler wheel and upper midroller assemblies. Damage done to the track system as a result of debris build-up is not covered under warranty. (Debris buildup on the bogie wheels is less problematic than on the idler wheels and upper midrollers, but should be removed periodically as well.) Debris buildup should also be removed as needed from the remainder of the track undercarriage so that adequate routine maintenance inspections can be performed.

Inspect guide lugs for signs of uneven and/or increased wear. If uneven and/or increased wear is observed, check belt alignment according to "Alignment" on page 11.

Inspect the oil level in the idler and bogie hubs. See the "Lubrication Schedule" on page 9 for more details.

TENSIONER

A single, large-diameter compression spring provides active tension for the track belt. The spring tensioner requires no adjustment during operation. If tension on a track differs considerably from side to side, check belt alignment.

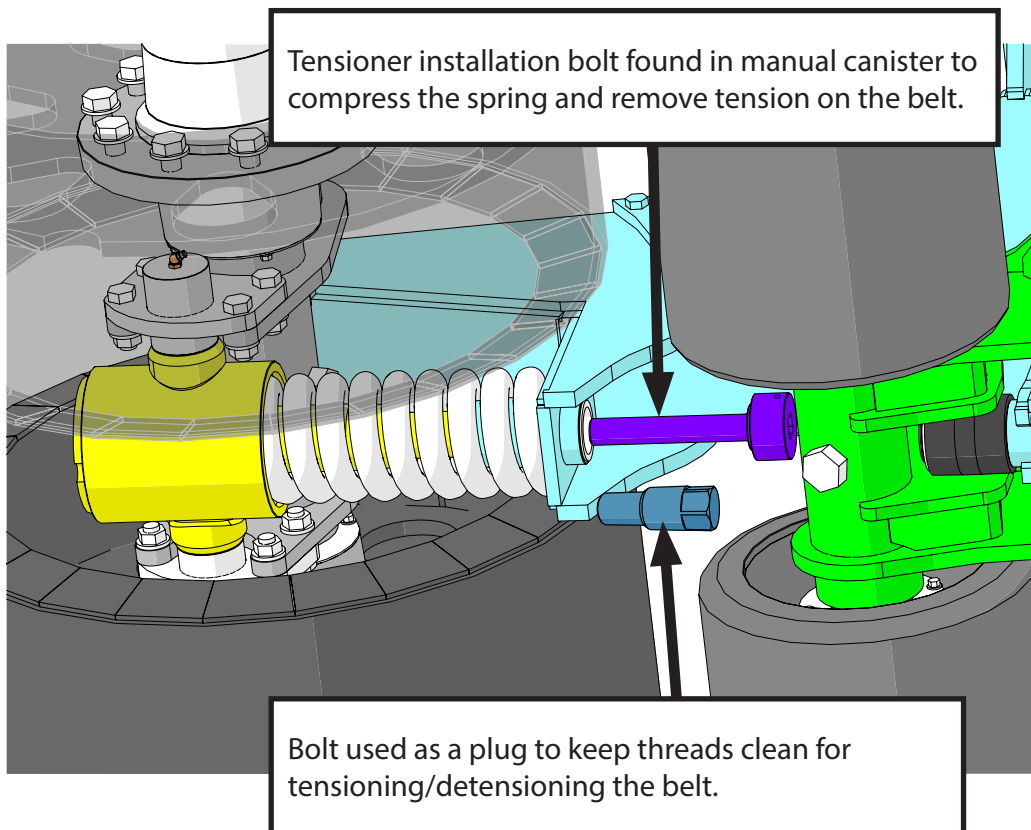

Alignment

The track belts are held in proper alignment by the Swivel Alignment Weldments. Track alignment is set at the factory but may need further adjustment during the initial belt break-in period, and sometimes occasionally throughout the life of the belt. During the break-in period, the track belt loses its initial tackiness, and the track rolling components undergo a polishing process to achieve a smoother steel-to-rubber interface with the guide lugs. Track alignment should be monitored closely and may need adjusted more frequently during the break-in period. If the cart is towed to/by the customer from the dealership, the alignment needs to be checked within the first mile of towing. Towing speeds should NOT exceed 25 mph. It is highly recommended to add several cups of talc to the inside of the belt over the guide lugs before and during initial towing to help lubricate the guide lugs, remove the initial tackiness of the belt, and reduce guide lug wear during the break-in process. If the towing/transport duration exceeds 30 minutes, a 15-minute cool down period is recommended before resuming towing/transport.

To determine if track alignment needs adjusted, pull the tracks 500-1,000 ft in a straight line on level terrain. Then measure the temperature on each side of the guide lugs. If the temperature of one side is significantly higher (10-20°F or more) than the other, adjust the alignment by following the instructions below. Repeat the process, allowing the guide lugs to cool in between adjustments, until there is no longer a significant temperature difference between sides of the guide lugs. (Note that all nuts and bolts for the alignment adjustment require 15/16" sockets/wrenches. An impact wrench is recommended for tightening the Alignment Bolts.)

- Step 1: Loosen the Hex Nut from the Hex Bolt on each Alignment Bolt Keeper. Remove the Hex Nut, Hex Bolt, and Alignment Bolt Keeper from each Alignment Bolt.
- Step 2: Adjust the track alignment by moving the Alignment Adjustment Plate of the Swivel Alignment Weldment with the Alignment Bolts. Turn the Alignment Bolts 1 turn in the direction that moves the Alignment Adjustment Plate towards the heated side of the Guide Lugs. Do so by first loosening one Alignment Bolt and then tightening the opposite Alignment Bolt against the Alignment Adjustment Plate until the Alignment Adjustment plate is tight against both Alignment Bolts. If the Alignment Bolts have been turned 6 turns from center (one Alignment Bolt extends beyond the UC Beam by 1-5/8") and the track is still not aligned, contact the J&M Service Department.
- Step 3: Reinstall the Alignment Bolt Keeper, Hex Bolt, and Hex Nut for each Alignment Bolt. If the Alignment Bolt extends beyond the UC Beam by more than 1-1/8", flip the Alignment Bolt Keeper before fastening it so that the Annulus of the Alignment Bolt Keeper is touching the UC Beam.

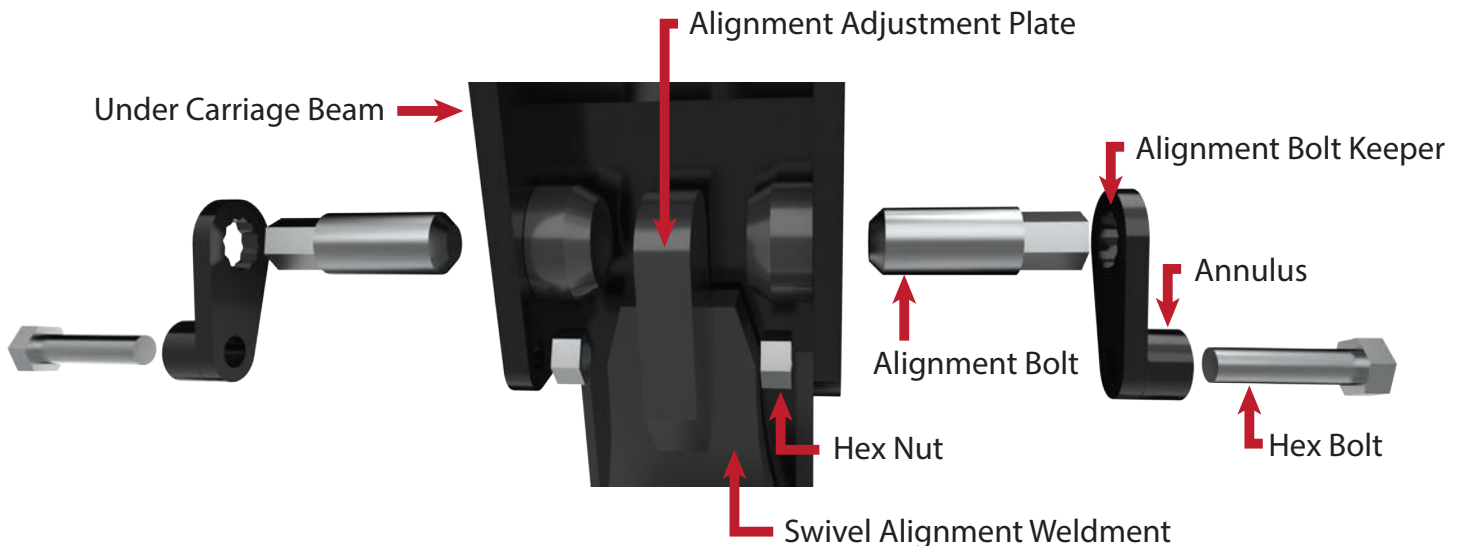
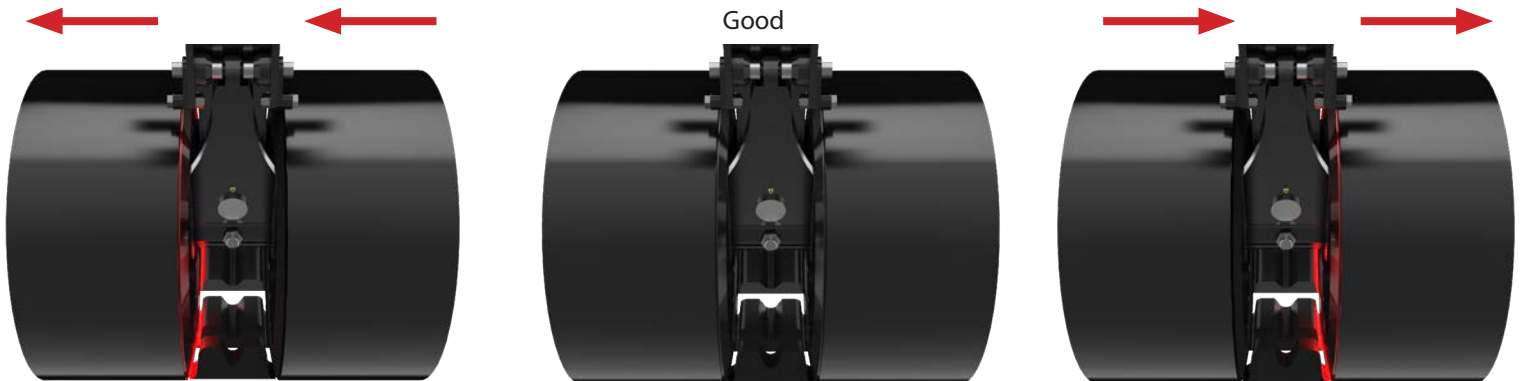

Service

When performing maintenance work, wear sturdy, rough-soled work shoes and protective equipment for eyes, hair, hands, hearing and head. Follow the instructions in this Operator's Manual to ensure safe and proper maintenance and repair.

Your local, authorized dealer can supply genuine replacement parts. Substitute parts may not meet original equipment specifications and may be dangerous.

NOTE: BE CERTAIN THAT ALL POWER IS SHUT OFF TO THE GRAIN CART BEFORE PERFORMING ANY MAINTENANCE OR REPAIR WORK.

BELT INSPECTION

The rubber track contains several layers of cables. These layers include a tension cable layer, reinforcement plies, and alignment plies. The orientation of the cables varies for each layer.

When any of the cables are exposed to moisture by cuts or gouges in the rubber, they can deteriorate by rusting. Because of this, any exposed cables should be repaired as soon as possible. Any damaged cables that protrude above the surface of the track should be clipped or ground down to below the surface of the track to prevent additional damage due to unraveling.

Cuts, gouges and minor wear on guide lugs are not expected to cause operational problems. However, a track that has two or more consecutive guide lugs missing should be replaced since this could lead to untracking, possibly damaging other undercarriage components.

ROTATE TRACKS

If one track belt becomes more worn than the other due to certain operating conditions (e.g., side hill operation or frequent travel on crowned roads), rotating the track assemblies from one side of the cart to the other may increase the service life of the tracks.

DETENSIONING/TENSIONING THE TRACK BELT

Prior to performing certain maintenance tasks, detensioning the track belt is required. The procedures for detensioning/tensioning the track belt are outlined on the following pages.

Detensioning the Track Belt

1. Using a fork lift, drive forks underneath the track belt on each side of the upper midrollers. Lift up on the belt until just before the track beneath the bogie wheels becomes lifted above the ground. (Note: The track can be detensioned without this step, but doing so lessens the effort required during the remainder of the detensioning process.)

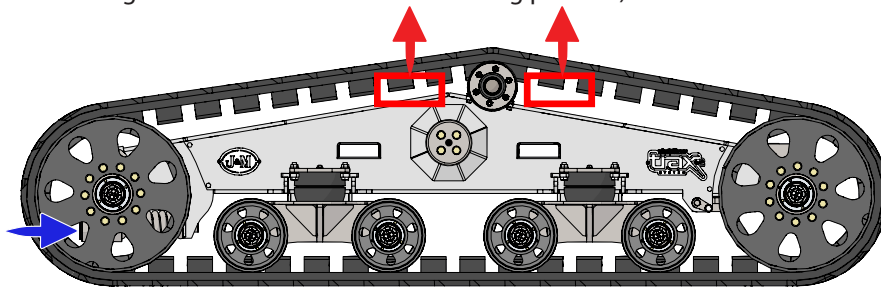

2. Remove the tensioner plunger nut plug with a 1-1/8" socket and a 3/4" square drive ratchet wrench.

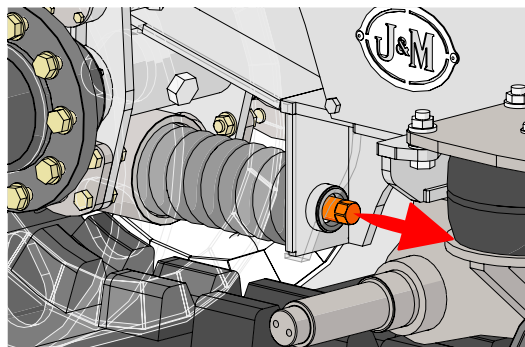

Service

3. Install the tensioner installation bolt found in the manual canister to further compress the spring and detension the belt. **Grease the threads and contacting face of the tensioner installation bolt prior to installation.** Tighten the bolt with a 3/4" square drive ratchet wrench until the spring is adequately compressed for the maintenance task being performed. When fully tightened, the distance shown below will measure approximately 8-1/4"-8-1/2". The maximum tightening torque on the bolt will be approximately 200 ± 40 ft-lb. **Do NOT overtighten the tensioner installation bolt.**

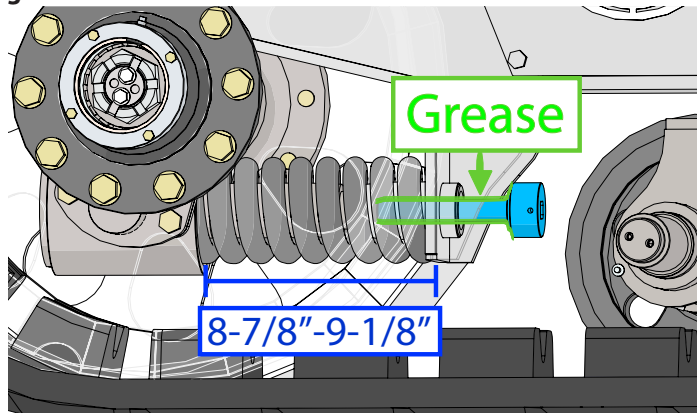

Grease entire length of detensioner bolt as well as the contacting face of the bolt to lessen installation torque.

4. For maximum slack in the belt, remove the upper midrollers and bracket from the top of the UC beam.

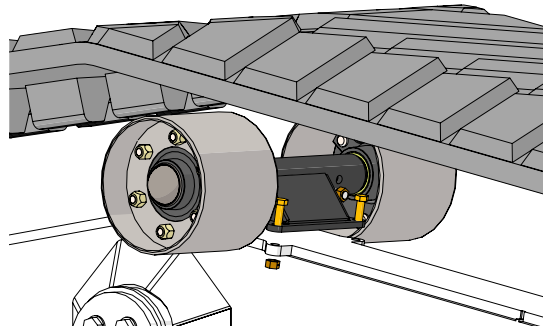

5. Lower the track belt and remove the fork lift forks. The track belt is now detensioned.

Detensioning the Tensioner Weldment

NOTE: The following steps are only needed if maintenance is needed on the tensioner weldment, tensioner lower side plate weldment, or tensioner spring pivot weldment.

1. After the track belt has been removed, loosen the tensioner installation bolt until the distance from the face of the spring pivot weldment spool to the UC beam spring plate is 11-5/8" - 12". The tensioner spring pivot weldment should have a small gap between it and the idler spindle spool.

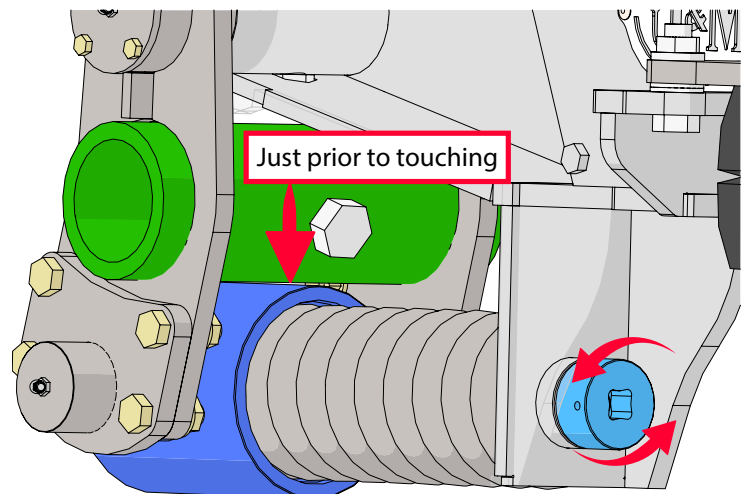
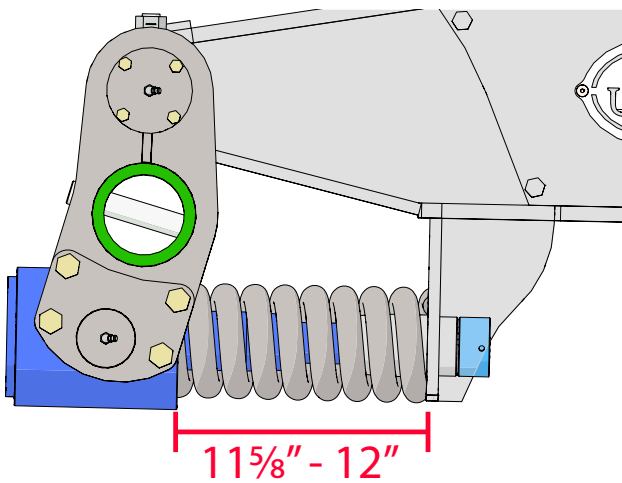

Service

2. Remove all but the lower rear installation bolt from the tensioner lower side plate weldments. Loosen the nut on the remaining bolt. This will allow the spring to be completely released without bending the installation bolt.

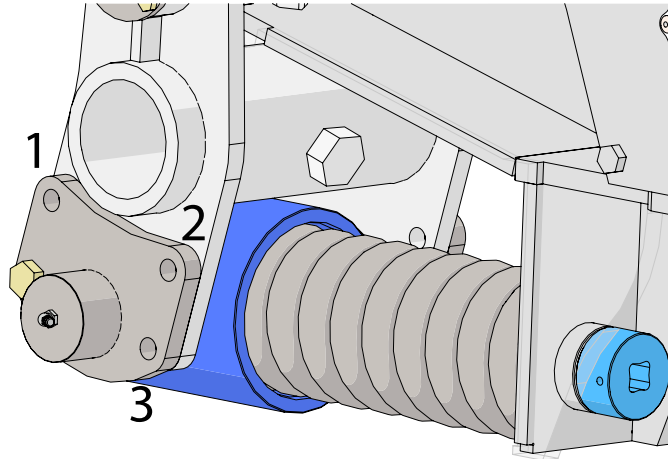

3. Finish loosening and remove the installation bolt. The spring is now detensioned.

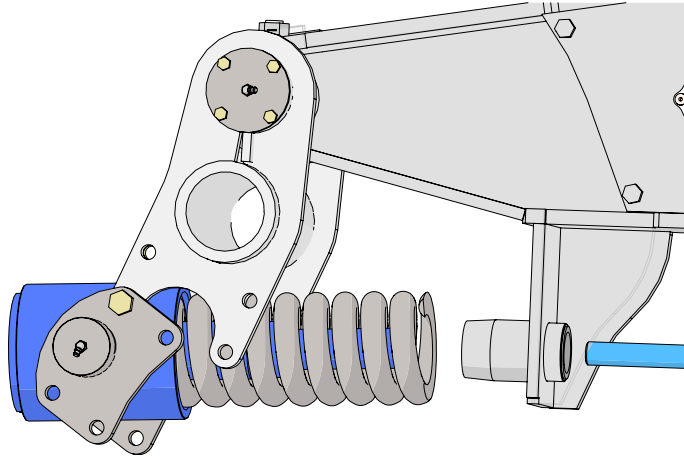

Tensioning the Tensioner Weldment

1. Swing the spring retention weldment back into place and insert the installation bolt.
2. Tighten until you can easily replace the three bolts in the lower side plate weldments and tighten all bolts.
3. Tighten the installation bolt with a 3/4" square drive ratchet wrench until fully tightened. The distance shown in the image on step three of "Detensioning/Tensioning the Track Belt" on page 12 will measure approximately 8 7/8"-9 1/8". The maximum tightening torque on the bolt will be approximately 215 ± 40 ft-lb. **Do NOT overtighten the tensioner installation bolt.**

Tensioning the Track Belt

1. Make sure the belt is in place and the upper midrollers installed (if they were removed). Using a fork lift, drive forks underneath the track belt on each side of the upper midrollers. Lift up on the belt until just before the track beneath the bogie wheels becomes lifted above the ground.
2. Remove the installation bolt with a 3/4" square drive ratchet wrench.
3. Install the tensioner plunger nut plug with a 1-1/8" socket and a 3/4" square drive ratchet wrench.

SLEEVE BUSHING WEAR/REPLACEMENT

The sleeve bushings on the track system wear slowly with use and need replaced over time to maintain optimal track performance and to prevent damage to surrounding track surfaces/components. The rate at which sleeve bushings wear depends on a variety of operational and environmental factors. Estimated replacement intervals for each of the track sleeve bushings are shown below. Spool misalignment, internal slop and noise coming from pivot locations are indications that bushing replacement may be needed. For bushing installation tools, call J&M.

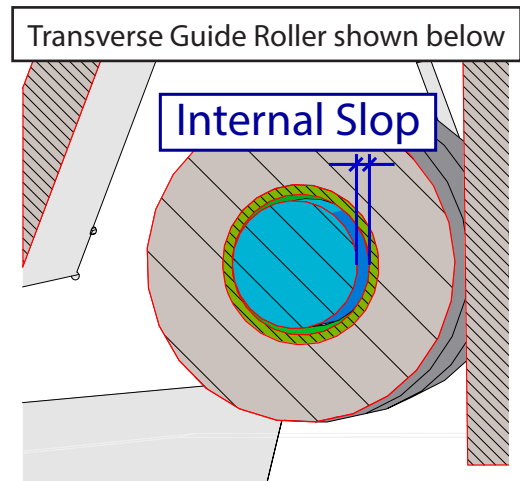
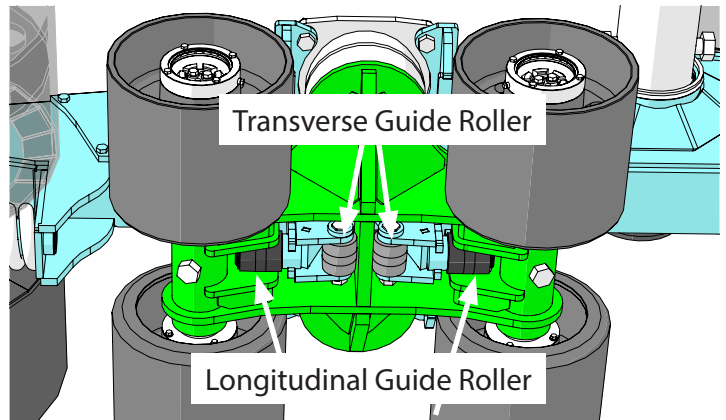
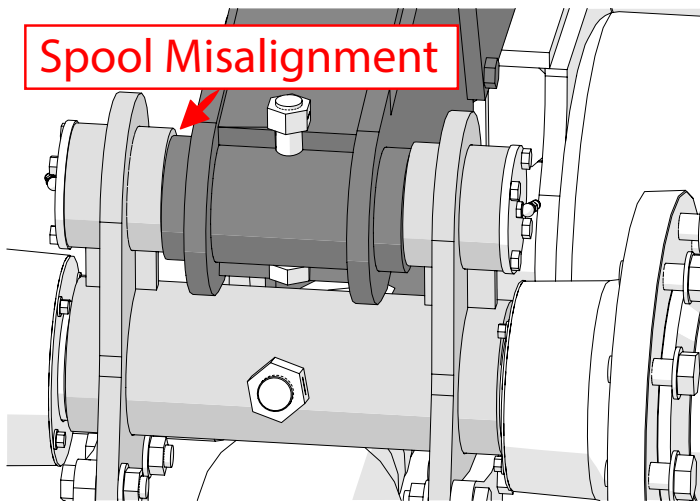

Location	Size	Estimated Replacement Interval (Ac)	Replacement Notes
Tensioner Weldment	3" ID x 3-1/4" OD x 1-1/2" Long	30,000	Replacement is necessary when UC beam spool and tensioner spools become misaligned by 1/32" - 1/16". See images above.
Tensioner Lower Side Plate Weldment	1-3/4" ID x 2" OD x 1-1/2" Long	30,000	Replace when replacing tensioner weldment bushings.
UC Beam - Tensioner Slide Spool	1-3/4" ID x 2" OD x 2" Long	30,000	Replace when replacing tensioner weldment bushings.
UC Beam - Tensioner Slide Spool	45mm ID x 50mm OD x 50mm Long	30,000	Replace when replacing tensioner weldment bushings.
Longitudinal Guide Roller	2-1/2" ID x 2-3/4" OD x 1-1/2" Long	15,000	Replace roller if > 1/16" internal slop. Replace roller if OD < 3-3/8". Replace roller if any flat spots are present.
Transverse Guide Roller	1" ID x 1-1/4" OD x 7/8" Long	15,000	Replace roller if > 3/16" internal slop. Replace roller if OD < 2-3/8". Replace roller if any flat spots are present.
UC Beam - Center Pivot	7" ID x 7-1/2" OD x 4" Long	15,000	Slide track off spindle to examine. Replace bushing when teflon liner is worn down to fiberglass backing. (Replace when bushing ID > 7.08")

TENSIONER SPRING REPLACEMENT

As a precautionary measure, it is recommended that the tensioner spring be replaced whenever the tensioner weldment sleeve bushings are replaced.



HOW TO FLUSH THE OLD OIL OUT OF THE OIL BATH HUBS

1. Drain the hub by removing the cap. There is no need to tilt the track, the oil will flow through the bearing easily. A screwdriver may be needed to help pry the cap away from the hub.
2. Replace the cap once the oil is finished draining.

HOW TO ADD OIL TO OIL BATH HUBS

1. Roll the hub until the fill plug is on top.
2. Remove the fill plug.
3. Use an oiler hand pump to add a GL-5 SAE 75W-90 synthetic gear oil with rust and oxidation inhibitors. When empty, it takes **16 oz of oil** for bogies and **22 oz of oil** for the end idlers to fill to the recommended level.
4. Replace the fill plug. Use PTFE tape on the fill plug threads for a tight seal.

STORAGE PREPARATION

IMPORTANT: When the track system is not going to be used for a length of time, thoroughly clean the tracks, removing all dirt/debris from the track system. Store the tracks in a dry, protected place. Leaving your track system outside, open to the weather, will shorten its life. Park the track system on level ground. Block the front and rear of the belts to prevent the tracks from rolling unexpectedly. Inspect the track system and touch-up spots where the paint has been worn away (use a good quality primer paint).

To maximize the life of the rubber springs, do not store grain in the cart when the cart is in storage.

REMOVING FROM STORAGE

1. Inspect rubber belt for cuts or gouges and repair any damaged cables.
2. Check the belt for missing or damaged guide lugs and replace as necessary.
3. Check the track system for cracks in welds and for other structural damage. Have cracked welds/structural damage fixed prior to operation.
4. Check belt alignment.
5. Check the oil level in each idler/bogie hub. If the oil level in a hub is low, inspect the front and rear of the hub for potential leaks. Repair/replace dust caps and/or seals as needed on leaking hubs to remove the leak.
6. Inspect upper midrollers for free rotation (when not in contact with the track belt) and quiet, smooth operation. Re-pack or replace hub bearings as needed.
7. Check the wheel bolts/nuts and make sure they are properly torqued.
8. Inspect all track pivot/slide locations (shown in "Lubrication Schedule" on page 9) for excessive bushing wear.
9. Inspect longitudinal and transverse guide rollers for exterior roller wear. The following measurements indicate that the rollers should be replaced:
 - a. Longitudinal guide roller OD < 3-3/8"
 - b. Transverse guide roller OD < 2-3/8"
10. Check the distance between the bottom of the track bogie wheels and the bottom of the track idler wheels on a flat, hard surface with the grain cart empty. If the bogie wheels are ≤ 2 " below the idler wheels, the rubber spring suspension system may need adjusted. Contact the J&M Service Department if adjustment appears needed.

Installation

Step 1 - Install both spindles. Use (2) 1"-8 x 14" Gr8 YZ Hex Bolts and (2) 1"-8 Gr2 Z Centerlock Hex Nuts to attach the spindles to the axle.

Step 2 - Use an overhead hoist to pick up the grain cart. Use a hoist and chains that are rated for the specific weights. The weights are located in the grain cart operator's manual. When raising the grain cart, keep the axle level with the ground.

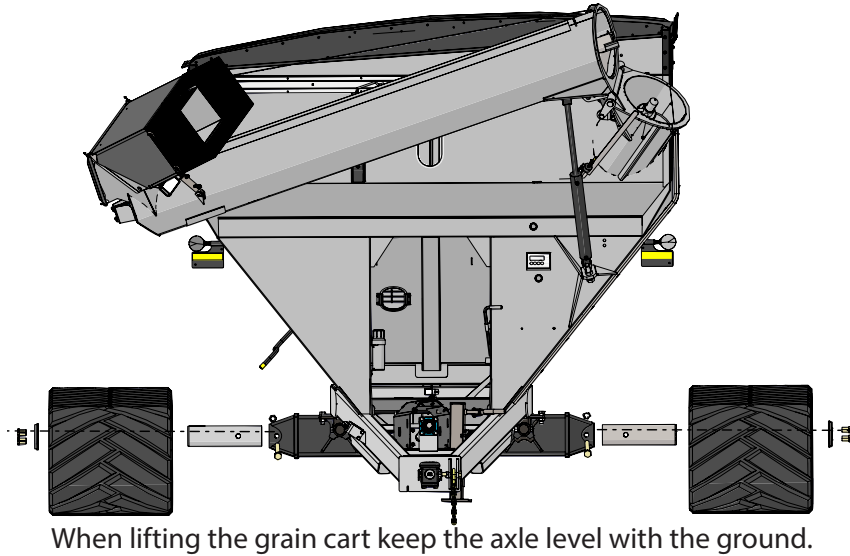

Step 3 - Pick the tracks up with a forklift. Put both of the forks in the slots on the tracks designed for the forks. It is recommended to use a forklift with the side shift option available. Use a forklift that is rated for at least 7,000 lbs for the tracks.

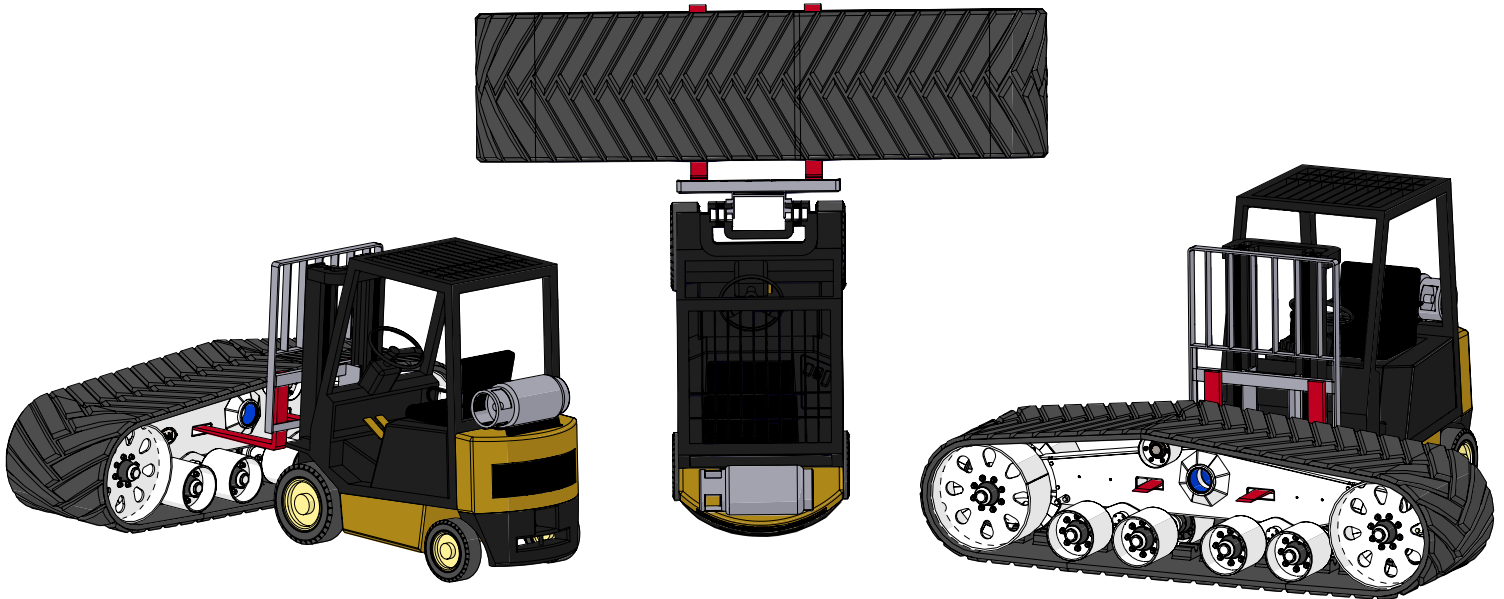

Step 4 - Slide the tracks onto the spindle. Be sure to center the track bushings with the spindle prior to attempting to slide the track on so that no damage is done to the bushing's liner or the 7" ID x 7-3/4" OD Rod Wiper. Grease both the bushing liner and the spindle prior to assembly.

Step 5 - Install the Center Pivot Spindle Retainer Weldment. Use (5) 3/4"-10 x 2" Gr8 YZ Hex Bolts to fasten the Center Pivot Spindle Retainer Weldment to the spindle.

Step 6 - Tighten all of the hardware according to the "Bolt Torque Chart" on page 8.

Operation Guidelines

The track system offers benefits which can be maximized by following recommended operational practices. In reviewing these guidelines, you will learn the best ways to gain these benefits.

The four basic rules for maximizing track life are:

1. **Follow track break-in procedures**
2. **Verify and maintain alignment**
3. **Understand ways to maximize tread life**
4. **Use correct operational techniques**

By understanding these rules, you learn operational techniques and methods which help achieve years of trouble-free service.

1. TRACK BREAK-IN

Before any road transport is done, especially when new, expose the inside of the tracks to soil, or a dry lubricant. Keep speeds down when breaking in new tracks.

Guide lug life benefits from correct break-in procedures. Correct break-in reduces initial guide lug wear. During the break-in period, rolling components undergo a polishing process to achieve a smooth steel-to-rubber interface with the guide lug. Rubber surfaces use dust and dirt as a dry lubricant during break-in to minimize heat and reduce rubber stickiness. New tracks lacking a coating of dust should be exposed to dry and dusty soil conditions as soon as possible. Do not road transport a new track system without first exposing the inside of the track to soil, dirt, or other dry lubricant. Road transport of new rubber without dry lubricant may generate damaging heat and can cause guide lug damage/wear. If roading must be done, then a dry lubricant such as soil, talc, or floor-dry should be applied to the guide lugs periodically during roading until exposure to the field commences.

2. TRACK ALIGNMENT

Monitor track alignment and recheck periodically.

Track alignment is the most important periodic check that can be made on a track system. ALWAYS check alignment very carefully before road transport is done. Alignment can change due to component wear, track damage, end wheel buildup, operation on sloped surfaces, or following track replacement. Misalignment causes wear to guide lugs, so periodic alignment checks are important. By checking if there is significant difference in surface temperatures or wear between the inner and outer guide lug faces, you can determine if the track is in proper alignment. See "Alignment" on page 11.

Note: *Minimizing guide lug inner/outer temperature difference is the best way to achieve correct alignment.*

3. MAXIMIZE TREAD LIFE

Use care during road transport. DO NOT TRANSPORT A FULL LOAD ON THE ROAD.

Avoid conditions that cause high tread wear rates.

Several operational factors influence tread wear:

- Amount of roading (roading increases wear)
- Field soil conditions (abrasive increases wear)
- Operating weight and distribution
- Operator techniques

Tread life decreases with higher percentages of roading. Tread wear rates can be minimized by staying off pavement, and reducing transport weight and speed. The greatest rate of tread wear occurs on a hot day with a poorly balanced or heavily, loaded system. Always transport during cooler parts of the day and at reduced travel speeds and weight, as this will lower temperatures of the treads, guide lugs, and rolling components. Remember that frequent sharp turning of the track system (i.e. skidding around a tight turn) especially if done on hard surfaces and fully loaded, dramatically increases tread wear and puts high stresses on the mechanical components. Take wide turns whenever possible. 46" STX tracks are rated up to 25 mph. J&M recommends towing an empty grain cart at no faster than 20 mph and a loaded grain cart should not travel faster than 8 mph. **Speed in excess of these limits may lead to excessive belt and/or seal wear. Damage incurred in this manner is not warrantable.**

Do not transport a loaded grain cart outside the field. Transporting a loaded grain cart on a hard surface or road can lead to excessive heat buildup in the treads and cause permanent damage. Damage incurred in this manner is not warrantable.

Refer to your grain cart operator's manual to understand the maximum speed and duration limitations, as well as the maximum load limitations, while transporting your equipment. Always respect these limits.



Operation Guidelines

4. OPERATIONAL TECHNIQUES

Use recommended practices from J&M to improve track performance.

- Maintain correct track tension. For instructions on adjusting track tension, see “Routine Maintenance” on page 10.
- Proper tension is important for best track performance. Tension can change during service. Improper tension can increase the potential for derailing or untracking, or reduce the life of bearings and rolling components.
- Keep material out of the undercarriage. A track system will allow some material to ingest and pass through it, but sharp noncompressible objects cause high localized loads to both track and wheels, which if severe enough, can result in track and wheel damage. Inspect and clean material from the undercarriage before starting work.

Crossing ditches or diagonal transitions

During transitions from sloped to flat areas (or vice versa), the front and rear of the track may be in contact with the ground while the mid-section is unsupported. If turning is attempted at this time, the risk is higher for derailing or misalignment to occur.

Limit sharp turns

When pulling grain carts with a track system, avoid sharp turns or pivots. Sharp turns cause one or both tracks to slide across the surface resulting in berming, road surface damage, and excessive tread wear. To maximize the life of your track system, it is recommended that wide turns be consistently made whenever possible. Turning in a circle that is **THREE TIMES** the overall length of the tractor and track unit will reduce premature wear on the belt and undercarriage.

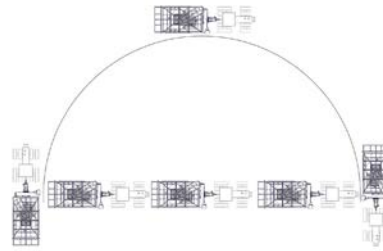
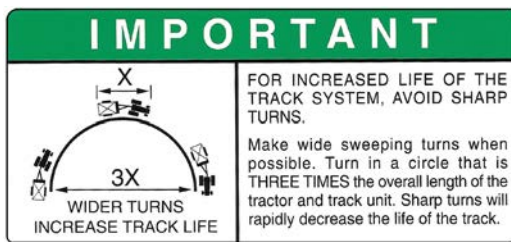

Repair Parts List and Diagrams

When performing maintenance work, wear sturdy, rough-soled work shoes and protective equipment for eyes, hair, hands, hearing and head. Follow the Operator’s Manual instructions to ensure safe and proper maintenance and repair.

Your local, authorized dealer can supply genuine replacement parts. Substitute parts may not meet original equipment specifications and may be dangerous.

⚠ WARNING

MAKE SURE ALL POWER IS SHUT OFF BEFORE PERFORMING ANY MAINTENANCE OR REPAIR WORK.

Decals

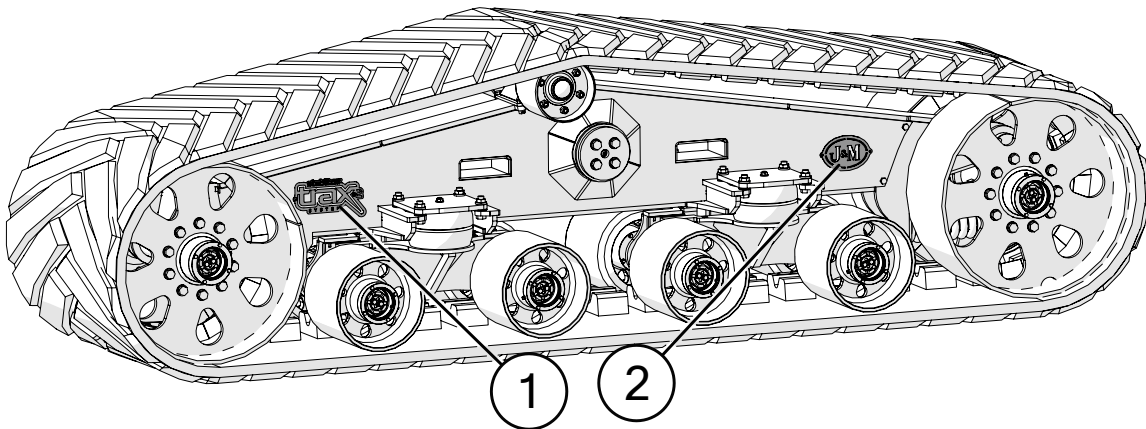

	Description	Part No.
1	STX2 Logo Stainless Steel Cutout with Rivets	JM0061328
2	J&M Stainless Steel Cutout Logo with Rivets	JM0050640



Track Beam Connections and Wheels

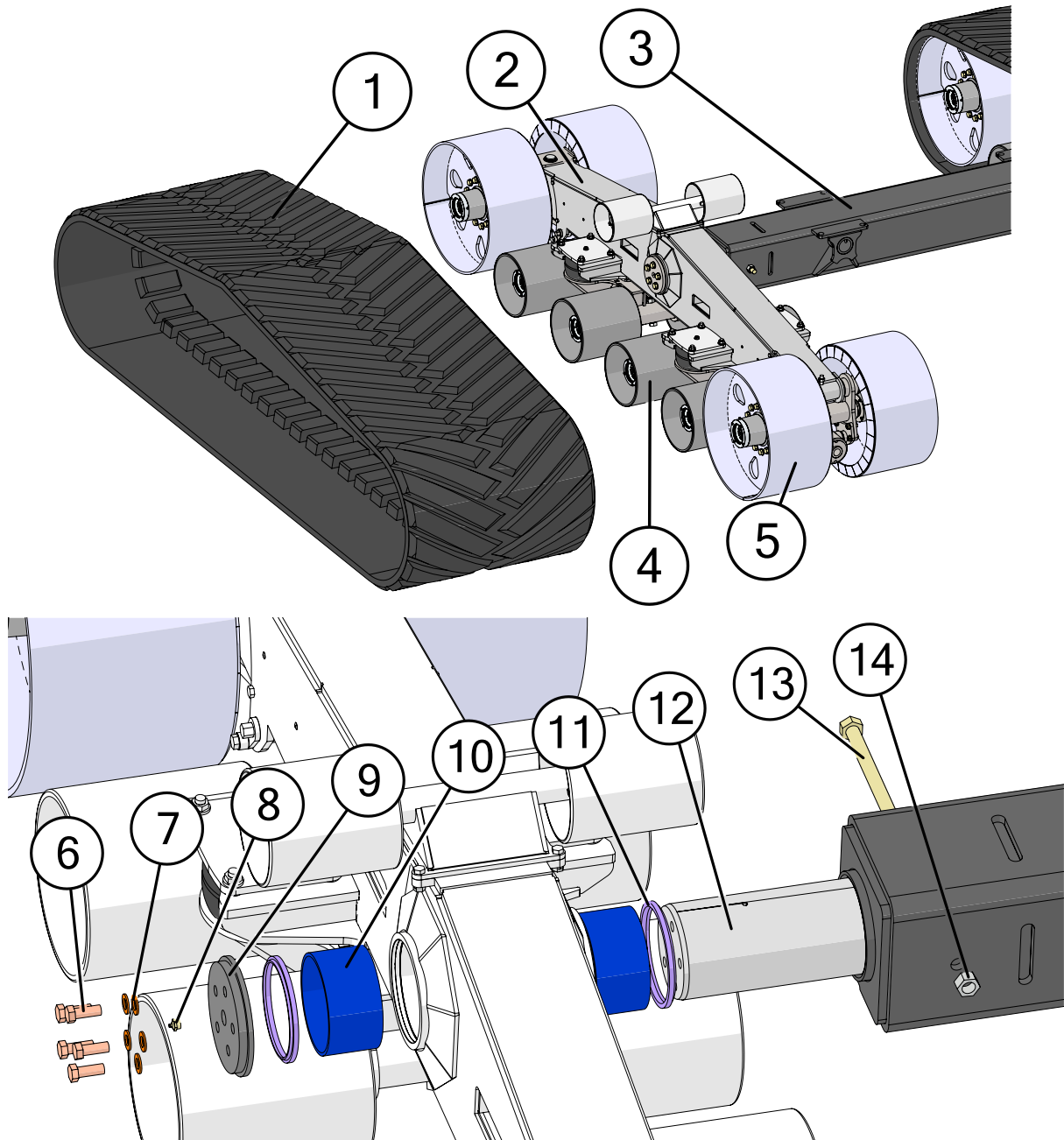

Parts below are for carts with 1700 bushel capacity and above.

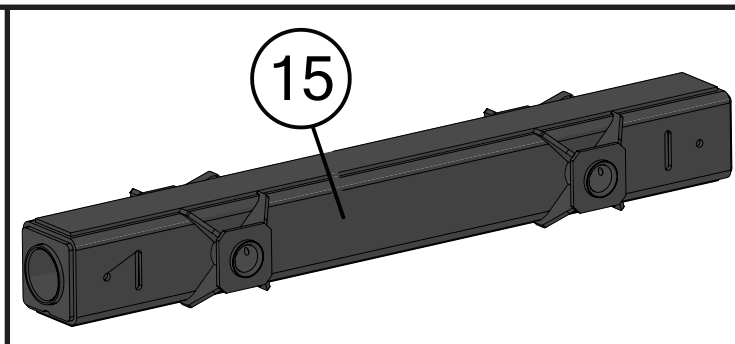

Track Beam Connections and Wheels

	Description	Part No.
1	46" x 336" Track Belt (STX)	JM0041343
2	46" STX2 - UC Beam Weldment	JM0075622
3	46155-STX2-278 - Axle Weldment	JM0076499
4	46" STX2 - Bogie Wheel Weldment 10 Bolt Hole	JM0075737
5	46" STX2 - Idler Wheel Weldment 12 Bolt Holes	JM0074305
6	3/4"-10 x 2" Gr8 YZ Hex Bolt	JM0041923
7	3/4" Hardened YZ SAE Flat Washer	JM0042264
8	3/8" NPT Male x 51/64" Straight Grease Fitting	JM0051112
9	Spindle Retainer Weldment for Tracks with 7" Spindle (5 Bolt Pattern)	JM0075885
10	7" ID x 7-1/2" OD x 4" Self-Lubricated Bushing	JM0041919
11	7" ID x 7-3/4" OD Rod Wiper	JM0075672
12	7" x 26" Center Pivot Spindle for Tracks	JM0075883
13	1"-8 x 14" Gr8 YZ Hex Bolt	JM0076416
14	1"-8 Gr2 Z Centerlock Hex Nut	JM0002149
15	Track Axle Weldment 108-3/4" Length (7" Spindle)	JM0074489

End Idler Hub and Spindle Assembly

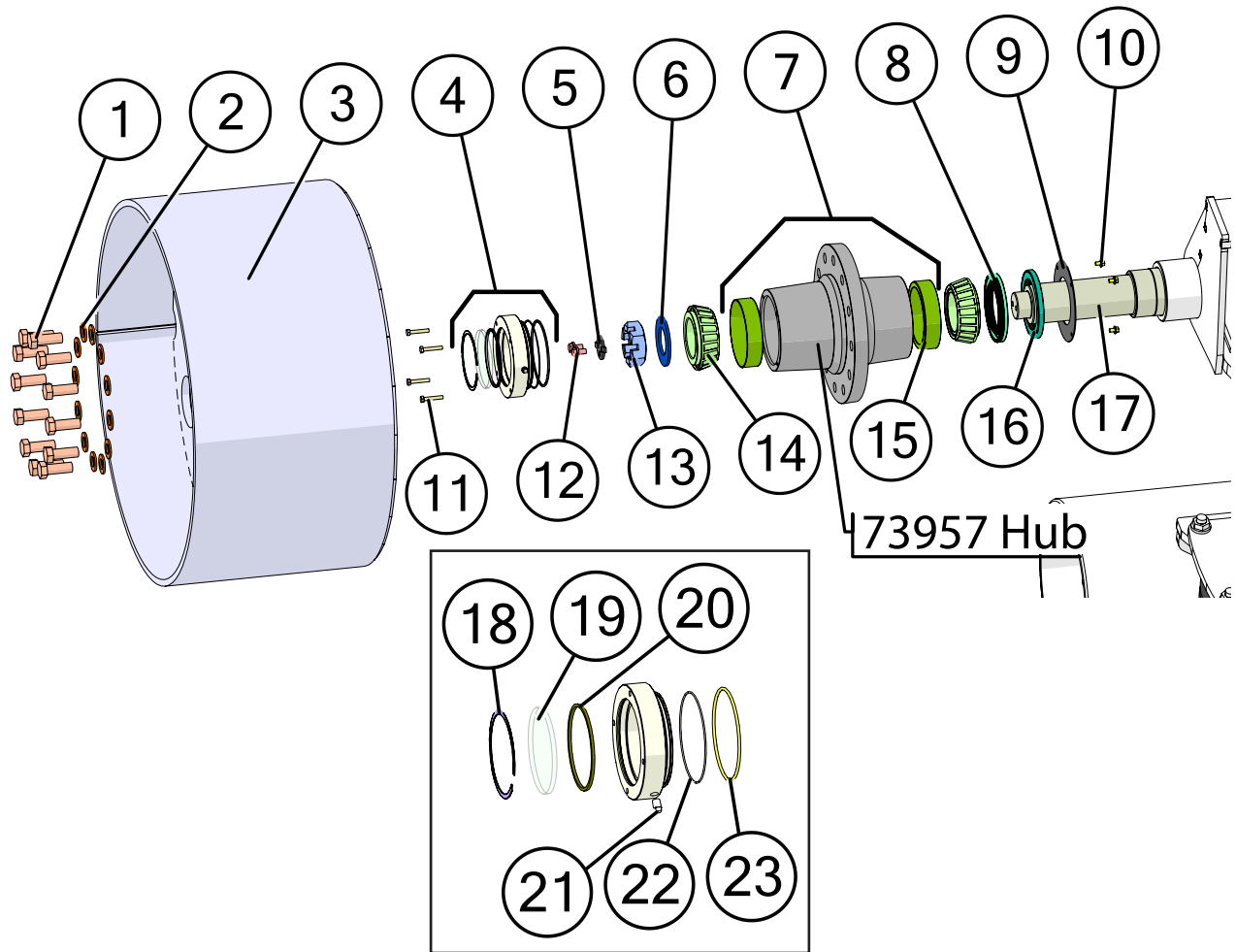

Description	Part No.
1 3/4"-10 x 2" Gr8 YZ Hex Bolt	JM0041923
2 3/4" Hardened YZ SAE Flat Washer	JM0042264
3 46" STX2 - Idler Wheel Weldment 12 Bolt Holes	JM0074305
4 6-1/8" OD Idler Wheel Hub Cap Assembly (46" STX2)	JM0074282
5 2-12 Castle Hex Nut Retainer	JM0054901
6 2-1/8" ID, 3-3/4" OD Flat Washer (3/16")	JM0015900
7 46" STX2 - Idler Hub 12 Bolt Hole and Bearing Cup Assembly	JM0077767
8 3.500 x 5.125 x 0.550 Oil Bath Seal	JM0074294
9 46" STX2 - Idler Wheel Hub - Seal Guard/Retainer	JM0074288
10 1/4"-20 x 3/8" Gr5 Z SF Hex Bolt	JM0060883
11 1/4"-20 x 1-1/2" Gr8 Z Hex Bolt	JM0054649
12 3/8"-16 x 5/8" Gr5 Z SF Hex Bolt	JM0060886
13 2"-12 Gr2 Castle Hex Nut	JM0015899
14 X33215XT-T2 Tapered Roller Bearing Cone	JM0073743
15 Y33215-T2 Tapered Roller Bearing Cup	JM0073742
16 3.500 x 5.125 x 0.438 Oil Seal	JM0074295
17 46" STX2 - Idler Wheel Spindle 3.54" x 38.437"	JM0074281
18 4-3/8" Housing Diameter VH-437-S02 Retaining Ring	JM0054637
19 Hub Cap Sight Window 4.35" Diameter	JM0060881
20 O-Ring Size #243 (4.109ID x 4.387OD x 0.139W) Square Profile	JM0060878
21 1/8"-27 NPT Galvanized Plug (9/32 External Square Head)	JM0061561
22 O-ring Size #049 - 4.989ID x 5.129OD x 0.070W	JM0074287
23 O-ring Size #248 - 4.734ID x 5.012OD x 0.139W	JM0054889



Midroller Hub and Spindle Assembly

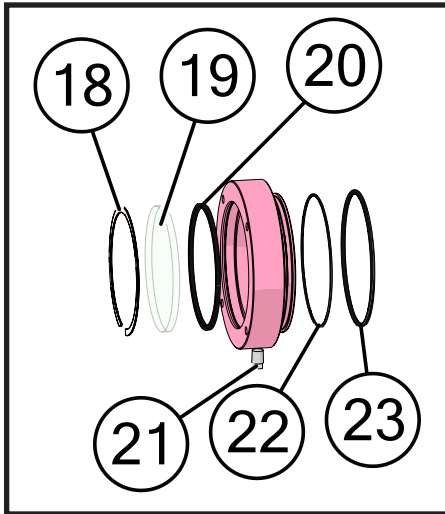
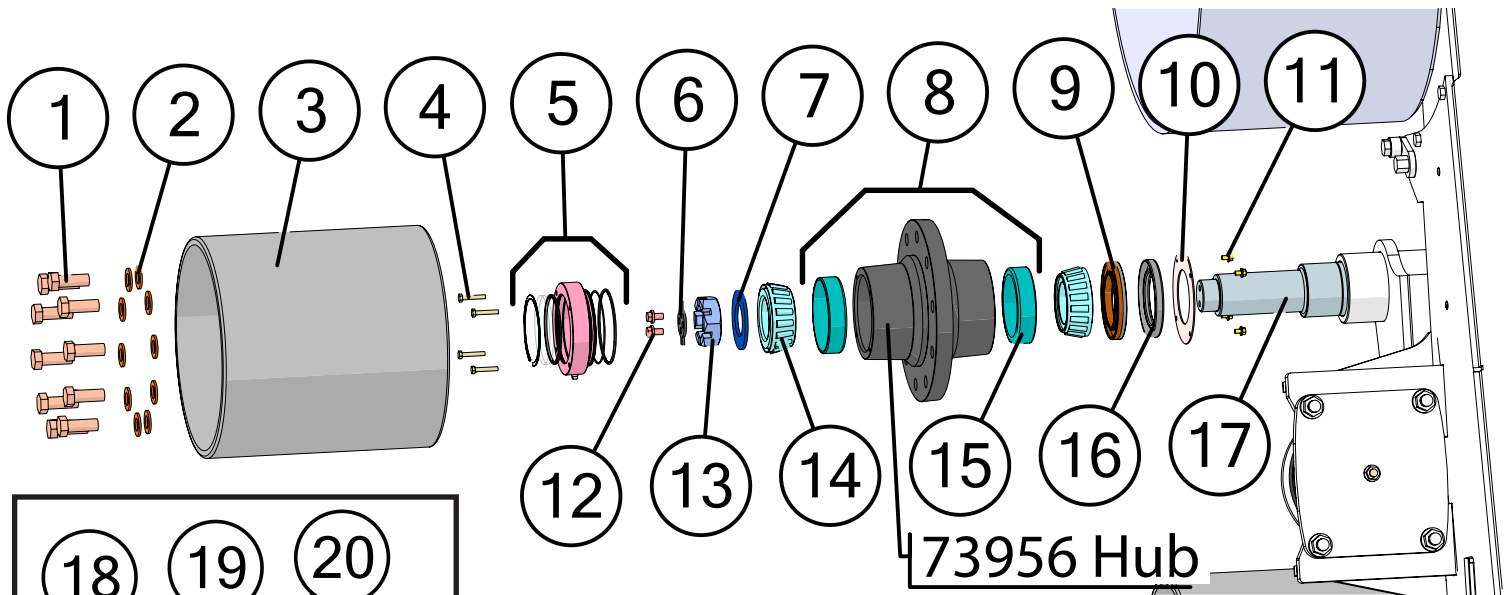

	Description	Part No.
1	3/4"-10 x 2" Gr8 YZ Hex Bolt	JM0041923
2	3/4" Hardened YZ SAE Flat Washer	JM0042264
3	46" STX2 - Bogie Wheel Weldment 10 Bolt Hole	JM0075737
4	1/4"-20 x 1-1/2" Gr8 Z Hex Bolt	JM0054649
5	5-13/16" OD Idler Wheel Hub Cap Assembly (Bolt-On) (36"STX)	JM0061142
6	2-12 Castle Hex Nut Retainer	JM0054901
7	2-1/8" ID, 3-3/4" OD Flat Washer (3/16")	JM0015900
8	73956 Hub 10 Bolt Hole and Bearing Cup Assembly	JM0076655
9	85mm x 125mm x 15.5mm Rotary Shaft Seal	JM0074264
10	5.938" OD Seal Guard/Retainer for Idler Wheel Hub	JM0061133
11	1/4"-20 x 3/8" Gr5 Z SF Hex Bolt	JM0060883
12	3/8"-16 x 5/8" Gr5 Z SF Hex Bolt	JM0060886
13	2"-12 Gr2 Castle Hex Nut	JM0015899
14	Tapered Bearing Cone (HM212049)	JM0018852
15	Tapered Bearing Cup (HM212011)	JM0018854
16	85mm x 125mm x 14mm TC Oil Seal - Type TC	JM0061567
17	46" STX2 - Bogie Wheel Spindle 3-3/8" x 35"	JM0075732
18	4-3/8" Housing Diameter VH-437-S02 Retaining Ring	JM0054637
19	Hub Cap Sight Window 4.35" Diameter	JM0060881
20	O-Ring Size #243 (4.109ID x 4.387OD x 0.139W) Square Profile	JM0060878
21	1/8"-27 NPT Galvanized Plug (9/32 External Square Head)	JM0061561
22	O-Ring Size #047 (4.489ID x 4.629OD x 0.070W)	JM0061144
23	O-Ring Size #246 (4.484ID x 4.762OD x 0.139W)	JM0061143

Tensioner

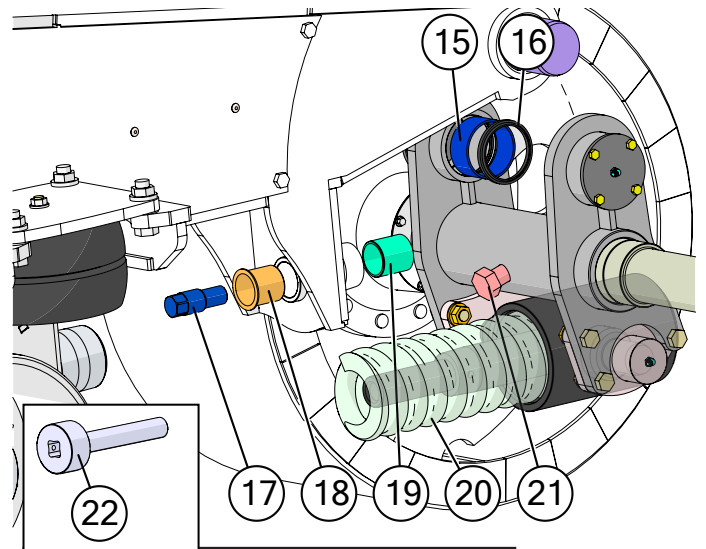
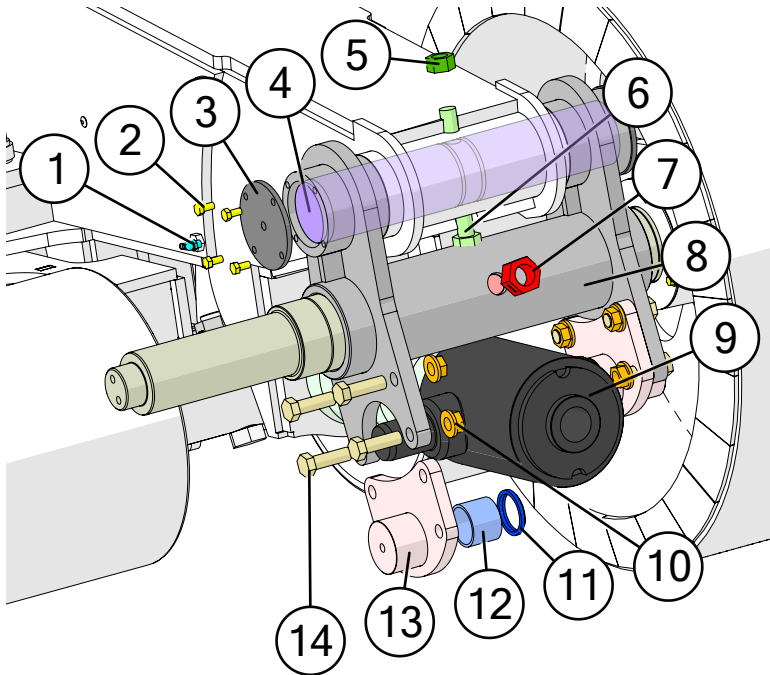

This part is found in your manual canister and is used for tensioning/detensioning the track belt.

Description	Part No.
1 1/8" NPT Male 65 Degree Elbow Grease Fitting	JM0050602
2 5/16"-18 x 5/8" Gr8 YZ Hex Bolt	JM0051107
3 46" STX2 - Tensioner Pivot Spool Cap	JM0075693
4 46" STX2 - Tensioner Pivot Pin	JM0075695
5 3/4"-10 Gr2 Z Centerlock Hex Nut	JM0002147
6 3/4"-10 x 6" Gr5 Z Hex Bolt	JM0016683
7 1"-8 Gr2 Z Centerlock Hex Nut	JM0002149
8 46" STX2 - Tensioner Weldment	JM0075666
9 46" STX2 - Tensioner Spring Pivot Weldment	JM0077093
10 5/8"-11 Gr8 YZ SF Hex Nut	JM0047537
11 1-3/4" ID x 2-1/8" OD Rod Wiper	JM0050512
12 1-3/4" ID x 2" OD x 1-1/2" Sleeve Composite Bushing	JM0030328
13 46" STX2 - Tensioner Lower Side Plate Weldment	JM0077090
14 5/8"-11 x 2" Gr8 Z Hex Bolt	JM0001771
15 3" ID x 3-1/4" OD x 1-1/2" Self-Lubricated Bushing	JM0041920
16 3" Rod Dia. x 3-1/2" Groove Dia. x 1/4" Groove Width Rod Wiper	JM0050254
17 36" STX2 - Tensioner Plunger Nut Plug	JM0061223
18 45mm ID x 50mm OD x 50mm Long Flange Bearing	JM0061541
19 1-3/4" ID x 2" OD x 2" Long Composite Sleeve Bearing	JM0075543
20 5" OD x 19-3/4" Long x 1-1/8" Wire Compression Spring	JM0077098
21 1"-8 x 5-1/2" Gr5 Z Hex Bolt	JM0002110
22 Tensioner Installation Bolt (V4, STX2)	JM0061185

Spring and Midrollers

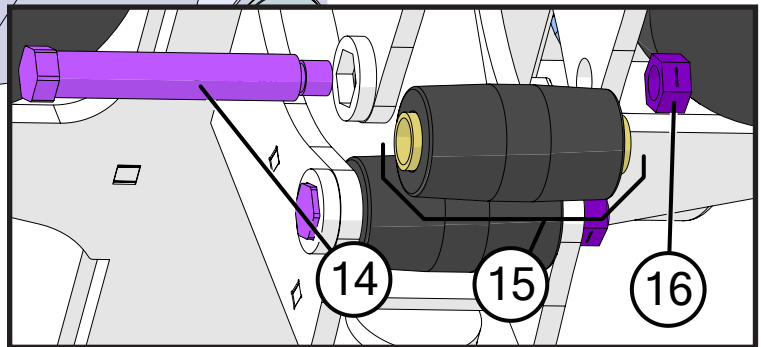
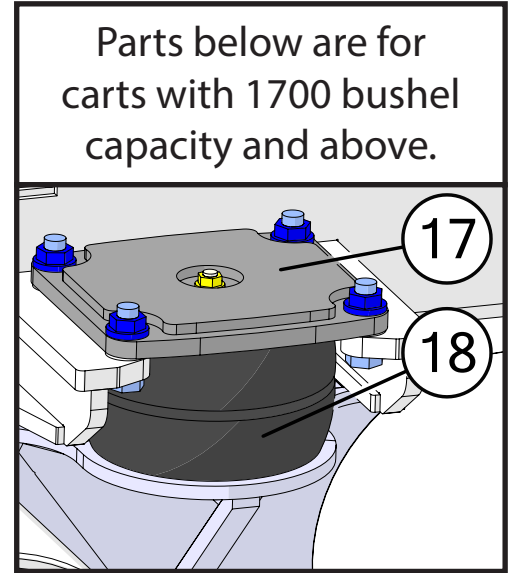
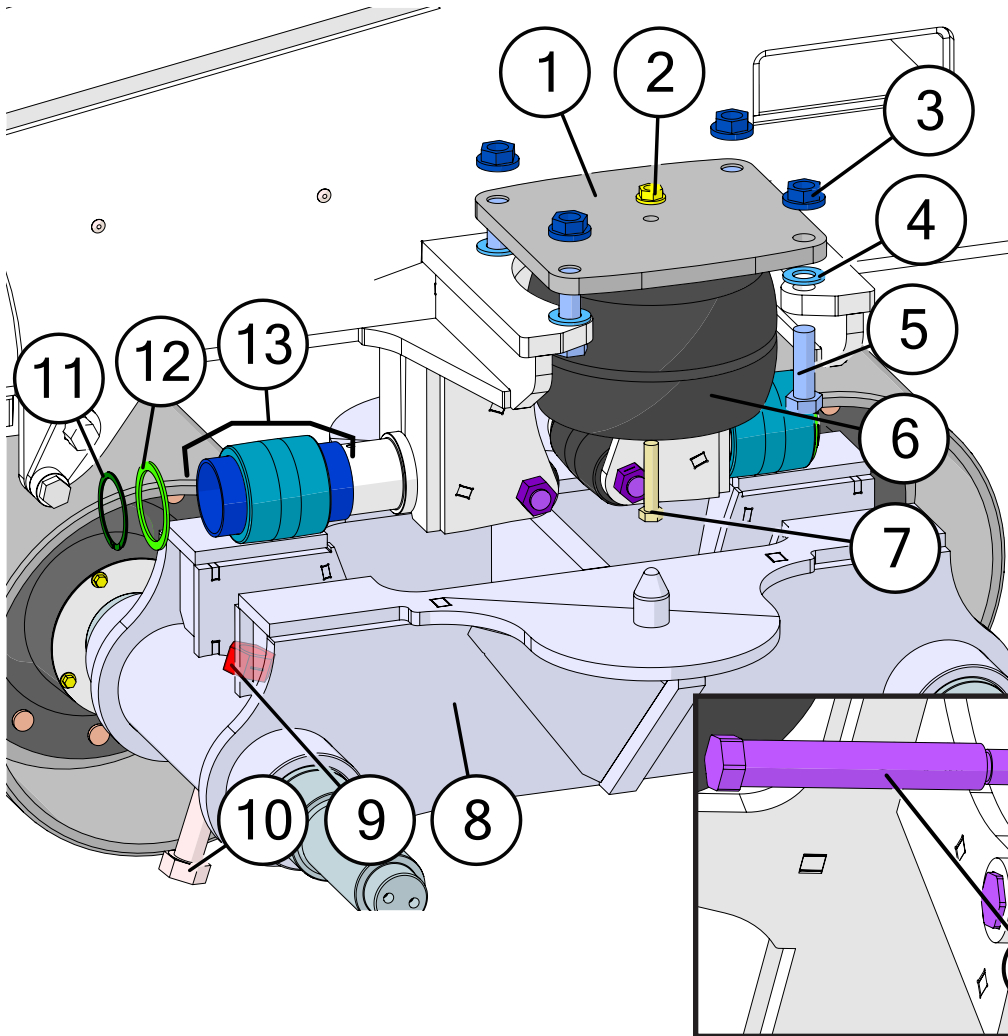

	Description	Part No.
1	Upper Spring Plate for 1500 Bushel Carts and Below	JM0041517
2	1/2"-13 Gr5 Z SF Hex Nut	JM0002153
3	3/4"-10 Gr5 Z SF Hex Nut	JM0009921
4	3/4" Z SAE Flat Washer	JM0043325
5	3/4"-10 x 2-1/2" Gr5 Z Hex Bolt	JM0042591
6	Rubber Spring 6-1/2" OD x 9-1/2" Tall - For 1500 Bu. Cart or Smaller	JM0054557
7	1/2"-13 x 2-1/2" Gr8 Z Hex Bolt	JM0045896
8	46" STX2 - Bogie Frame Weldment	JM0075705
9	1"-8 Gr2 Z Centerlock Hex Nut	JM0002149
10	1"-8 x 5-1/2" Gr5 Z Hex Bolt	JM0002110
11	2-1/2" Shaft Diameter Spirolox WSM-250-S02 Retaining Ring	JM0077393
12	46" STX2 - Longitudinal Guide Roller Washer	JM0077367
13	46" STX2 - Longitudinal Guide Roller Assembly	JM0077366
14	Shoulder Bolt for Transverse Guide Roller (STX-46)	JM0049284
15	Transverse Guide Roller (STX-46)	JM0049375
16	3/4"-10 Gr2 Z Centerlock Hex Nut	JM0002147
17	Upper Spring Plate Weldment for Tracks with 7" Spindle	JM0075684
18	HD Rubber Spring 6-1/2" OD x 9-1/2" Tall - For 1700-2300 Bu. Cart	JM0076433

Hitch

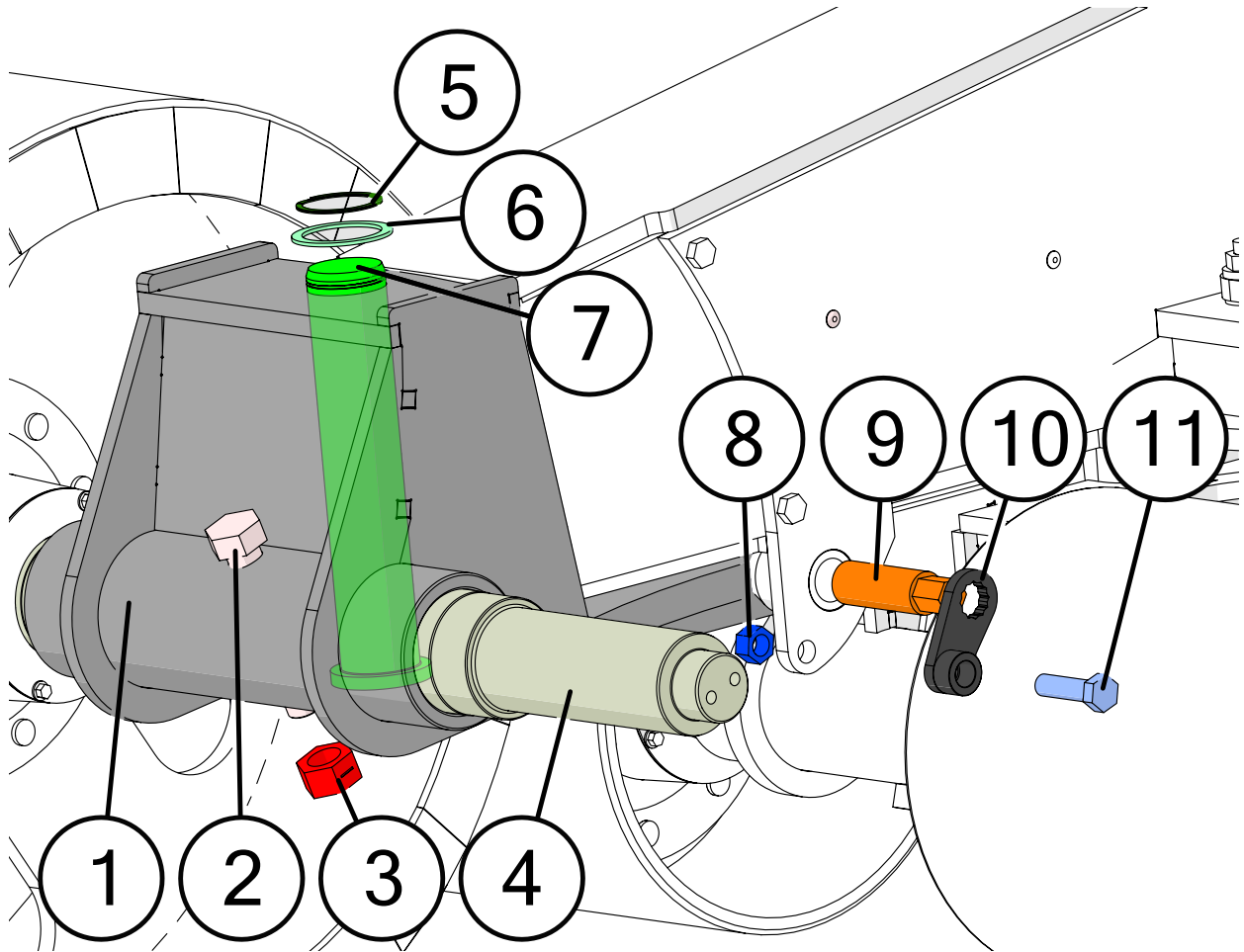

	Description	Part No.
1	46" STX2 - Hitch Weldment	JM0075738
2	1"-8 x 5-1/2" Gr5 Z Hex Bolt	JM0002110
3	1"-8 Gr2 Z Centerlock Hex Nut	JM0002149
4	46" STX2 - Idler Wheel Spindle 3.54" x 38.437"	JM0074281
5	2-1/4" Shaft Diameter Spirolox WSM-225-S02 Retaining Ring	JM0050275
6	Swivel Hitch Pin Washer (3-1/4" OD, 2-9/32" ID, .135" Thick)	JM0042123
7	46" STX2 - Hitch Pin	JM0075773
8	5/8"-11 Gr2 Z Hex Nut	JM0001522
9	46" STX2 - Hitch Alignment Bolt	JM0075770
10	Hitch Alignment Bolt Keeper Weldment (V4, STX2)	JM0050587
11	5/8"-11 x 2-1/4" Gr5 Z Hex Bolt	JM0001493

Upper Rollers

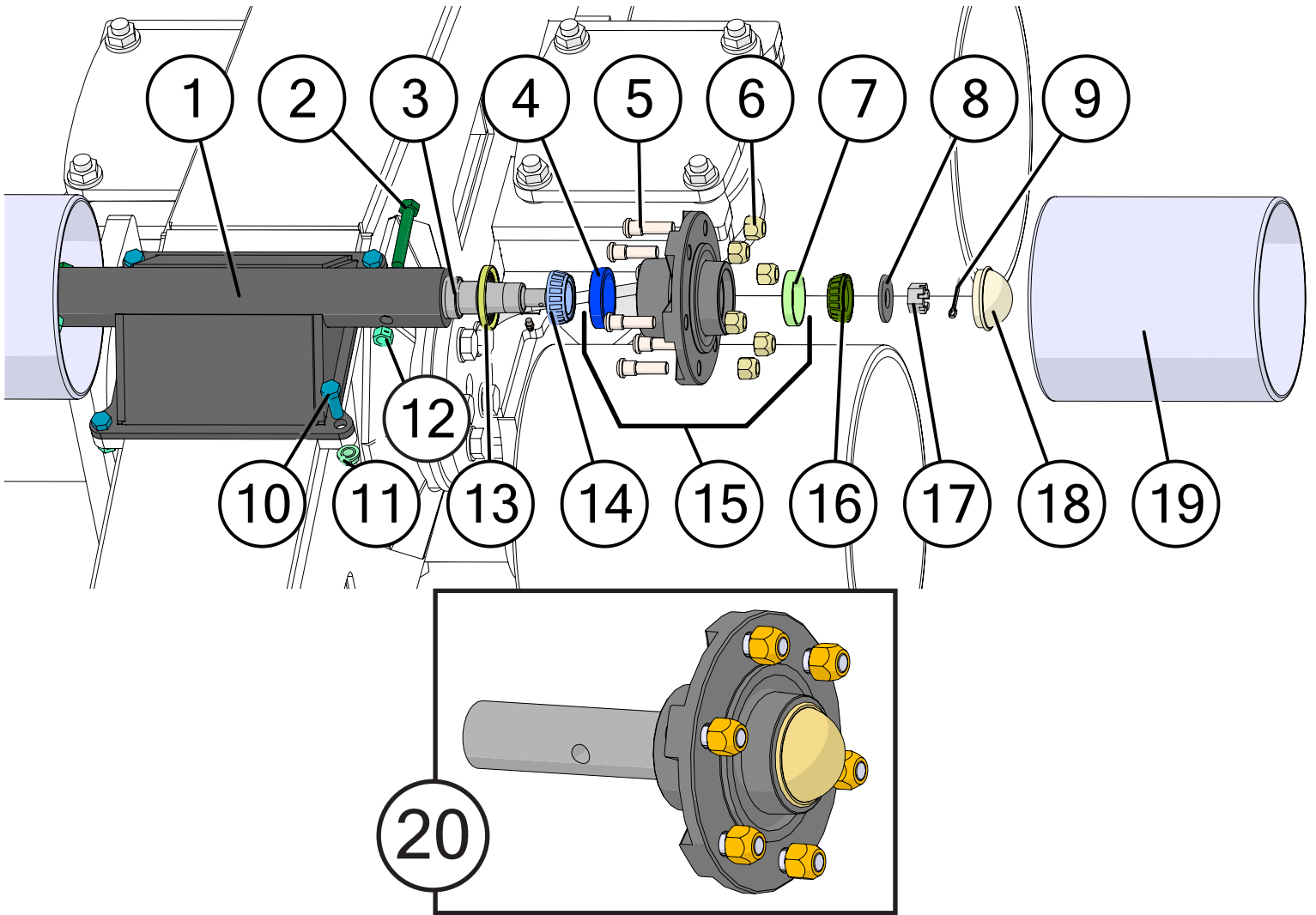

	Description	Part No.
1	46" STX2 - Upper Midroller Bracket Weldment	JM0075673
2	1/2"-13 x 3" Gr5 Z Hex Bolt	JM0016678
3	1-3/4" Diameter Spindle (SS-134SC)	JM0026569
4	Large Cup for 6-8 Ton (LM48510) (104580)	JM0026565
5	Wheel Stud for Hub, 6-8 Ton (1/2"-20 x 1-7/8") (4187)	JM0019559
6	1/2"-20 Lug Nut, 6-8 Ton (5552)	JM0003062
7	Small Cup for 6-10 Ton (LM67010) (200500)	JM0026564
8	3/4" USS Hardened YZ Flat Washer	JM0058394
9	5/32" x 1-1/2" Cotter Pin	JM0014348
10	1/2"-13 x 1-1/2" Gr5 Z Hex Bolt	JM0002100
11	1/2"-13 Gr5 Z SF Hex Nut	JM0002153
12	1/2"-13 Gr2 Z Centerlock Hex Nut	JM0001511
13	Grease Seal, 6-8 Ton (103953)	JM0026572
14	Large Inner Bearing for 6-8 Ton (LM48548) (104579)	JM0019563
15	G25 Hub with Races, Studs and Nuts, 7-8 Ton (105218)	JM0026566
16	Small Outer Cone for 6-10 Ton (LM67048)	JM0019564
17	3/4"-16 Gr2 Castle Hex Nut	JM0002130
18	Dust Cap, 6-10 Ton (103969)	JM0026567
19	46" STX2 - Upper Midroller Wheel Weldment	JM0075697
20	G25-6 Hub, Spindle, and Bearings Assembly	JM0026571

7" Assembly Aid

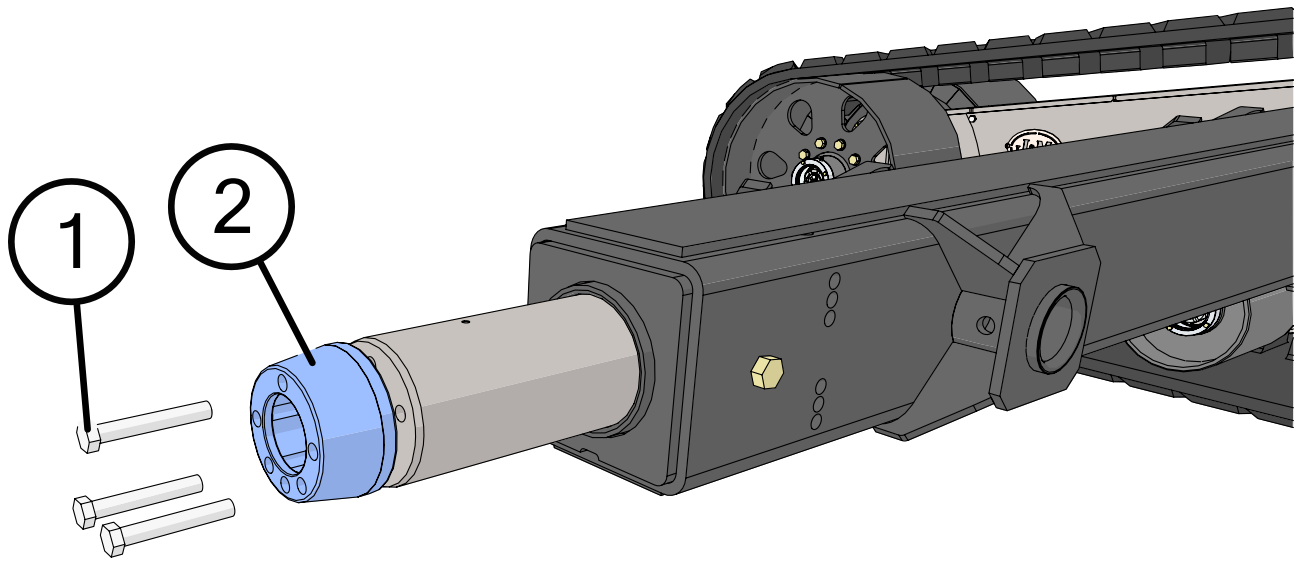

	Description	Part No.
1	3/4"-10 x 5" Gr5 Z Hex Bolt	JM0009997
2	Track-to-Axle Assembly Aid for 7" Center Pivot Spindle	JM0080100

